



# Splash N Dash

**Coleman Hanna Carwash Systems, LLC.  
Houston, Texas USA**

[www.colemanhanna.com](http://www.colemanhanna.com)

# Splash N Dash Start-Up Procedure

Upon receiving the SND system the following procedures must be done.

1. Install the SND system on a level area by bolting down with 4 bolts.



2. Mount the Wand holder for the high-pressure gun to the right side of the SND.

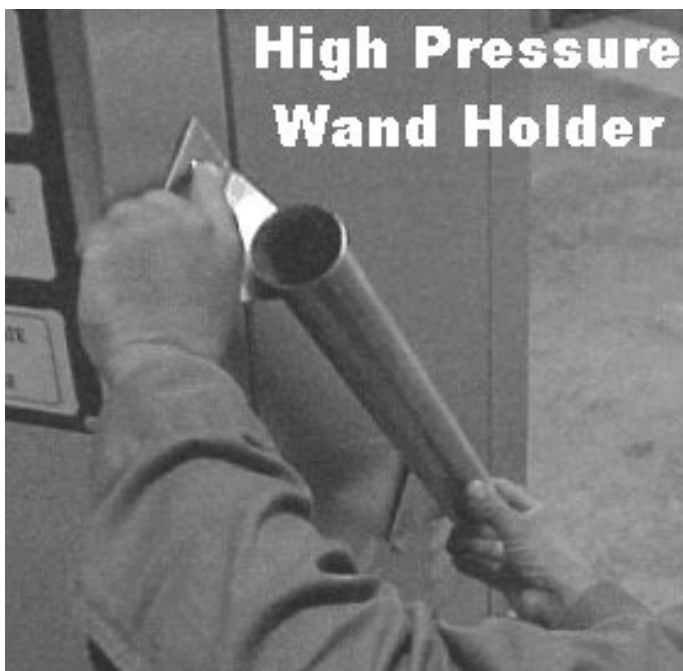

3. Mount the Foam brush holder for the foam brush and handle to the left side of the SND.



4. Connect 220 Volts, 50 cycle, 20-amp service.

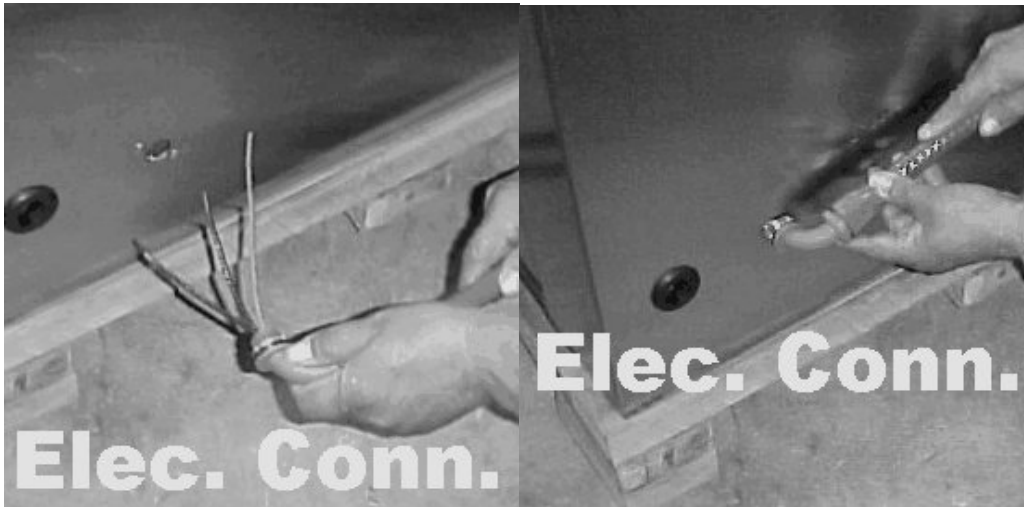

**Caution: Do Not Turn on Power**

5. Connect water line to unit.



6. Turn water on and fill tank.



7. Install the high-pressure hose through the rubber grommet, located on the front of the unit, bottom right-hand side.

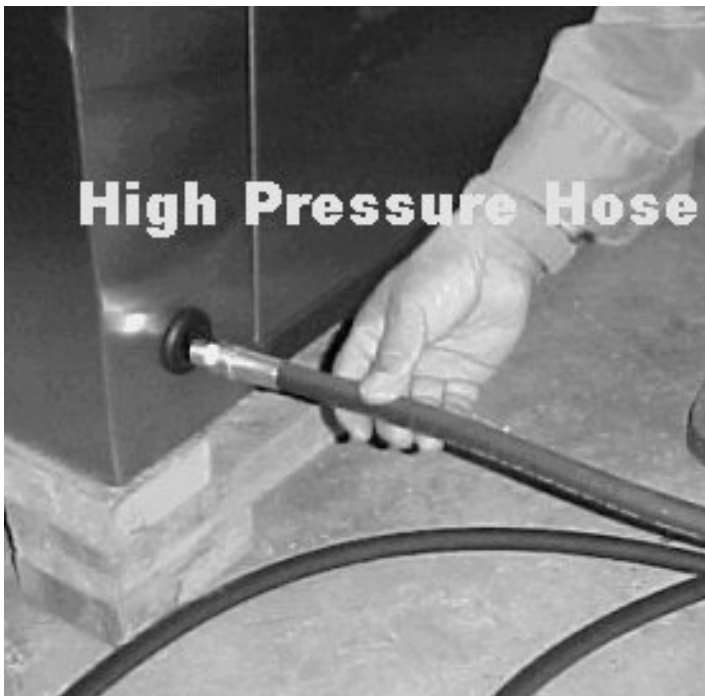

8. Connect to high pressure pump.



9. Connect the trigger gun to the high-pressure hose.

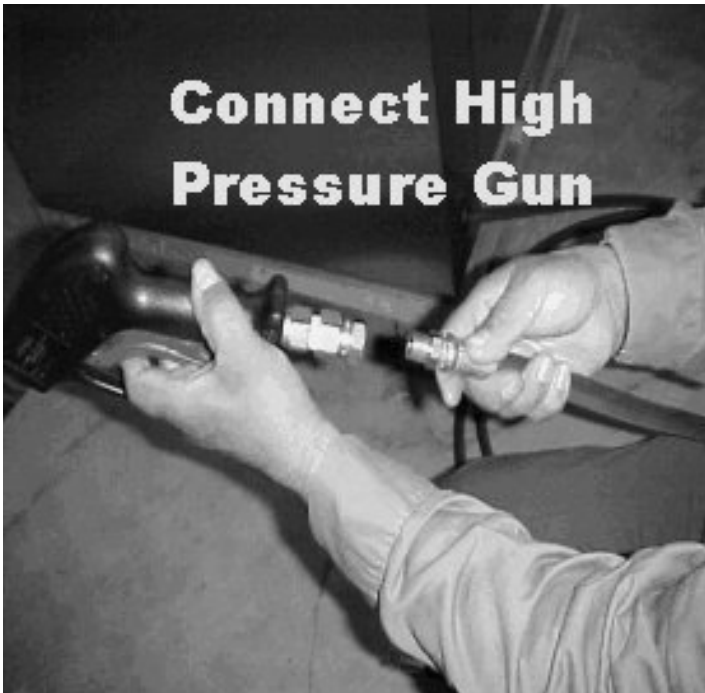

10. Put trigger gun and wand into wand holder.

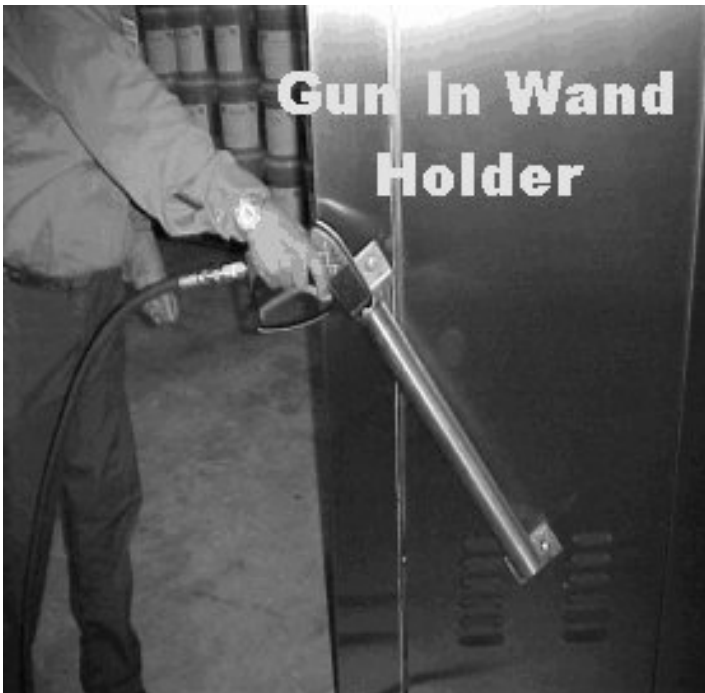

11. Install the foam brush hose through the grommet, located on the front of the unit, bottom left-hand side.

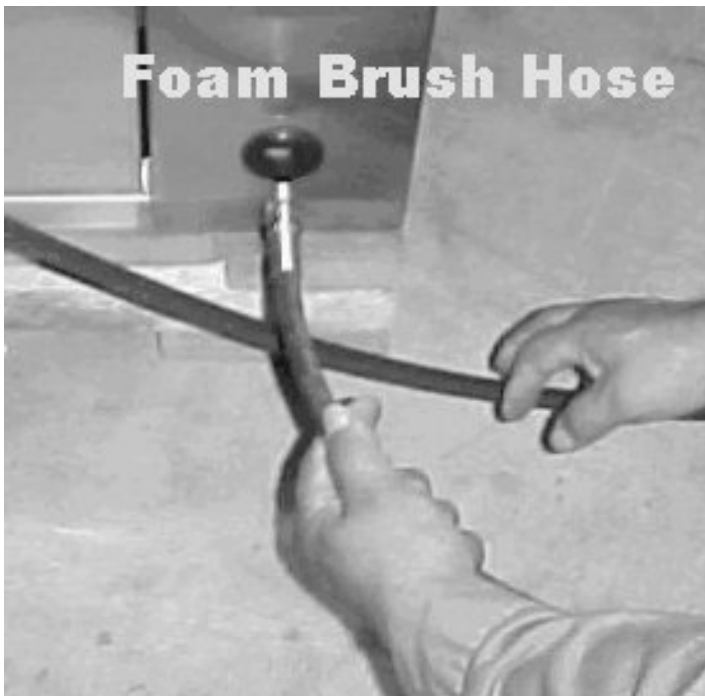

12. Connect to foam generator, located inside cabinet.

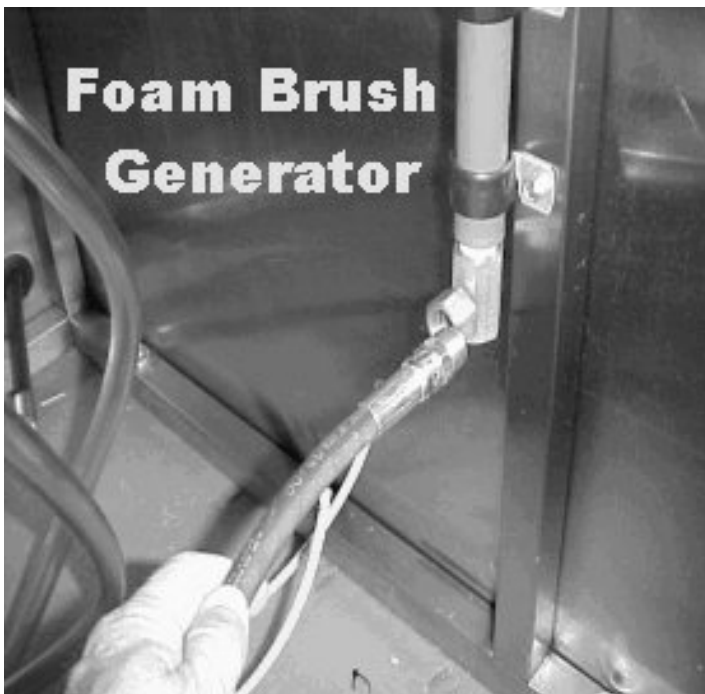

13. Connect foam brush to foam brush handle.



14. Connect foam brush handle to foam brush hose.

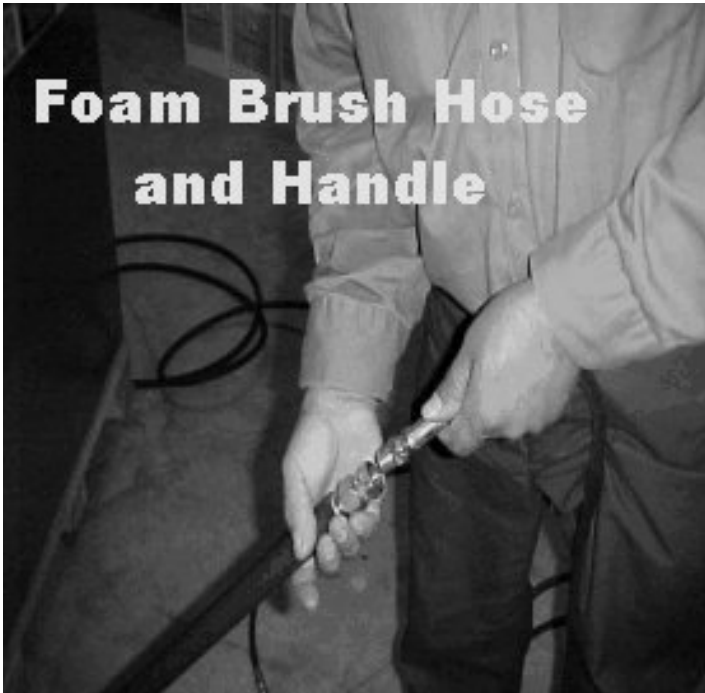



15. Hang the foam brush and handle in the foam brush holder mounted to the left side of the SND.



16. Insert rotary switch through the front of the cabinet.

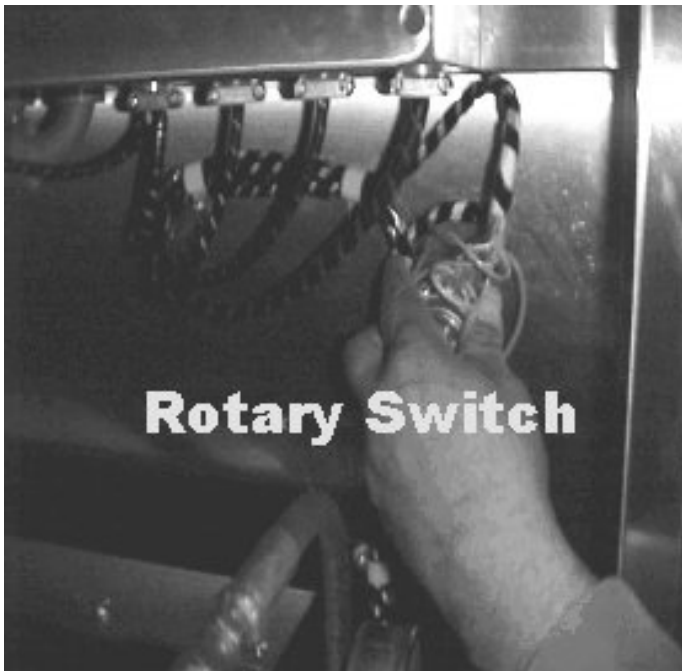

17. Install the Red selection knob.



18. Place chemical suction tube in the concentrated chemical container provided. (4 Req.)

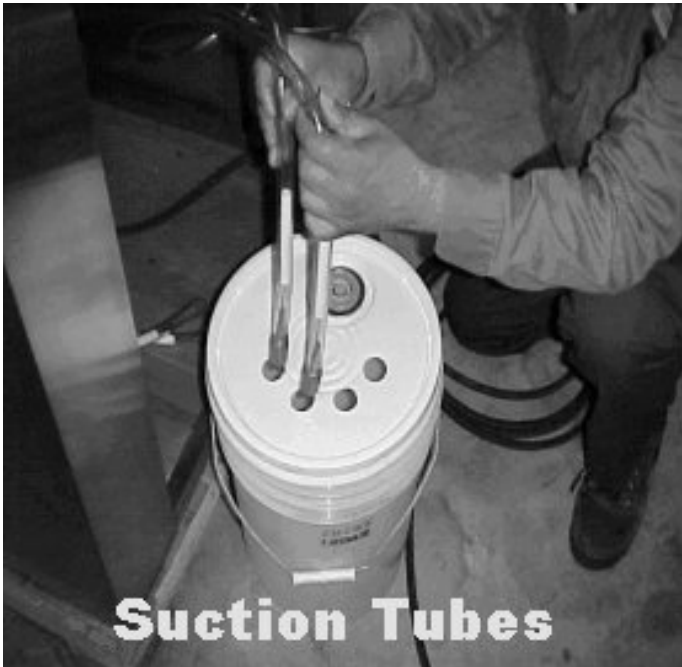

19. Turn the power to unit on.
20. Turn the selection switch to the desired function.



It will take several minutes for chemical to appear.

**TABLE OF CONTENTS**

START- UP PROCEDURES .....2

SEQUENCE OF OPERATION.....3-5

PARTS BREAKDOWN.....6-8

PARTS BREAKDOWN LAY OUT .....9

TROUBLESHOOTING GUIDE.....10-11

SUN SEAL HYPER-CONCENTRAGE CHEMICAL USAGE..... 12

HYDROMINDER TIP USAGE WITH FLO-JET PUMPS ..... 13

DOUBLE TIPS ..... 14

.....

.....

.....

.....

.....

.....

.....

.....

.....

**\*\* READ MATERIAL SAFETY DATA SHEETS  
BEFORE HANDLING PLUMBING CHEMICALS**

**START- UP PROCEDURES**

- 1) Connect 220 volts, 60 cycle, electrical service to the unit. Three- phase power is required on some units. Please check the nameplate for exact requirements. If your unit has a water heater then the total amp draw will be higher. Please refer to the chart below.

	<b>Actual Amp Draw</b>	<b>Breaker Size</b>
3 HP 3 Ø Motor & Pump	9.5	20
3 HP 3 Ø with Water Heater	18	30
5 HP 3 Ø	14	30
5 HP 3 Ø with Water Heater	22	30
3 HP 1 Ø	17	25
3 HP 1 Ø with Water Heater	30	40
5 HP 1 Ø	25	40
5 HP 1 Ø with Water Heater	41	50

**<<< CAUTION >>>**

**DO NOT TURN POWER ON**

- 2) Connect a water line to the unit. Turn the water on, and fill the tank.
- 3) Install the high-pressure hose through the rubber grommet, located in front of the unit, bottom right-hand side. Connect the hose to the pressure pump.
- 4) Install the foam brush hose through the rubber grommet, located on the front of the unit, bottom left-hand side. Connect the hose to the foam generator.
- 5) Insert the rotary switch through the front of the cabinet, and install the selection knob.
- 6) Place the chemical suction tubes into the concentrated chemical containers.
- 7) Turn power to the unit on, and turn the selector knob to the desired function. It will take several minutes for chemical to appear. You will need to prime the low-pressure functions for proper operation.

## **SEQUENCE OF OPERATION**

### High Pressure Soap

- 1) The tank is full of water, and the low-water float switch is in the up position.
- 2) The rotary switch is turned to HIGH PRESSURE SOAP.
- 3) The large motor starter in the control panel is energized, starting the 3 HP motor.
- 4) The soap solenoid is energized, which opens the solenoid, allowing the pump to draw in chemical.
- 5) The water from the stainless-steel tank is drawn into the pump. Along with chemical, and is then pressurized to 900 psi.
- 6) The water/chemical combination is delivered through the safety trigger wand at 900 psi at 3.5 gallons per minute (GPM).

### High Pressure Rinse

- 1) The tank is full of water, and the low-water float switch is in the up position.
- 2) The rotary switch is turned on to HIGH PRESSURE RINSE.
- 3) The large motor starter in the control panel is energized, starting the 3 HP motor.
- 4) The water from the stainless-steel tank is drawn into the pump, and is then pressurized to 900 psi.
- 5) The water is delivered through the safety trigger wand at 900 psi at 3.5 GPM.

### High Pressure Wax

- 1) The tank is full of water, and the low-water float switch is in the up position.
- 2) The rotary switch is turned to HIGH PRESSURE WAX.
- 3) The large motor starter in the control panel is energized, starting the 3 HP motor.
- 4) The wax solenoid is energized, which opens the solenoid, allowing the pump to draw in chemical.
- 5) The water from the stainless-steel tank is drawn into the pump, along with chemical, and is then pressurized to 900 psi.
- 6) The water/chemical combination is delivered through the safety trigger wand at 900 psi at 3.5 GPM.

### Low Pressure Tire & Engine Cleaner

- 1) The tank is full of water, and the low-water float switch is in the up position.
- 2) The rotary switch is turned to TIRE & ENGINE CLEANER. The small yellow relay in the control panel is energized starting up the Flojet pump and tire cleaner solenoid.
- 3) The tire cleaner solenoid allows water to pass into the Flojet pump.
- 4) The Flojet pump draws in water and chemicals into the suction of the pump. The pump will pump the water out the discharge and through a high-pressure check valve, located on the high-pressure pump.
- 5) On the discharge side of the Flojet pump is a small gray plastic primer valve. This valve should remain closed except to prime the pump upon start up.

**<<< IMPORTANT NOTICE >>>**

The Flo-Jet pump is equipped with a primer valve, located on the exhaust of the pump.  
Opening this valve upon start-up of this will allow the chemical to enter the system.  
Once the suction line is clear of air, the valve should be closed for standard operation.

## **SPLASH-N-DASH**

Installation Manual

### Foaming Brush

- 1) The tank is full of water, and the low-water float switch is in the up position.
- 2) The rotary switch is turned to FOAMING BRUSH. The small yellow relay is energized in the control panel starting up the foam brush Flojet pump, air compressor, and foam brush solenoid.
- 3) The small relay in the control panel is energized, starting up the Flo-Jet pump.
- 4) The foam brush solenoid opens up allowing water from the tank to enter the Flojet pump.
- 5) The Flojet pump draws in water and chemical into the suction side of the pump. The pump will pump the water and chemical into the foam generator.
- 6) The mixture then goes to the foam generator, where it is mixed with air from the air compressor, creating foam.
- 7) The foam then travels down the hose, out the brush.

#### **<<< IMPORTANT NOTICE >>>**

The Flo-Jet pump is equipped with a primer valve, located on the exhaust of the pump. Opening this valve upon start-up of this pump will allow the chemical to enter the system. Once the suction line is clear of air, the valve should be closed for standard operation.



PARTS-BREAKDOWN

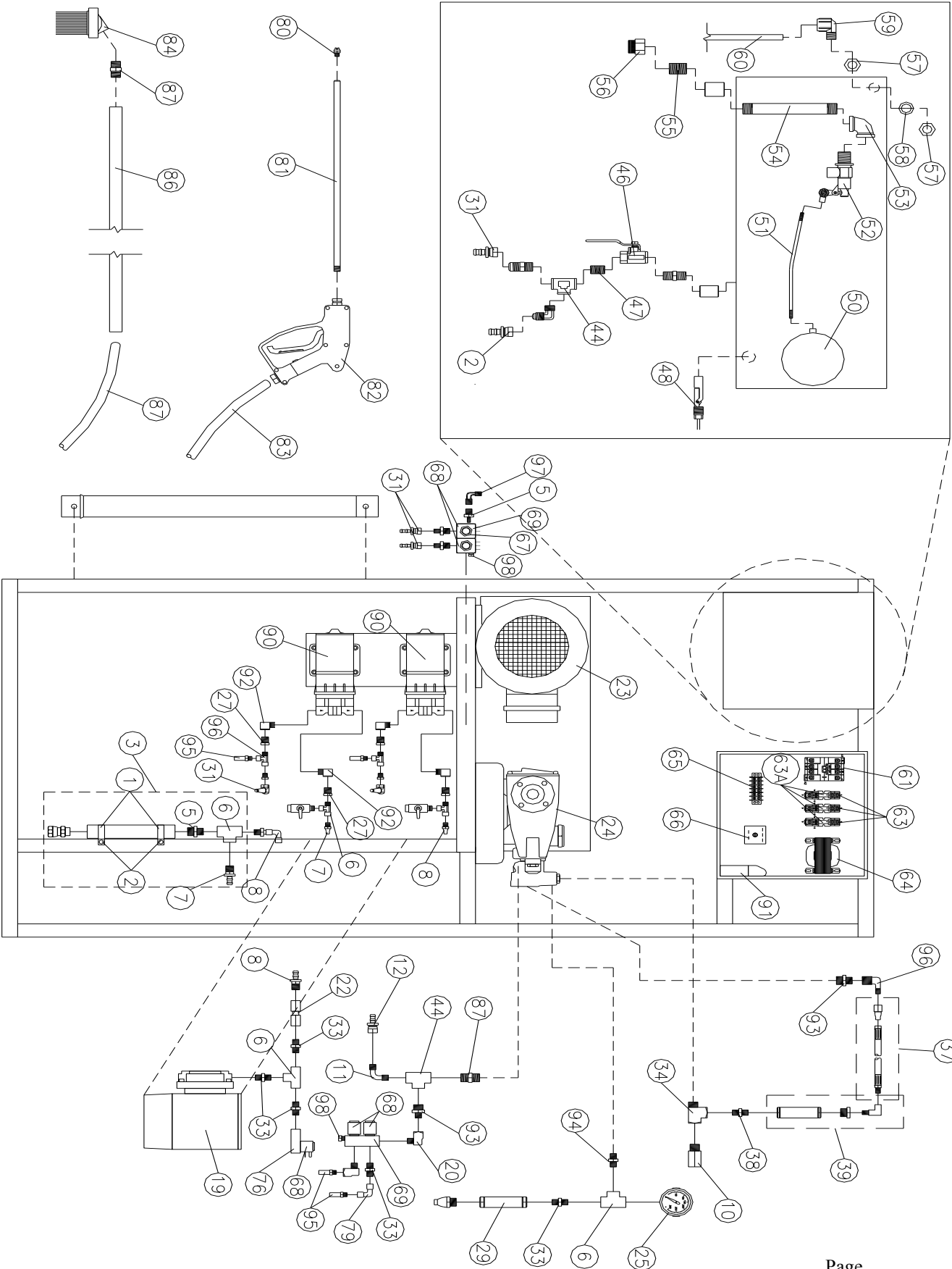

## SPLASH-N-DASH

### Installation Manual

---

1.	Rubber Coated Clamp	22-CL-13
2.	5/16" Self-Tapping Screw	49310
3.	Foam Generator	44820
4.	1/2" NPT x 1/2" Hose Barb	22-30182-8-8B
5.	1/2" NPT x 1/2" Brushing	22-216P-8
6.	1/4" Branch T	22-2203P-4
7.	1/4" NPT x 1/4" Polyflow	22-W68PL-4-4
8.	1/4" NPT x 90° 1/4" Polyflow	22-W169PL-4-4
9.	3/8" SAE Swivel x 3/8" Hose Barb	22-31382-6-6B
10.	3/8" NPT x 3/8" SAE Flare	22-48F-6-6
11.	1/2" NPT x 90° 1/2" SAE Flare	22-149F-8-8
12.	1/2" Swivel x 1/2" Hose Barb	22-30682-8-8B
13.	100 GPH Pro-Con Pump	57002
14.	5/16" x 3/4" Carriage Bolt	49406
15.	5/16" Stainless Steel Flat Washer	49430
16.	5/16" Stainless Steel Hex Nut Nylon Insert	49434
17.	Air Compressor	12005
18.	1/4" Close Nipple	22-215pnl-4
19.	1/4" Inline Low-Pressure Check Valve	34018
20.	3 HP 1 PH or 5 HP 3PH Motor	55261, 55241, 55262, 55243
21.	Cat Pump	32-SCP2120
22.	0-2000 PSI Gauge 1/4" Lower Stem Mount	47020
23.	3/8" x 1/4" Bushing	22-209P-6-4
24.	1/4" x 1" Nipple	22-215PNL-4-15
25.	1/4" High Pressure Check Valve	34000
26.	1/4" Coupling	22-207P-4
27.	1/4" Hex Nipple	22-216P-4
28.	3/8" Branch T	22-222P-4-4
29.	3/8" x 1/8" Bushing	22-209P-6-2
30.	1/4" x 12" Bypass Hose	52001
31.	3/8" Hex Nipple	22-216P-6
32.	Paraplate Regulator	58000
33.	8 Position Rotary Switch	72000

**PARTS BREAKDOWN (con't.)**

34.	Selection Knob	72070
35.	½" Male Pipe Thread x 3/8" Hose Barb	22-30182-8-6B
36.	½" T	22-2203P-8
37.	½" Close Nipple	22-215PN-8
38.	½" 1/4 – Turn Ball Valve	22-V500P-8
39.	½" Hex Nipple	22-216P-8
40.	Low Water Level Shut Off	72050
41.	Stainless Steel Tank	1B003
42.	5" Copper Float	58031
43.	¼" x 12" Brass Rod	58035
44.	¾" Topaz Valve	58001
45.	¾" Brass 90	22-2200P-8-8
46.	¾" x 8" Brass Nipple	22-215PNL-8-80
47.	½" Shoulder Nipple Hex	22-216P-8
48.	½" Ball Valve	22-V500P-8
49.	½" Jam Nut Male Connector	22-48F-8-8
50.	½" Fiber Washer	NOT AVAILABLE
51.	PVC ½" St Ell	22407
52.	PVC ½" Drain Pipe	NO PART #
53.	Motor Starter (Cat Pump)	60056
54.	Motor Starter (Air Compressor & ¼ HP Motor)	CALL FACTORY
55.	Relay Base	40112-17
63a.	SPDT Relay	40112
56.	Transformer – 220V Primary, 24V Secondary	82066
57.	6 Pin Terminal Strip	40010-2
58.	3 Second Timer	60020-3
59.	Nut for Solenoid Coil	64029
60.	24V Coil for Solenoid	64053
61.	2 Stage Solenoid Block	64025
62.	¼" NPT x 45° ¼" FPT	22-2214P-4-4
63.	¼" NPT x 3/8" Hex Nipple	22-216P-6-4
64.	3/8" MPT x 90° ¼" Polyflow	22-W169PL-6-4
65.	3/8" x ¼" Bushing	22-209P-6-4
66.	¼ NPT x 90° ¼" Polyflow	22-W169PL-4-4
67.	Nut for Solenoid Coil	DISCONTINUED
68.	One Stage Solenoid Block	64071
69.	¼" NPT x 90°	
70.	¼" NPT x ¼" Polyflow	22-W169PL-4-4
71.	¼" Branch T	22-2200P-4-4
72.	1/8" NPT 2507 Spray Tip	84104
73.	¼" x 16" Galvanized Wand Tube	84012

**PARTS BREAKDOWN (con't.)**

74.	Trigger Gun (Weep)	84006
75.	¼" x 45' Wire Braid Hose W/F	52393-1
76.	3" x 9" Foam Brush	44006, 44004
77.	½" Hex Nipple	22-216P-8
78.	¾" PVC Foam Brush Handle	44000
79.	½ x 45' Foam Brush Hose	52393-4
80.	Flo-Jet Pump (220 V)	57001
81.	Capacitor for Compressor	DISCONTINUED
82.	Check Valve	34000
83.	3/8" NPT Hex to ¼" NPT	22-216P-6-4
84.	Inductor Tip Holder	48054
85.	¼" Female NPT to ¼" Male Flair 90°	22-149F-4-4
86.	¼" NPT Piped to ¼" Male Flair 90°	22-48F-4-4
87.	¼" NPT Plug	22-218P-4

**TROUBLESHOOTING GUIDE**

<b>TROUBLE</b>	<b>POSSIBLE CAUSE</b>	<b>CORRECTIVE ACTION</b>
Unit will not operate on any function.	Power Source	Check the power to the unit. A tripped breaker or blown fuse may be the cause. Repair as necessary.
	Faulty Transformer	Check for 24V output to the rotary switch. Replace the bad transformer. Check the incoming voltage before replacing.
	Out of Water	Add water.
Unit will not operate on high pressure functions.	Motor	Check the thermal overload of the motor. The motor is possible tripped out.
	Faulty Wiring	Check the connection from the motor starter to the motor.
	Faulty Transformer	Check for 24V output to the rotary switch. Replace the bad transformer. Check the incoming voltage before replacing.
Low pressure chemical output is too watery.  <u>Low Pressure Functions:</u> Tire Cleaner Engine Cleaner Foam Brush	Out of Chemical	Add Chemical.
	Foot Valve Strainer	Clean or replace the strainer.
	Filled with Trash. Flo-Jet	Refer to the Owner's Manual on the Flo-Jet pump.
	Air Compressor	Check the power to the air compressor. If the compressor is running, check that the air flow is sufficient. The air compressor may need to be replaced.

**SPLASH-N-DASH**

Installation Manual

<b>TROUBLE</b>	<b>POSSIBLE CAUSE</b>	<b>CORRECTIVE ACTION</b>
No chemical output on high pressure functions.  <u>High Pressure Functions:</u> Soap Wax	Out of Chemical	Add chemical.
	Foot Valve Strainer Filled with Trash	Clean or replace the strainer.
Pulsating pump or low pressure on high pressure functions.	Seals in Cat Pump	Replace the seals in the Cat pump. Refer to Cat pump owner's manual. Repair as necessary.
	Paraplate Regulator (High Pressure Water Regulator)	Remove the lid of the tank, and clean the strainer.
	Clogged Strainer in Stainless Steel Tank	Remove the lid of the tank, and clean the strainer.
Low pressure on tire cleaner of engine cleaner.	Faulty Flo-Jet Pump	This pump cannot be rebuilt. Replacement is necessary.
	Unit Lost Prime When Chemical Drum Ran Dry	Open primer valve and reprime pump.
Tank overflow.	Faulty Float Valve	Shut off water to the unit. Remove the float valve, and replace.
Leaking swivel.	Faulty Swivel	Replace the swivel.

For Additional Technical Support, Contact:

**COLEMAN HANNA CARWASH SYSTEMS, LLC.**  
**5842 W. 34<sup>TH</sup> STREET**  
**HOUSTON, TEXAS 77092**  
**1.800.999.9878**  
**713.683.9878**

## SUN SEAL HYPER-CONCENTRAGE CHEMICAL USAGE

### High Pressure Applications

950 psi at Pump Gauge  
3.5GPM  
# 7 Spray Tip

#### ***High Pressure Wash***

Chemical: HP75/5 High Pressure Soap  
Product diluted 8:1 before placing in Splash-N-Dash.  
Concentrate Usage: 3/8 oz. per minute w/ pink tip  
Chemical Cost: 5 gal. @ \$121.82, or \$.19 per oz.

#### ***High Pressure Wax***

Chemical: HP73/5 Sun Seal  
Product diluted 8:1 before placing in Splash-N-Dash.  
Concentrate Usage: 1.3 oz. per minute w/ purple tip  
Chemical Cost: 5 gal. @ \$185.30, or \$.29 per oz.  
Amount/Minute: 1.3 oz. per minute, or .04 per minute.  
Cost After Dilution: 5 gal. @ \$20.62, or \$.032 per oz.

### Low Pressure Applications

Flo-Jet Pump  
# 7 Spray Tip

#### ***Low Pressure Tire Cleaner***

Chemical: HP78/5 Whitewall Tire Cleaner  
Chemical Cost: 5 gal. @ \$102.09, or \$.16 per oz.  
Amount/Minute: .55 oz. per minute, or \$.09 per minute.

#### ***Foam Brush System***

Chemical: HP74/5 High Pressure Detergent  
Same product as High Pressure Wash, diluted 8:1.  
Chemical Cost: 5 gal. @ \$121.82, or \$.19 per oz.  
Amount/Minute: 1 oz. per minute, or \$.02 per minute.  
Cost After Dilution: 5 gal. @ \$131.51, or \$.02 per minute.

**HYDROMINDER TIP USAGE WITH FLO-JET PUMPS**

PUMP 2100-689 WITH #1 CAM.

**TIRE CLEANER**

Flow Out of Tip: 40 Oz/Minute

<b><u>Hydrominder Tip</u></b>	<b><u>Chemical Drawn</u></b>	<b><u>Ratio</u></b>
Black	14 oz.	2.8 to
Beige	12 oz.	3.3 to
Red	10 oz.	4 to
White	8 oz.	5 to
Blue	6 oz.	6.6 to
Tan	5 oz.	8 to
Green	4 oz.	10 to
Orange	3 oz.	13.3 to

**FOAM BRUSH**

Flow Out of Brush: 76 Oz/Minute

<b><u>Hydrominder Tip</u></b>	<b><u>Chemical Drawn</u></b>	<b><u>Ratio</u></b>
Orange	7 oz.	11 to
Brown	4 oz.	19 to
Yellow	3 oz.	25 to

It is recommended that the soap be diluted in the drum, 4 to 1, then fed into Flo-Jet Pump with a brown or yellow tip.



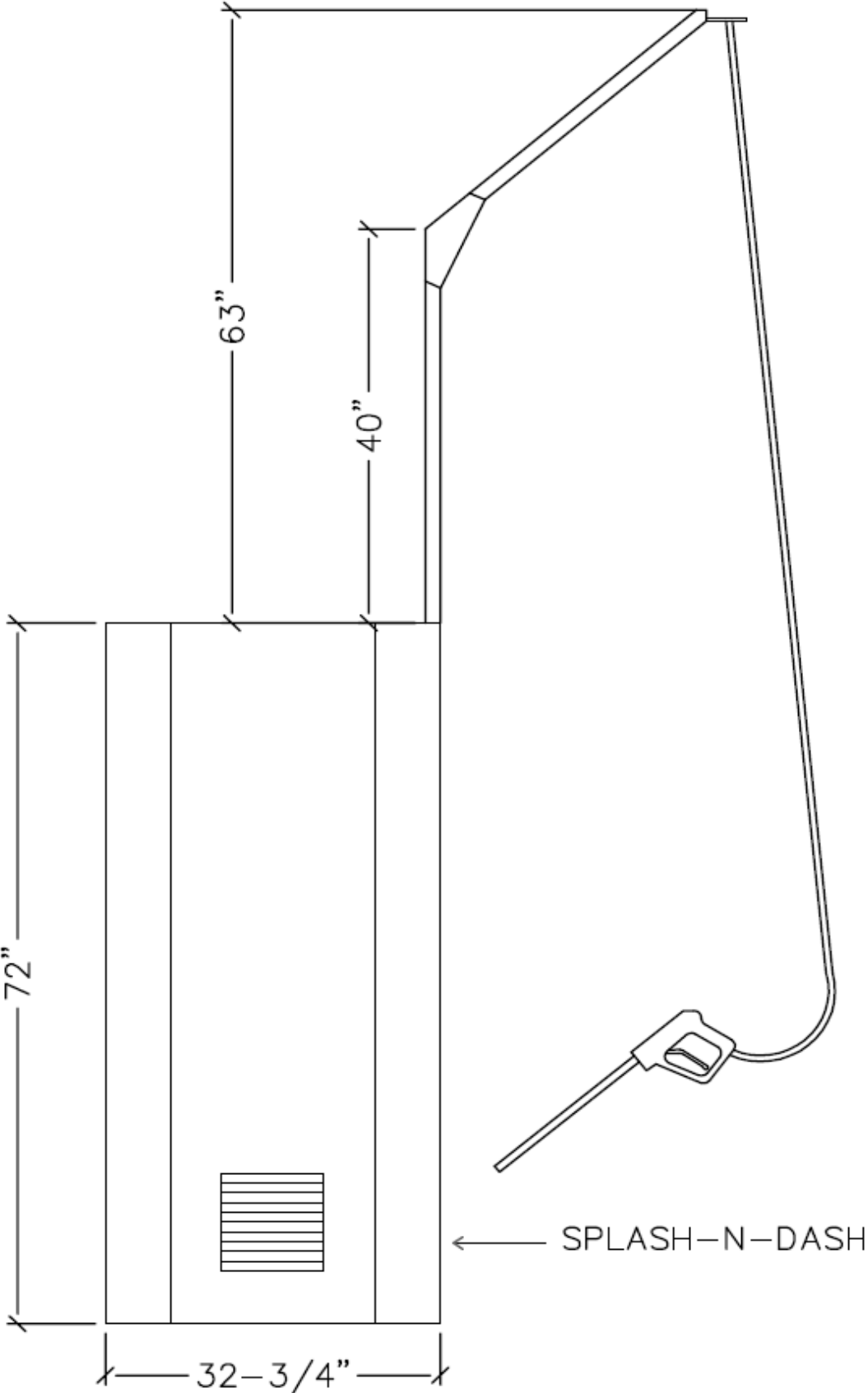

## INSTALLATION INSTRUCTIONS FOR U.S. PARA PLATE BY-PASS REGULATOR

**SIZING** Size your regulator to meet or exceed pump pressure and capacity ratings.

**MOUNTING** The preferred position is vertical, adjusting end up. You can fill the spring area with oil for continuous spring protection. If other than vertical, periodic disassembly to grease the springs is recommended.

**INSTALLATION POSITION** A common position is direct onto the pump manifold. The connecting pipe should be at least the size of the regulator inlet. The discharge connection *must* be at least the size of the valve connection. The discharge (by-pass) line can be pressure type.

**RESTRICTION OF INPUT OR OUTPUT** Flow will greatly reduce performance and could result in premature valve wear.

**DISCHARGE CONNECTION** The discharge hose can be returned to pump input, or to a holding tank. If returned to pump input, protective measures should be taken to avoid recirculation of fluids at high pressures for long periods which can cause excessive temperature buildup in the fluids. The condition can occur if nozzles plug, or if on-off nozzle control spray guns are used. The Para Plate will precisely maintain the desired operating pressure and will prevent spikes during the instant of nozzle plugging, or spray gun shutoff, but cannot prevent the system fluid from heating during recirculation. Back pressure should be avoided. See Back Pressure Table below.

**PRESSURE ADJUSTMENT** The Para Plate is designed for continuous by-pass, and should be used to set and control system pressures. To properly control, a minimum of 10% of rated regulator capacity (minimum 0.5 GPM) must be by-pass at all times. For example, for a 5 GPM rated regulator, 0.5 GPM by-pass will allow effective pressure control.

**WARNING** If your pump output flow in combination with nozzle size sets your pressure, you will not make effective use to the Para Plate. In addition, slight leakage through the Para Plate can cause the pressure to drop slightly below the desired operating pressures. Do not attempt to turn the Para Plate adjusting screw clockwise as an artificially high opening might result if nozzles plug.

You should determine pump output, then select a nozzle which will give you your desired set pressure and still allow a minimum 10% (of regulator rating) by-pass. For example, a No. 8 nozzle and 3.4 GPM combine for a pressure of 700 psi. A No. 7 nozzle requires only 2.9 GPM to develop a 700-psi operating pressure. If your No. 7 nozzle begins to wear and pressure drops, you can raise pressure by turning the adjusting screw on the Para Plate clockwise. New nozzles should immediately be installed. If you adjusted the regulator to compensate for tip wear, new nozzles will cause pressure to go above desired operating pressure. Simply turn the adjusting screw counter-clockwise until you reach desired pressure.

**IMPORTANT NOTE** You should adjust a Para Plate regulator only when the system is on. If on/off controls, such as spray guns, are used at the work or in the bay, leave in closed position. If pressure drops when control is opened, check nozzle size and make certain minimum by-pass requirement is met. In this way you avoid adjusting in artificially high opening pressures. Also, seat damage is avoided when a cushion of water is between piston and seat. You can check the amount of by-pass by disconnecting the output hose and taking a timing on fluid discharging into a measuring container.

**FILTRATION** Any time you want a fluid control device to perform properly with minimum maintenance, some form of periodic system cleanup should take place. Pumps, spray guns, valves, regulators and swivels will work better and last longer if size and amount of contamination is kept to an absolute minimum.

**IS PARA PLATE REGULATOR COMPLEX?** It is more complex because it is truly a regulating valve. It is not designed to be a normally closed pop valve or relief valve. After it is installed properly and fine tuned it will give years of trouble-free service and will provide overall benefits in pressure control and system reliability not available in the conventional valves used for regulating.

FLOW (GPM)	MAXIMUM BACKPRESSURE (PSI)	HOSE I.D. VS. HOSE LENGTH			
		Length (Ft.)	I.D. (in.)	Length (Ft.)	I.D. (in.)
5	50				
10	40	0-8	1/4	0-18	3/8
25	30	0-7	3/8	0-17	1/2
35	20	0-6	1/2	0-16	3/4
		0-5	3/4	0-15	1

For service instructions on Para Plate regulator or other products, consult factory.



### U.S. Para Plate Corporation

12810 Earhart Avenue

Auburn, CA 95602

Telephone: 530.885.8187

Fax: 530.885.8117

Web Site: [www.usparaplate.com](http://www.usparaplate.com)

Email: [usparaplate.com](mailto:usparaplate.com)

SERVICE HINTS

REPAIRING PARAPLATE  
BR5 REGULATORS

Remove by-pass hose from the "L" shaped outlet elbow at the top of the regulator. Remove the regulator from the pump, or "T" or other installation point ; place the bottom cap in a vise and take the regulator shell loose. (You can place the regulator shell in the vise and remove bottom with a 1/8" wrench or an adjustable wrench.) Be careful not to damage the shell. At this time, the piston head along with the stem and spring (washers) will come out. Notice the way the spring is put together. Clean the stem and spring and inspect the washers for a broken one. This seldom happens, but you would repalce as needed. Clean the bottom cap and piston head surface to insure proper seating. The bottom cap is a flat surface and therefore can be lapped flat. The piston head is slightly taoered by design and it is very critical that the taper remain. the seal kit #40027 for all BR Series pressure ranges have four "O"-Rings and the Back-up Ring. A design charge in 1982 caused the use of a thinner "O"-Ring in place of the flatter "O"-Ring at position Number 4. If you have and old valve (prior to '82) Dia. C is approximately 1 3/8" and you use the fatter "O"-Ring Number 5. All new valves are approximately 1 5/16" at Dia C. and use the thinner "O"-Ring Number 4.

- No. 1 is a very small "O"-Ring.
- No. 2 is a split Back-up Ring.
- No. 3 is a "flatter", medium diameter "O"-Ring.
- No. 4 is a "thin", large diameter "O"-Ring.
- No. 5 is a "fatter", large diameter "O" Ring.

Note: If the gun or wand has a loss of pressure but is not leaking, the piston head and the bottom cap may have trash embedded which is causing complete by-pass when the trigger is pulled on.

Materials: Stem, Steel Electroless nickel plated. Piston Head and Bottom Cap, 416 SST hardened. Housing, Brass Electroless nickel plated. Adjustable Screw, Brass Seals, Viton.

By-Pass to pump suction or tank.

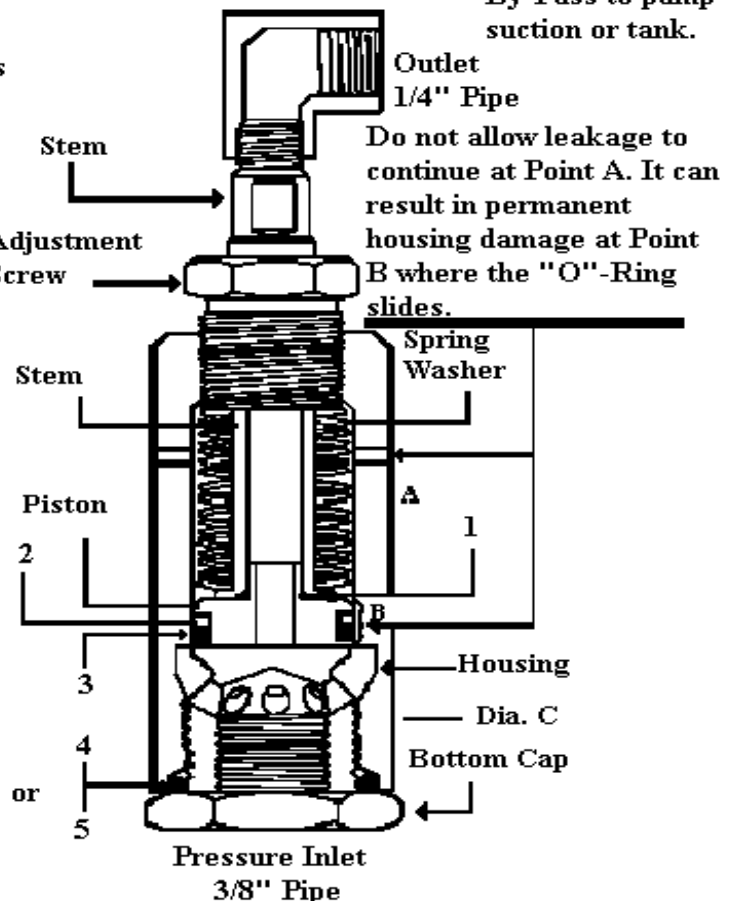

CDT 7/84 FORM 171

# SPLASH-N-DASH

## Installation Manual

