

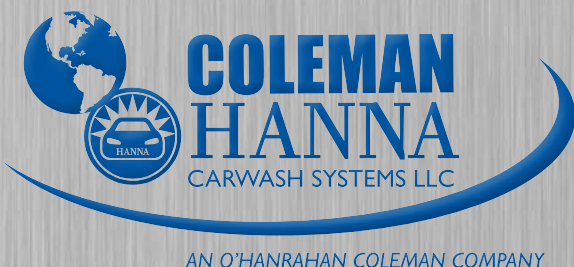

# Tire Washers

## *Service Manual*



5842 W 34th St, Houston, TX 77092  
1.800.999.9878 • 1.713.683.9878  
[www.colemanhanna.com](http://www.colemanhanna.com)



Find us on Facebook:  
[/ColemanHannaCarwash](https://www.facebook.com/ColemanHannaCarwash)

# Table of Contents

- 1.0 INTRODUCTION.....1-1**
  - 1.1 Design Features.....1-2
    - 1.1.1 Bar Linkage.....1-2
    - 1.1.2 PVC Guides .....1-2
    - 1.1.3 Brush Assemblby .....1-2
    - 1.1.4 Motor Cover .....1-3
    - 1.1.5 Hydraulic Motor .....1-3
    - 1.1.6 Arm Bearings .....1-3
    - 1.1.7 Pneumatic Cylinder Assemblies .....1-4
    - 1.1.8 Bumper Stops .....1-4
  - 1.2 Basic Operation.....1-4
  
- 2.0 SAFETY .....2-1**
  - 2.1 Cautions, Warnings, and Notes .....2-2
  
- 3.0 INSTALLATION .....3-1**
  - 3.1 Performance Requirements .....3-1
  - 3.2 General Requirements.....3-2
  - 3.3 Setup.....3-2
  - 3.4 Structure Installation .....3-3
    - 3.4.1 Modifying the Guid Rail.....3-3
    - 3.4.2 Centering and Mounting the Structure.....3-5
    - 3.4.3 Height Adjustment.....3-9
  - 3.5 Pneumatic Connections .....3-11
  - 3.6 Hydraulic Connections .....3-14
  - 3.7 Startup.....3-16
    - 3.7.1 Standard Mode.....3-16
    - 3.7.2 On-Demand Mode.....3-16
  - 3.8 Installation Check List .....3-17
  - 3.9 Hanna Hydraulic Tubing Color Code .....3-18
  
- 4.0 PARTS AND MAINTENANCE.....4-1**
  - 4.1 General Maintenance.....4-1
    - 4.1.1 Daily Maintenance.....4-1
    - 4.1.2 Weekly Maintenance.....4-1
    - 4.1.3 Monthly Maintenance.....4-1
  - 4.2 Lubrication.....4-2
  - 4.3 Catalog of Replacement Parts .....4-3

## Table of Figures

Figure 1-1	Hanna Tire Washer Without Motor Covers .....	1-1
Figure 1-2	Bar Linkages .....	1-2
Figure 1-3	PVC Guides.....	1-2
Figure 1-4	Brush Assemblby .....	1-2
Figure 1-5	Motor Covers.....	1-3
Figure 1-6	Hydraulic Motor .....	1-3
Figure 1-7	Bearing .....	1-3
Figure 1-8	Installed Air Cylinder .....	1-4
Figure 1-9	Mounted Bumper Stop .....	1-4
Figure 3-1	Isometric View of the Tire Washer .....	3-1
Figure 3-2	Orientation of the Hanna Tire Washer.....	3-3
Figure 3-3	Angled Modification to the Guide Rail .....	3-4
Figure 3-4	Extend Postion of the Conveyor Side of the Tire Washer .....	3-4
Figure 3-5	Brush Bar Parallel to Conveyor .....	3-5
Figure 3-6	Rotary Hammer .....	3-5
Figure 3-7	Anchor Bolt.....	3-5
Figure 3-8	Base Plate Positioning .....	3-6
Figure 3-9	Mounted Tire Washer with Dims .....	3-7
Figure 3-10	Tire Washer Extended and Retracted with Dims .....	3-8
Figure 3-11	Side View with Brush Rotation .....	3-9
Figure 3-12	Brush Clearance From Ground .....	3-9
Figure 3-13	Brush Clearance From Ground .....	3-9
Figure 3-14	Brush Clearance From Ground .....	3-10
Figure 3-15	Brush Clearance From Ground .....	3-10
Figure 3-16	Pneumatic Cylinder Assemblby.....	3-11
Figure 3-17	Air Connections for Pneumatic Board .....	3-11
Figure 3-18	Pneumatic Flow Adjustment.....	3-12
Figure 3-19	Pneumatic Board Diagram .....	3-13
Figure 3-20	Hydraulic Flow.....	3-14
Figure 3-21	Triple-Loc Fitting.....	3-14
Figure 3-22	Priority Valve Adjustment .....	3-15
Figure 3-23	Hydraulic Color Coding .....	3-18
Figure 4-1	Bearings .....	4-2

## 1.0 Introduction

The Hanna Tire Washer utilizes a number of Hanna's developed technologies to make this component the most effective, rugged and fast cleaning system in the car washing market. As one of Hanna's best selling components, the Tire Washer is made of high quality stainless steel and has been rigorously tested in the field to assure the highest quality standards are met.

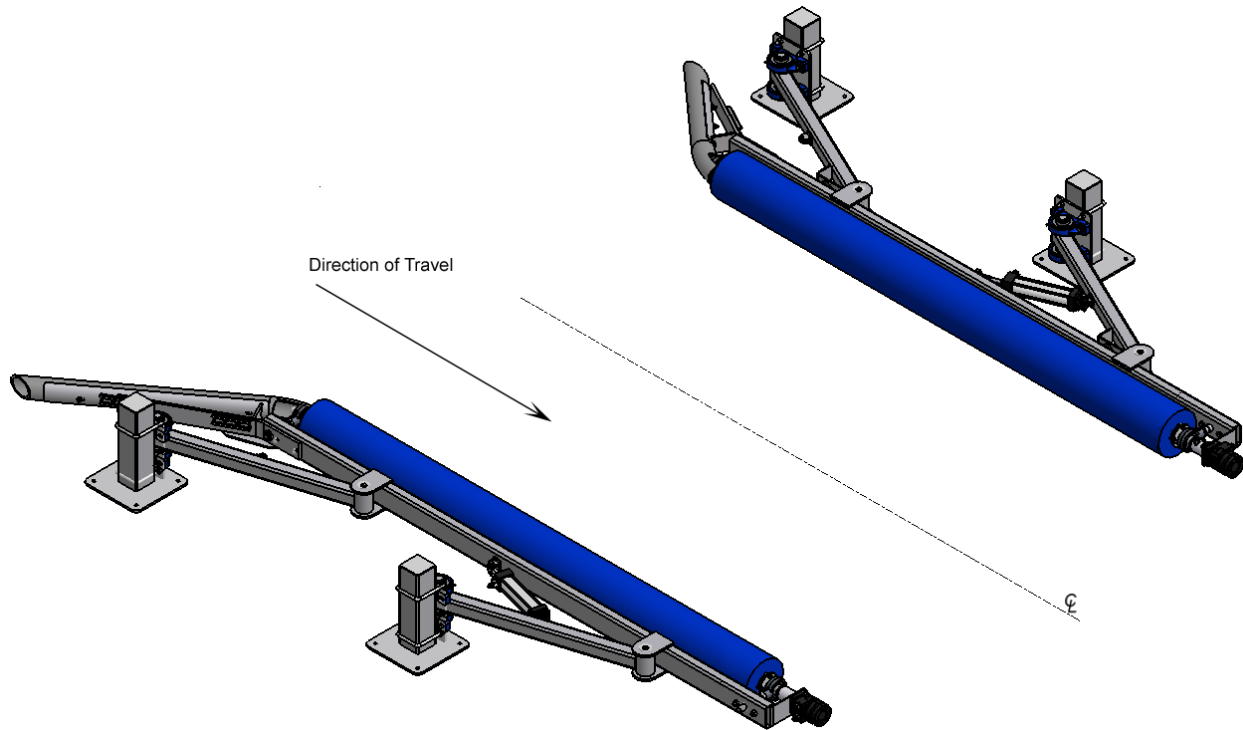

**Figure 1-1. Hanna Tire Washer (without motor covers)**

## 1.1 Design Features

### 1.1.1 Bar Linkage

Built of stainless steel, the bar linkages maintain perfect parallel alignment of the brushes for even pressure delivered to the tires.



Figure 1-2. *Bar Linkages*

### 1.1.2 PVC Guides

The custom fit guide rails for the Tire Washer quickly and safely positions the tires and withstands harsh impacts under carwash tunnel conditions.



Figure 1-3. *PVC Guides*

### 1.1.3 Brush Assembly

The flanged 96" X 8" diameter brush configuration simplifies changing for easy maintenance and replacement.



Figure 1-4. *Tire Washer Brush Assembly*

### 1.1.4 Motor Cover

Built of stainless steel and the same durable material used for Hannatron guide rail, the motor covers provide excellent protection from deterioration through exposure of chemical and water.

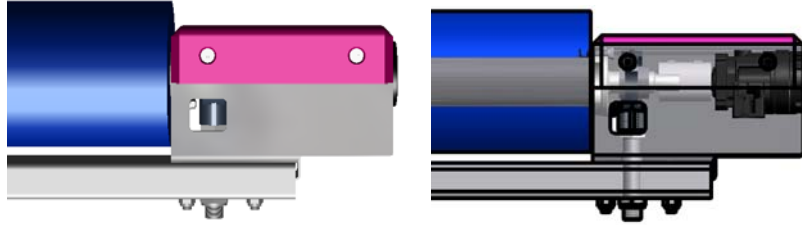

Figure 1-5. Motor Cover show as installed (right) and in see-through (left)

### 1.1.5 Hydraulic Motor

The two durable black-coated motors utilize a hydraulic unit used to rotate the brushes at a revolution of 200 RPM. Requirements are 4.3 GPM and a pressure of 400 PSI of hydraulic fluid.

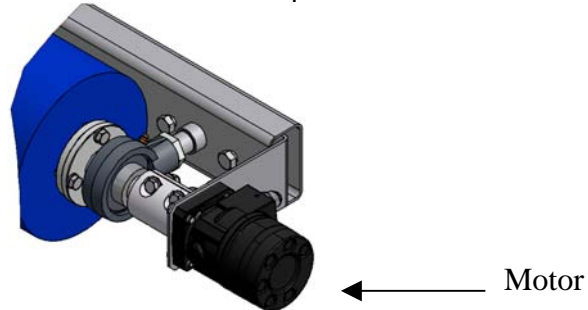

Figure 1-6. Hydraulic Motor

### 1.1.6 Arm Bearings

The heavy-duty arm bearings are the best available on the commercial market. Designed to allow angular alignment for the brush arm and painted for maximum corrosion resistance.



Figure 1-7. Post Bearing

### 1.1.7 Pneumatic Cylinder Assemblies

The pneumatic cylinder assemblies control the retractable arms on the Tire Washer. While providing even distribution of pressure, the automobile tires will always have a quality wash without the worry of missed, or lightly cleaned areas of the tire.



Figure 1-8. *Installed Cylinder Assembly*

### 1.1.8 Bumper Stops

The Bumper Stops provide a cushioned stop on both the extend and retract position



Figure 1-9. *Mounted Bumper Stop*

## 1.2 Basic Operation

A hydraulic motor is directly coupled to the brush shaft and provides the necessary torque to rotate the brush against the tires. The hydraulic motors receive hydraulic fluid from the proportionator and will continue to rotate the brush as long as the system hydraulic power package is operating. As the Tire meets the PVC guide, the brush assembly starts to open to the width necessary to receive the tire, as the tire rolls along the brush length, it is continuously scrubbed until the tire exits the brush. The 96" brush length will effectively scrub the circumference of the passenger car tires varying from 13 – 17 inch wheels. Please contact your Hanna distributor about our chemical applicator option for the Tire Washer.

## 2.0 Safety

Keep the following safety rules in mind when installing and using the Hanna Tire Washer:

**NOTE:** *Always follow local and national trade codes when installing any equipment.*

- Always disconnect power from any electrical device or component prior to servicing.
- Unplug the unit or use proper lock-out procedures so that no one can inadvertently turn the power on while you are working on that equipment.
- Always power down the control box before unplugging or plugging in quick disconnects.
- Use caution when maintaining any piece of equipment.
- Wear protective clothing and eyewear when using power tools.
- Direct discharge of high-pressure water and chemicals away from you and other persons, or direct it into approved containers.
- Keep equipment clean for proper operation.
- Keep hands or any body parts away from equipment while in operation.
- If you need to disassemble a part for service or repair, re-assemble equipment according to instructions.
- Be sure all components are firmly screwed or latched into position.
- Observe safety and handling instructions of the chemical manufacturers.
- Wear protective clothing and eyewear when dispensing or working with chemicals or other potentially hazardous materials.



## 2.1 Cautions, Warnings, and Notes

Throughout this manual, there are various messages concerning safety – please heed these warnings! The following sections give some examples of these safety messages.

### 2.1.1 Cautions

Cautions warn against a potential hazard that, if not avoided, may result in minor or moderate injury. Caution signs also alert against unsafe practices that may cause property damage.



**CAUTION:**

### 2.1.2 Warnings

Warning messages warn against a potential hazard that, if not avoided, may result in serious injury or death.



**WARNING:**

### 2.1.3 Notes

Note means reader take note. Notes contain helpful suggestions.

**NOTE:** *This parameter should NOT be changed when attempting to make system adjustments.*

## 3.0 Installation

The following information is a recommended means for installation of the Hanna Tire Washer. Check for the local utilities, hydraulic supply, and spatial requirements. If anything must be changed, do so prior to the day of installation. Deficiencies discovered at the time of installation will greatly increase time spent before startup.

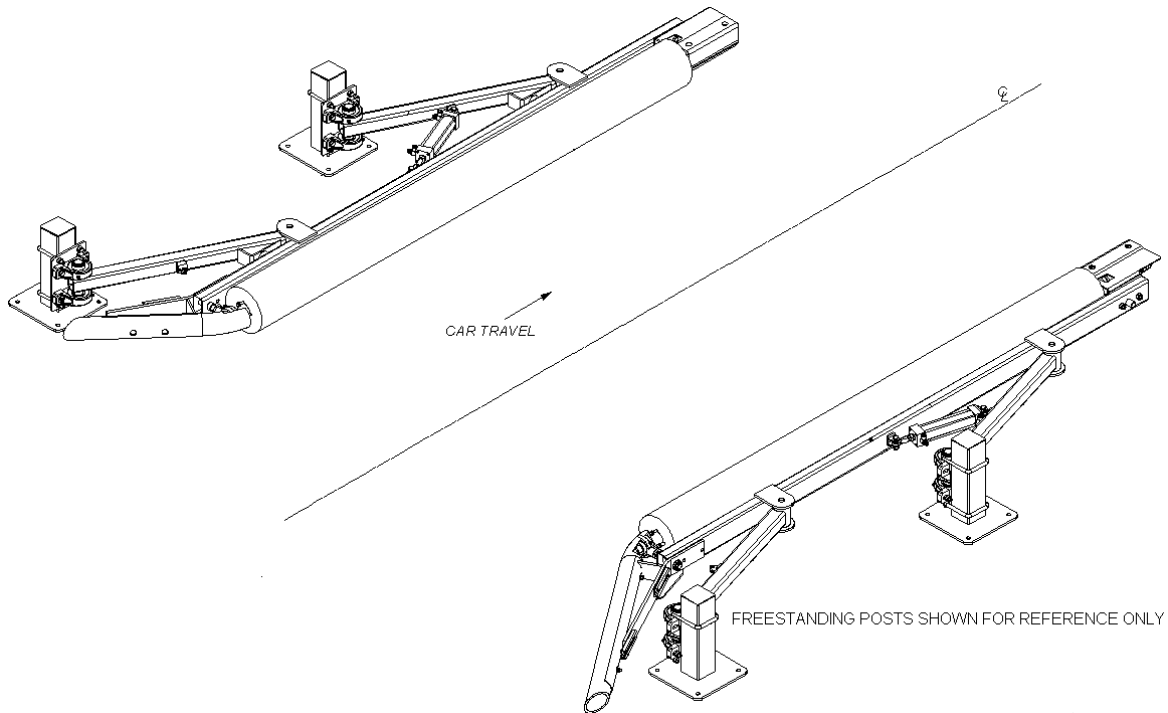

Figure 3-1. Isometric Layout of the Hanna Tire Washer

## 3.1 Performance Requirements

- Water: None
- Solution Required: None
- Hydraulic: 4.3 GPM @ 200 PSI
- Motor Rotation Speed: 200 RPM
- Air Required: .02 SCFM per car
- Electrical: 15 Watts @ 24 VAC
- Dimensions: Please refer to the layout drawing provided with this manual
- Functions: 1 for the hydraulic solenoid, 1 for the retract

## 3.2 General Requirements

Before getting started, you must find the proper location for your Hanna Tire Washer. Refer to the M1 Equipment Layout drawing or Tire Washer technical drawing included in this manual for correct placement and spatial dimensioning.

## 3.3 Setup

1. Read this manual prior to opening crates or installing equipment.
2. Carefully open crates and identify the individual parts for assembly using the enclosed checklist. If there are any missing parts, notify your Hanna distributor immediately.



**WARNING: WHEN USING A FORKLIFT TO INSTALL EQUIPMENT MAKE SURE TO FOLLOW OSHA AND GENERAL SAFETY RULES AND REGULATIONS TO ENSURE PERSONAL SAFETY.**

3. Place the Tire Washer in the wash bay as shown on the layout drawing (available if purchased with system). Make sure the framework is facing the correct direction for vehicle travel. When all pieces for your configuration have been set in place, take the time to recheck the packing lists.
4. Make sure all of the necessary tools are on-hand before work is begun.
  - ✓ Set of ratchets/wrenches to secure bolts, nuts, connections, anchors, etc
  - ✓ A rotary hammer to drill holes for the anchor bolts
  - ✓ Large hammer to insert the anchor bolts to the floor
  - ✓ A power grinder to remove excess material from the anchor bolts
  - ✓ Tube cutters for poly connections
  - ✓ Blade/box cutter
  - ✓ Level tool to assure that the tire brushes are level
  - ✓ Tape measure to acquire proper distances and identifying marks
  - ✓ Teflon tape for fittings
  - ✓ Anti-seize for stainless steel hardware attachment
  - ✓ Forklifts for heavy material

### 3.6 Tire Washer Installation

5. Once the Tire Washer has been placed in its designated section of the tunnel, make sure that the assembly is oriented correctly before it is mounted. Correct orientation can be identified by the front PVC bumpers are at the entrance and the hydraulic motors are at the exit.

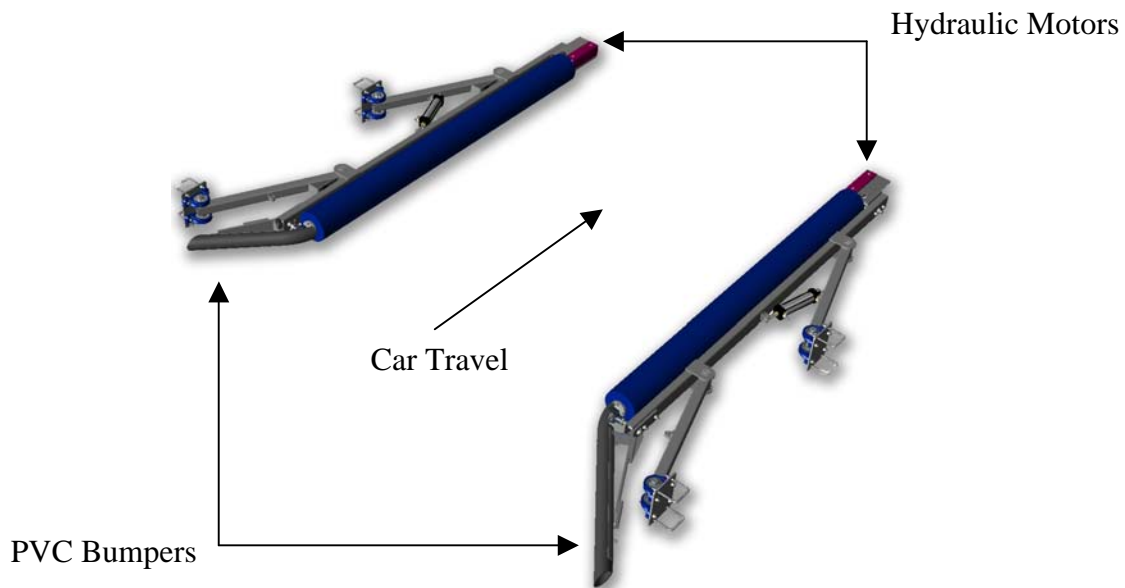

Figure 3-2. Orientation of the Hanna Tire Washer

#### 3.4.1 Modifying the Guide Rail

6. Once the conveyor side brush position has been established, make a cutout in the outside guide rail as shown in figure 3-4.
7. Layout 127" rail to be cut.
8. First remove 3" x 3" UHMW Hannatron and cut completely through the 5" channel
9. Next cut the area where the channel is attached to the support brackets. Cut these and grind off any sharp edges to prevent tire damage.
10. On the exit end of the cut area, measure 20" along the guide rail.
11. Scribe a line 6" toward entrance of the car wash; scribe a second line  $\frac{1}{2}$ " toward the exit of the car wash

12. Burn a segment from top and bottom flange of channel only, leaving web of channel intact.
13. Bend the guide rail to  $2\frac{1}{4}$ " as shown in the figure 3-3.
14. After cutting and bending the outside guide rail, grind and round off the edges. Pay special attention that the exit end motor area is ahead of the bent portion of the guide when brush is in operating position.
15. Weld a support for the end of the bent section under the channel.

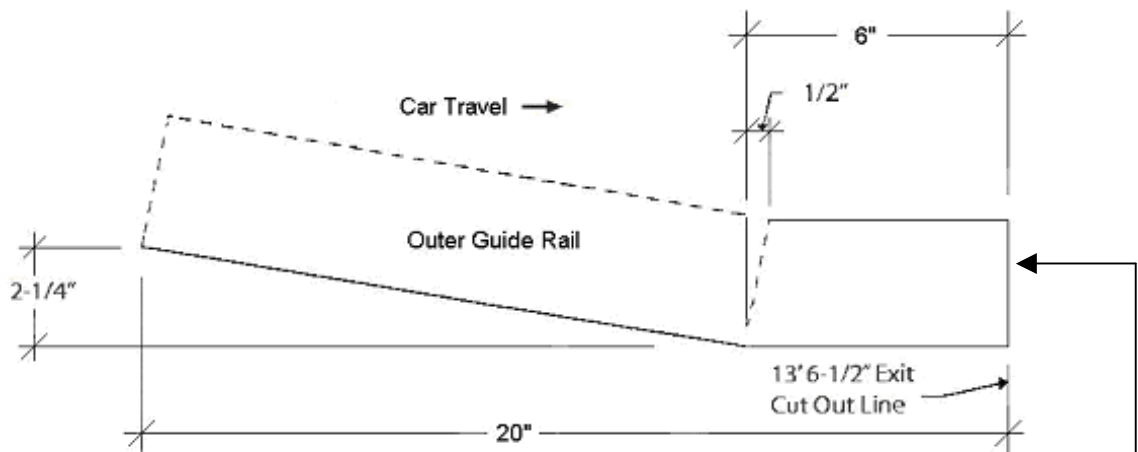

Figure 3-3. Angled Modification to the Guide Rail

16. If the conveyor is cut out correctly it will resemble the diagram below.

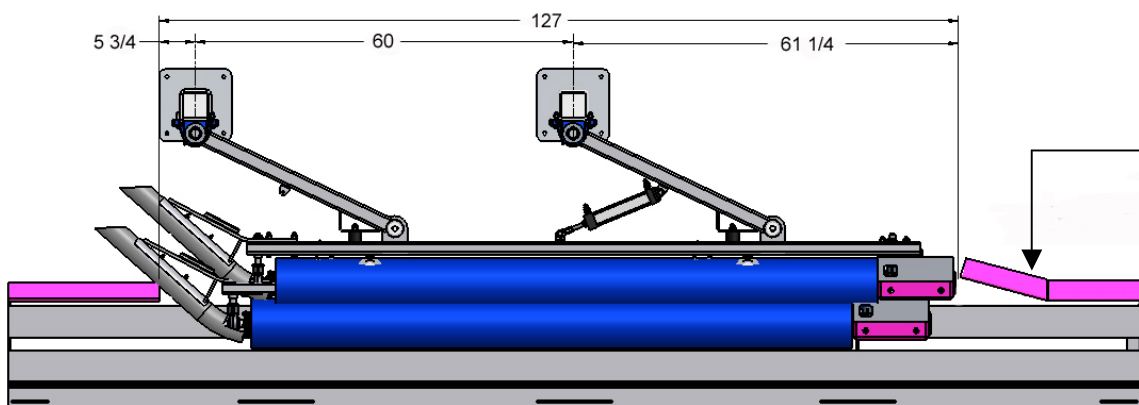

Figure 3-4. Extend Position of the Conveyor Side of the Tire Washer

### 3.4.2 Centering and Mounting the Structure

17. Move the conveyor side brush into final position and correctly align prior to anchoring down
18. Use the brush bar rather than the tire washer base plate to align the unit parallel to the conveyor.

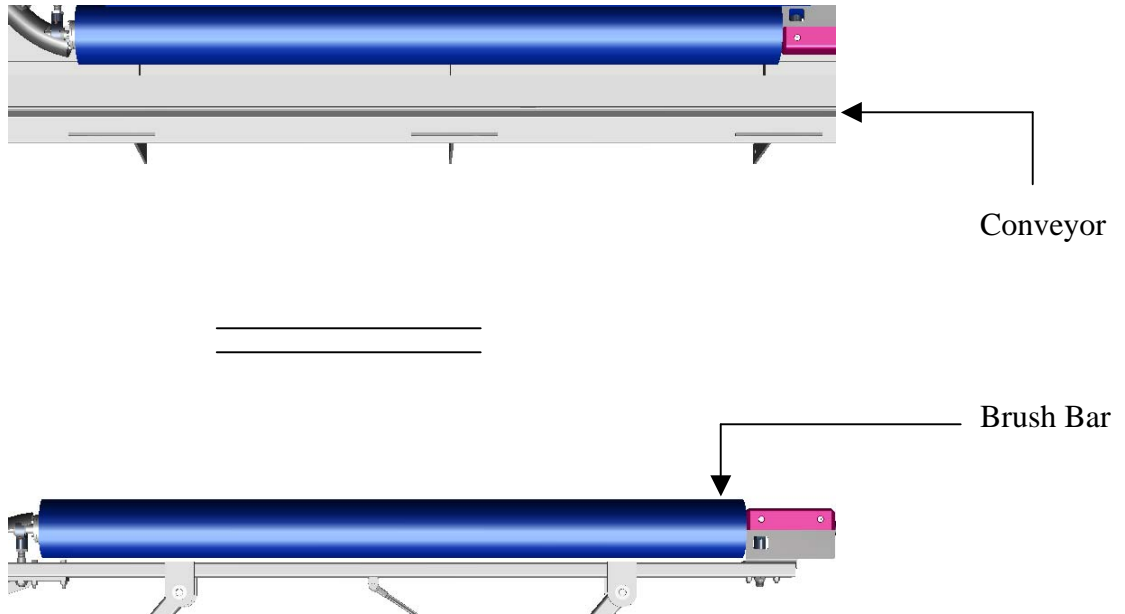

Figure 3-5. *Brush Bar Parallel to the Conveyor*

19. Mark the conveyor side base plates and us the rotary hammer to drill (8) holes suitable for 1/2" X 5" anchor bolts.



Figure 3-6. *Rotary Hammer*

20. Drive expansion bolts into the ground



Figure 3-7. *Anchor Bolt*

21. Double check for accuracy before anchoring the base plates. If centered correctly, there will be **76 3/4 inches** from the outer edge of each base plate to the centerline. Refer to the drawings and/or M1 Equipment layout to

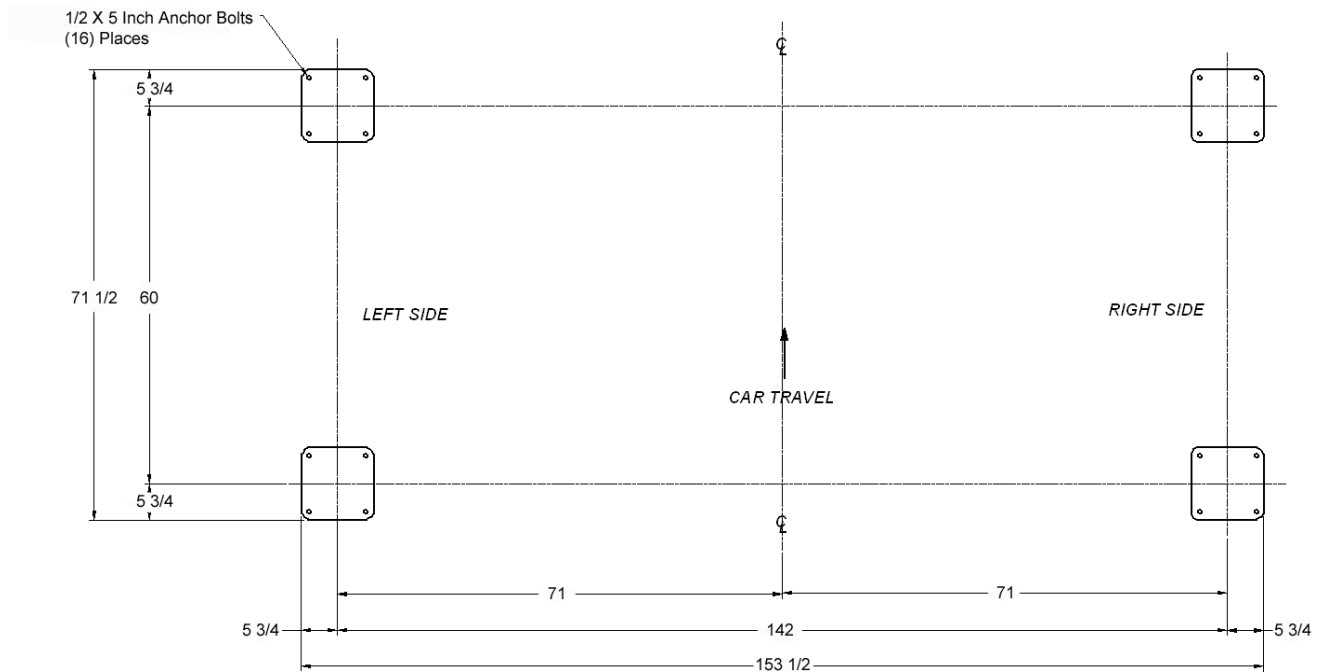

**Figure 3-8. Base Plate Positioning**

- 22. Set the non-conveyor side of the brush using the dimensions shown. Secure to the concrete floor in the same manner as the conveyor side of the Tire Washer. Check for freedom of movement and arm clearance.

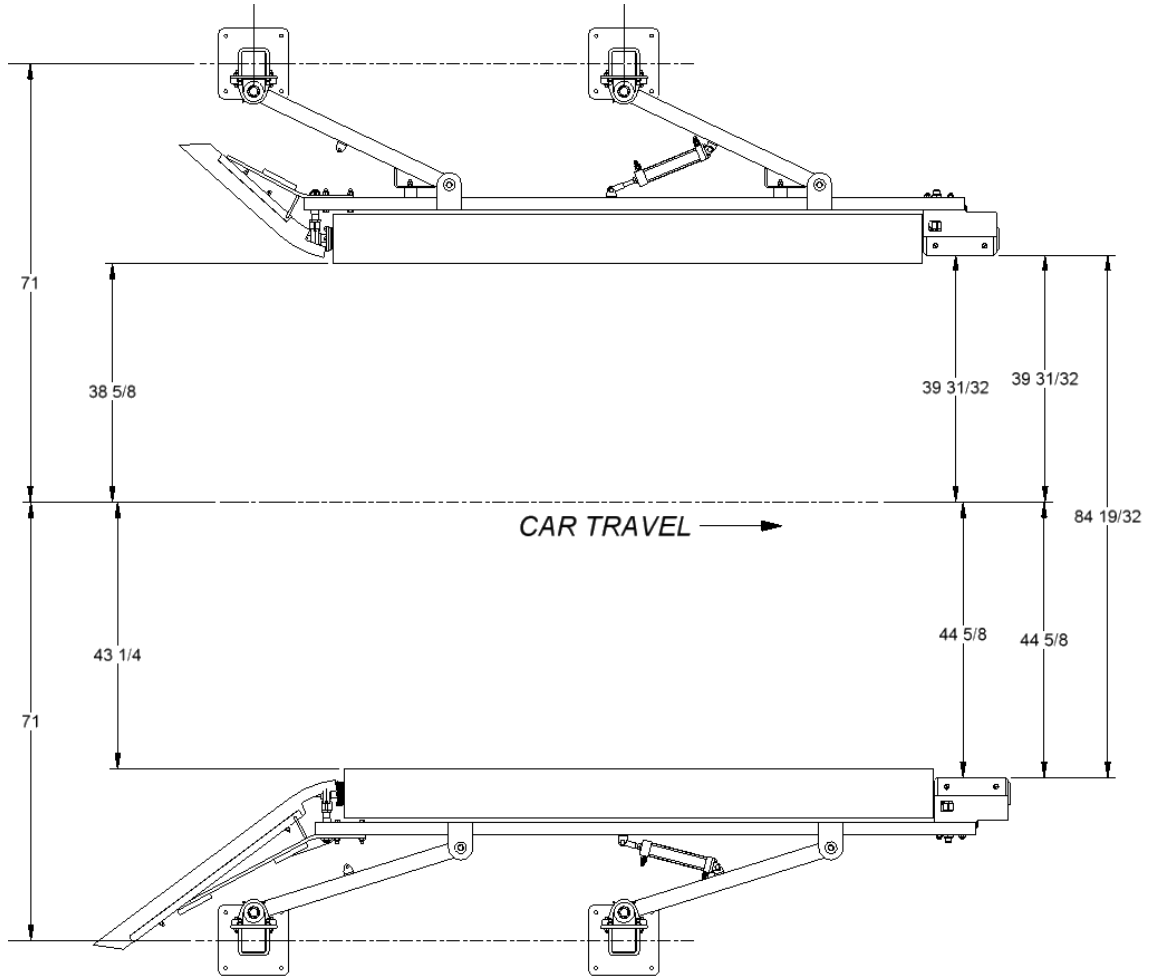

Figure 3-9. Mounted Tire Washer With Dimensions



23. If the structure is installed correctly the arms of the tire washer will extend and retract without interfering with the other equipment.

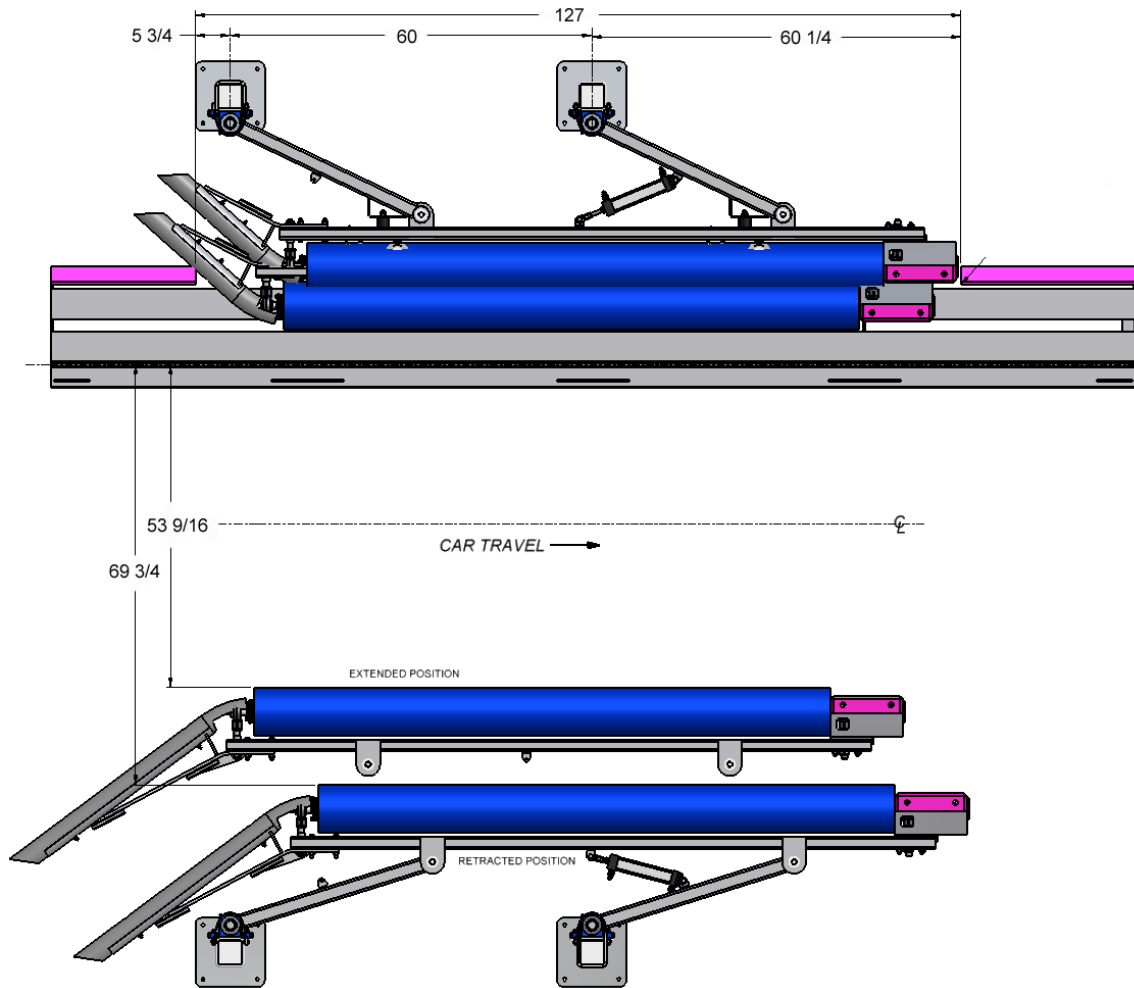

Figure 3-10. Mounted Tire Washer With Extend and Retract Dimensions

### 3.4.3 Height Adjustments

Adjust height from floor to brush centerline based on the conditions described below

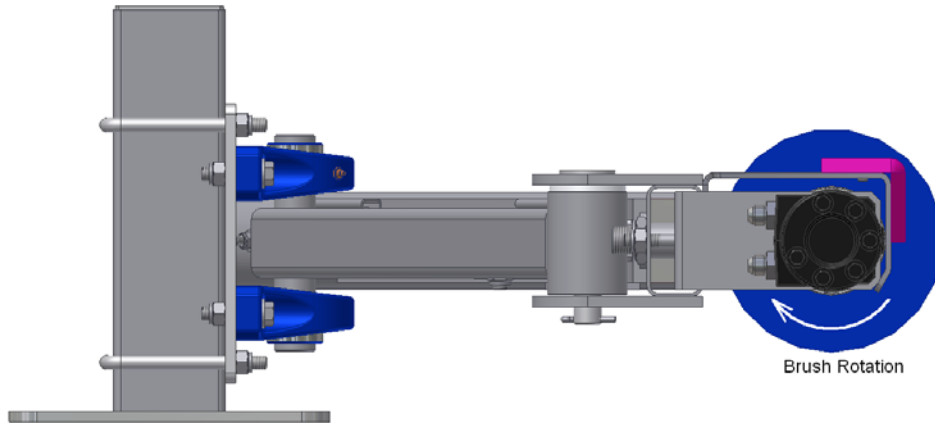

Figure 3-11. Side View With Brush Rotation

24. Conveyor Side HHSC/RCV and 3-Wheel Pushers High and Low Profile will have a 6 1/2" Height

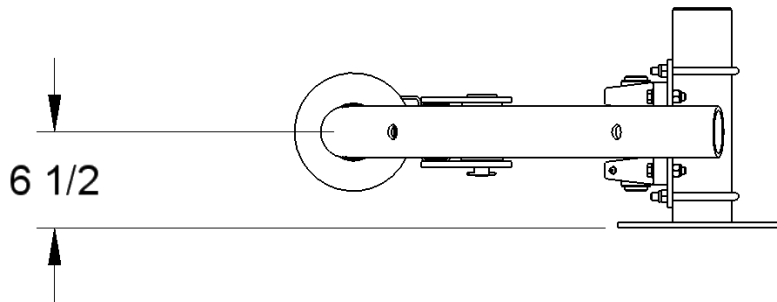

Figure 3-12. 6 1/2" Brush Clearance From Ground

25. Conveyor Side 6 Wheel High Profile Pushers will have a 7" Height

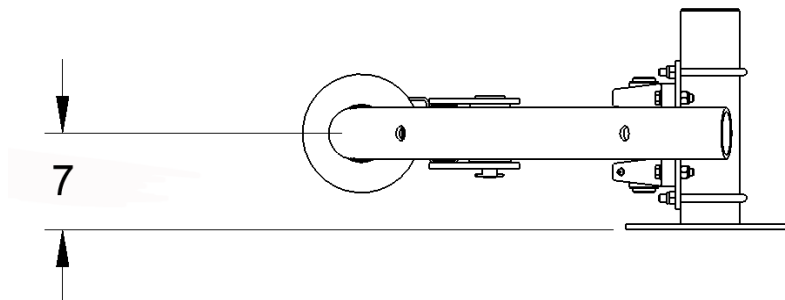

Figure 3-13. 7" Brush Clearance From Ground

26. Conveyor Side 6 Wheel Low Profile Pusher will have a 6 ½" Height

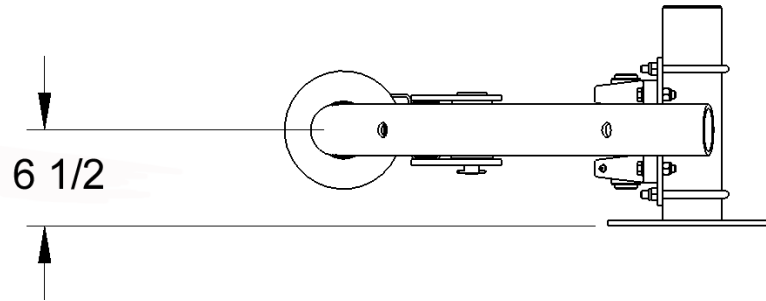

Figure 3-14. 6 ½" Brush Clearance From Ground

27. Non-conveyor Side HHSC/RCV and 3-Wheel Pushers High and Low Profile will have a 4 ½" Height

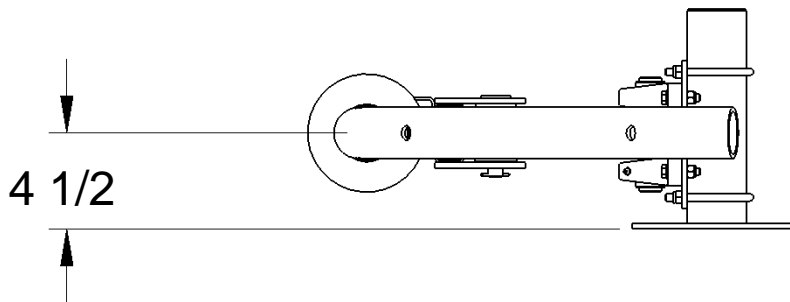

Figure 3-15. 4 ½" Brush Clearance From Ground

28. To modify the clearance heights simply loosen the u-bolts attached to the post and jacking bolt at the bottom of the mounting place
29. In some locations, removal of the jacking bolt on the passenger side may be needed to lower the brush to the correct height. Make sure to check the level of arms from rest to retract movement. Shim between the base plate and the post to correct.

### 3.5 Pneumatic Connections

30. The cylinder assemblies on the Hanna Tire Washer require a total of four 3/8" poly air hose connections. Included are two tee-fitting connections (one tee fitting for extend motion and one tee fitting for the retract motion). Figure 1-4 portrays the pneumatic cylinder for controlling the extend and retract command to the air cylinders. Figure 1-5 portrays the air hose diagram from the pneumatic board to the pneumatic cylinders.

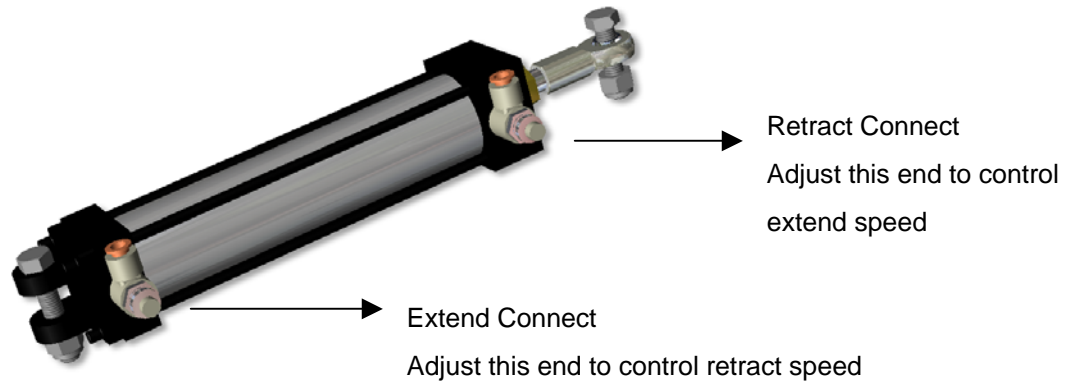

Figure 3-16. *Pneumatic Cylinder Assembly*

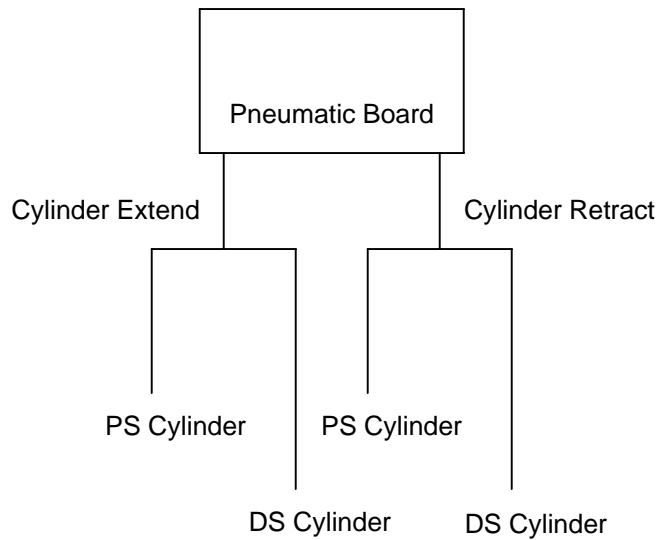

Figure 3-17. *Air Hose Diagram From Pneumatic Board to Cylinders*

31. During runtime, use the pneumatic flow adjuster on the cylinder to create a smoother extend and retract movement. Turning the airflow adjustment knob inward slows movement. Use the stop adjustment ring to lock the adjustment screw.
32. If a high air pressure is needed to retract the brush, but this pressure is too high when the brush is on the tire, check the arm level. Arms should be level during in and out travel. Refer to the height adjustment section of this manual to correct leveling of arms.



**Figure 3-18. Pneumatic Flow Adjustment**

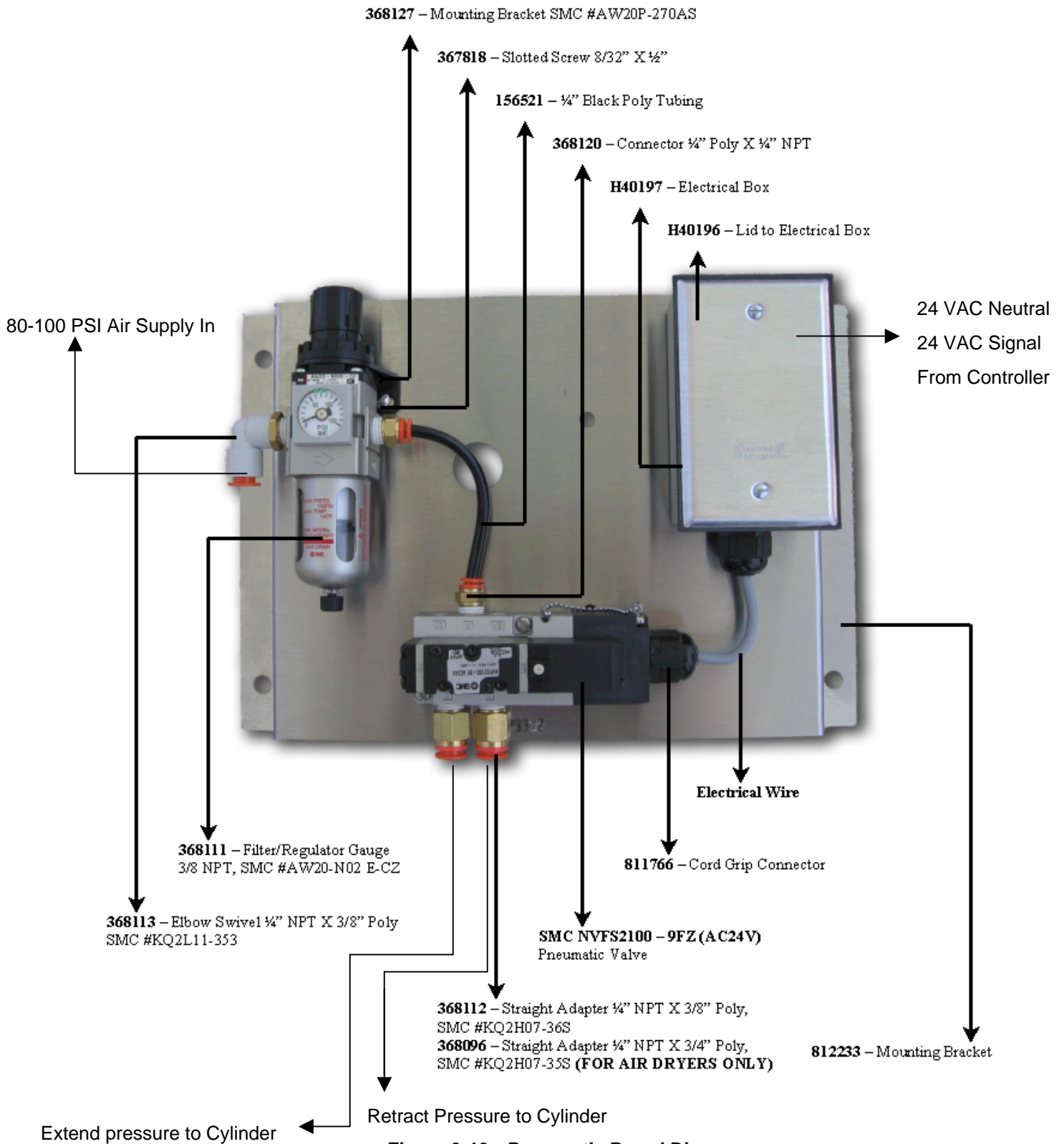

Figure 3-19. Pneumatic Board Diagram

### 3.6 Hydraulic Connections

33. A **4.3 GPM flow rate** at a pressure of **200PSI** is required out of one priority valve from the hydraulic unit. **200 RPM** is the recommended rotation speed of the motor, which is established from the priority valve on the hydraulic unit.
34. One end of one of the motors will have the hydraulic feed line, and the other end of the other motor will have the return hydraulic line. See the figure below for a hydraulic flow diagram of the Tire Washer motors.

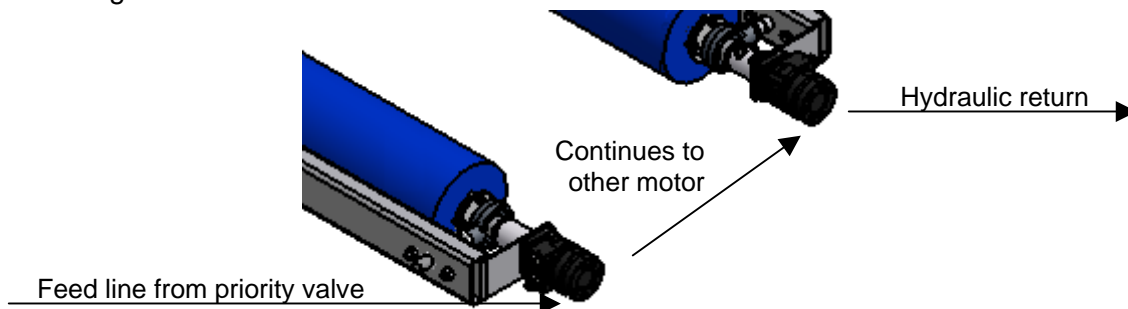

Figure 3-20. *Hydraulic Flow of the Tire Washer*

35. Install all hydraulic lines and fittings. Be sure to properly install Triple-Loc fittings by tightening by hand first then using the wrench make one full turn then an additional  $\frac{3}{4}$  turn.

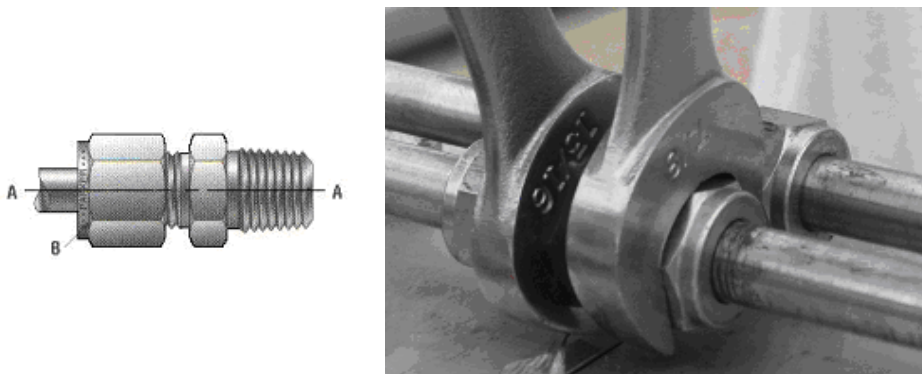
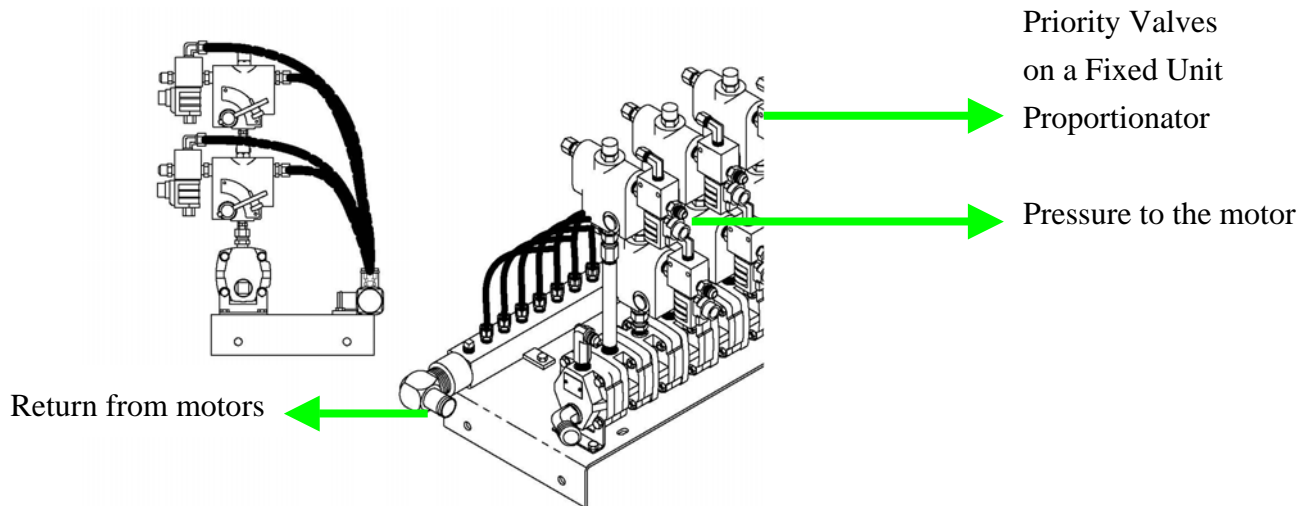

Figure 3-21. *Tightening the Triple-Loc Fitting*

36. Connect hydraulic lines (both pressure and return) from the Tire Washer to the Hydraulic Power unit.
37. Connect (electrically) the hydraulic solenoid (provided with the hydraulic unit)



**Figure 3-22. Priority Valve Adjustment on the Proportionator**

38. Operate the Tire Washer. Start the hydraulic flow slowly, and gradually increase flow until operating speed is reached. Motor speed should be 200 RPM.
39. Check for hydraulic leaks and smooth operation.



## **3.7 Startup**

40. As the vehicle approaches, the hydraulic solenoid is energized and the brushes begin to rotate.
41. The extend function is energized just as the wheel approaches the point where the brush meets the tire. This function is energized, and held until both tires have been completely washed
42. The brushes are then retracted and the hydraulics are de-activated.

### **3.7.1 Standard Mode**

43. In the standard mode, the tire washer is used in every wash package
44. To use the tire washer in standard mode, the cylinder is left extended the entire time.
45. The air regulator is used to adjust the force which the Tire Washer pushes against the vehicle
46. No solenoid or signal is required, other than for hydraulic location.

### **3.7.2 On-Demand Mode**

47. In the "On-Demand" mode, the Tire Washer is used only in the upgraded wash packages chose by the paying customer.
48. To use the Tire Washer in the on-demand mode, the Tire Washer is left in the retracted position. When the appropriate wash package is selected, a 24VAC signal is sent to the pneumatic and the hydraulic rotation solenoids.
49. This will then energize the pneumatic valve and cause the cylinder to extend, pushing the brush to the out position. The brush will also begin to rotate.
50. The air regulator is used to adjust the force that the Tire Washer applies to the tire.
51. Once the vehicle has cleared the Tire Washer, the signal is cancelled and the brush returns to its retracted position.

### 3.8 Installation Check List

Make sure that all installation procedures have been checked and confirmed to be correct.

Check Off	Install Procedure
	Convey guide rail has been cut and modified to perfectly fit the Tire Washer
	Structure is mounted over the centerline
	All bearing grease fittings have been greased and identified for future use
	The bumper stops have been positioned and secured
	Cylinder assemblies have been properly attached and installed
	Pneumatic control is installed
	Pneumatic connections lead to the correct ports
	Arms and brushes are level
	Brushes are perfectly parallel to the conveyor
	Hydraulic connections are installed and are ran with the correct volume and pressure
	Electrical connections are installed and are ran with correct timing and power requirements
	Brush RPM has been checked and are turning in the correct direction
	Start up procedures have been read and understood

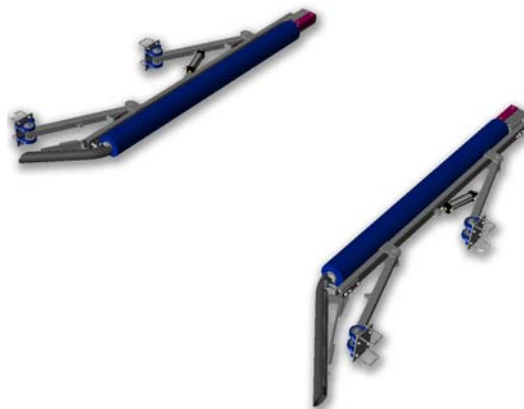

### 3.9 Hanna Hydraulic Tubing Color Code

Hanna uses colored tape on all hydraulic tubing at the factory. Figure 3-14 shows the color code on all Hanna hydraulic operated equipment.



# HANNA

















<b>HYDRAULIC TUBING COLOR CODE</b>		
<b>EQUIPMENT</b>	<b>COLOR CODE</b>	
Pressure Line	1 Stripe	
Return Line	2 Stripes	
Wraparound 98-C or Flex	Black	
Tire Washer	Brown	
HCRP	White	
Auto Prep	Purple	
SHWW or ASWW	Green	
Mitter Any Model	Blue	
Top Washer or Any Mitter	Yellow	
<b>SPARE COLORS</b>		
Also Code the Following:		
Superwave, High PSI Arch	Red	
and Any 2nd Brush in Syst.	Orange	
<b>Multi Equipment Combo's</b>		
1st Mitter in System	Blue	
2nd Mitter	Yellow	
3rd Mitter	Red	
1st ASWW in System	Green	
2nd ASWW	Orange	
3rd ASWW	Red	

Figure 3-23. Hydraulic Color Coding

## **4.0 Parts and Maintenance**

### **4.1 General Maintenance**

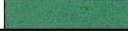
The Hanna Tire Washer requires periodic inspection and maintenance. However, there are only a few items that should be inspected on a regular basis. For the first month of operation check, on a weekly basis, hardware for tightness, bearings, vertical-mount legs, anchor bolts, and motor mounts.

#### **4.1.1 Daily Maintenance**

- ✓ Grease Spindle Bearings
- ✓ Check the unit for proper operation prior to washing the first vehicle each day
- ✓ Check for hydraulic leaks

#### **4.1.2 Weekly Maintenance**

- ✓ Check solenoid valve for positive on/off operation
- ✓ Check alignment of brushes
- ✓ Check bearings for proper vertical alignment
- ✓ Grease arm bearings

#### **4.1.3 Monthly Maintenance**

- ✓ Check hydraulic lines and water hoses for wear or rub
- ✓ Check frame, legs, and cross beams for cleanliness
- ✓ Check frame, legs, and supports for cracks and loose bolts
- ✓ Check all bearings for wear

## 4.2 Lubrication

Any lubrication program is only as good as the lubricants used. So we suggest you review this information and stock up on the best lubricants available.

It is recommended that once you decide on a type of grease that you stick to the same type of grease when you lubricate your bearings.

Daily: Lubricate brush spindle bearings using high-quality multi-purpose lithium grease.

Weekly: Lubricate arm bearings using high-quality multi-purpose lithium grease.

There are two types of bearing used for the Hanna Tire Washer: (8) Pillow block bearings used for arm movement, and (4) rod-end bearings used for brush rotation.

Over time these bearings will require replacement and some disassembly of the Tire Washer will be required.

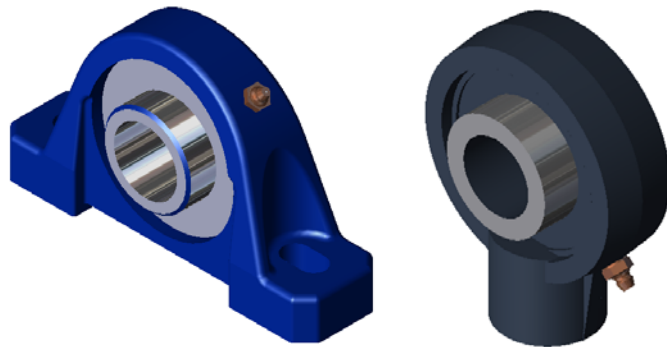
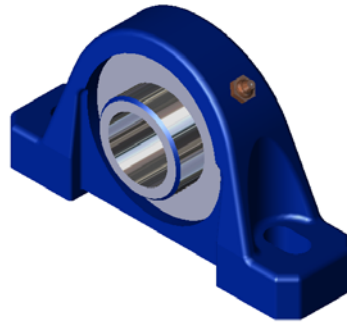

**Figure 4-1. Arm Bearing (left) and Hangar Brush Spindle Bearing (right)**

### 4.3 Spare and Replacement Parts List



802125 – Brush Assy - Poly



010439 – Pillow Block Bearing



367981 – Hangar Bearing



366065 – Hydraulic Motor

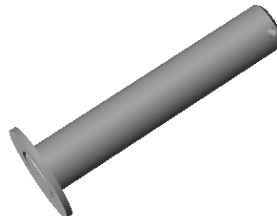

802032 – Brush Bar Pin

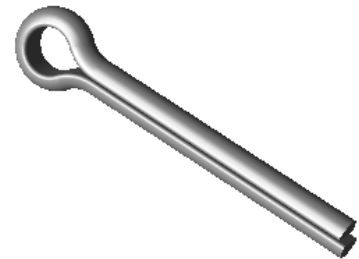

361263 – Cotter Pin

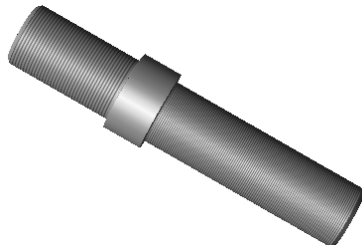

804764 – Bearing Pin



802127 – PS PVC Bumper



3802128 – DS PVC Bumper

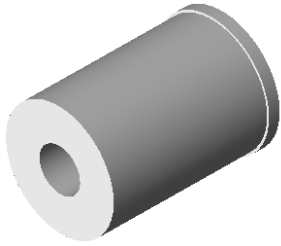

802042 – Bushing



070292 – Pneumatic Cylinder

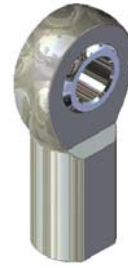

367094 – Rod-End Bearing



368068 – Flow Control Fitting

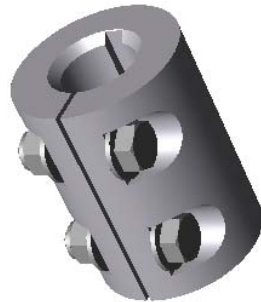

231753 – Split Coupling Assembly

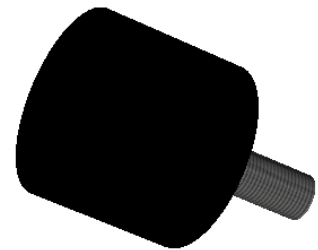

091363 – Rubber Stop

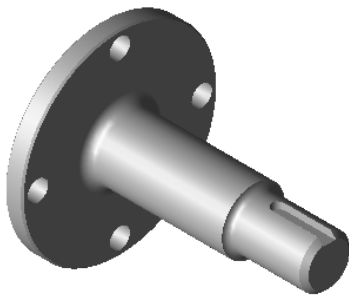

247270 – Drive Spindle

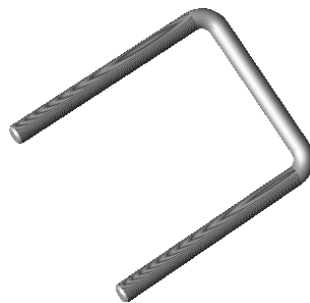

363057 – U-Bolt

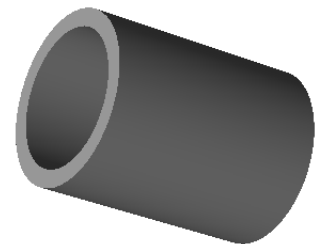

814167 – Pipe Spacer



**Jim Coleman Company/Hanna Car Wash Systems**

*Main Office*

5842 West 34<sup>th</sup> Street  
Houston, TX 77092

800-999-9878 • 713-683-9878 • Fax: 713-683-9624  
[www.jcolemanco.com](http://www.jcolemanco.com)

*Hanna Division Office*

7905 Blankenship Dr.  
Houston, TX 77055

866-683-6615 • 713-683-6615 • Fax: 713-590-6630  
[www.hannacarwash.com](http://www.hannacarwash.com)





**Jim Coleman Company/Hanna Car Wash Systems**

*Main Office*

5842 West 34<sup>th</sup> Street  
Houston, TX 77092

800-999-9878 • 713-683-9878 • Fax: 713-683-9624  
[www.jcolemanco.com](http://www.jcolemanco.com)

*Hanna Division Office*

7905 Blankenship Dr.  
Houston, TX 77055

866-683-6615 • 713-683-6615 • Fax: 713-590-6630  
[www.hannacarwash.com](http://www.hannacarwash.com)