

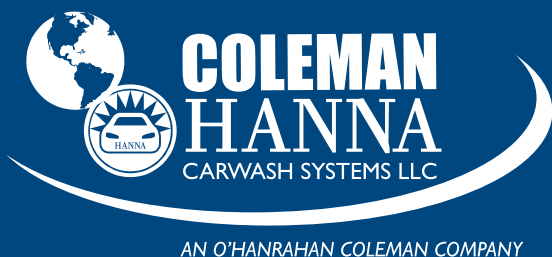

Swipe N Clean 1.0

Owner's Manual



5842 W 34th St • Houston, TX 77092

1.800.999.9878 1.713.683.9878

www.colemanhanna.com



Find us on Facebook:
/ColemanHannaCarwash

HISTORY OF JIM COLEMAN COMPANY

Jim Coleman Company, located in Houston, Texas, is a privately owned company formed in 1966 to achieve goals through quality products and dedicated services. Because we believe strongly in employee excellence, we rely on well-trained and competent employees to help operate our business. Our special combination of enthusiasm and experience has given us the base needed to achieve solid and steady growth.

By choice, Jim Coleman Company is and will continue to be a private company. We have chosen our 140 employees as carefully as we have tested our products. Jim Coleman Company employees and their welfare are very important to the success of the company. The long-range objective is for continuous development of a growing and prospering business, through which both employees and company will benefit. Every employee is considered a member of the company team and the success of the company is built on the recognition of the skills and efforts made by each employee

Our modern manufacturing facility has 90,000 square feet of production space on a single property. This allows total manufacturing control which, backed by our rigid testing procedures, enables us to produce outstanding products with cost-effectiveness. We are constantly looking for ways to improve our products and services. Our production staff's attention to detail pays off in user satisfaction.

Quality at Jim Coleman Company is not an accident; it is the result of earnest intelligent team effort. This goal is accomplished through painstaking detail attention to every phase of manufacturing. Every effort is taken to ensure that our products are the very best in the industry.

Jim Coleman Company enjoys an international distribution network for marketing of its products which are sold throughout the United States and in such countries as Mexico, Canada, South America, New Zealand, Australia, France, Spain, Iceland, and the United Kingdom.

We have built our business with "people-experienced" people who adhere to detail and strict dimensional tolerances, a hallmark of Jim Coleman Company. Each of our manufactured products must undergo and pass numerous individual checks: from raw material to the final finished product. When the moment arrives for our well-known trade mark name, "*SPARKLE*", to be placed on a piece of our car wash equipment, one essential factor stands above all others - performance credibility.

“WE OFFER COMPLETE SERVICE TO THE CAR WASH INDUSTRY”.

In addition to our complete line of Sparkle equipment and car wash supplies, Jim Coleman Company can assist in planning and setting up a car wash. Our knowledge and experience in site selection, land usage design, engineering and construction enable us to provide qualified advice and proper direction. We offer our team effort as a service in helping to develop a successful, low-maintenance car wash business. Our production staff has the experience to ensure the latest design and technology is incorporated into each project.

TABLE OF CONTENTS

I.	INTRODUCTION	I-1
II.	COMPONENTS	
	Swipe-N-Clean Cabinet	II-1
	Bay Push Button Controller Board	II-2
	Bay Push Button Controller Board – Solenoid Detail	II-3
	Vacuum Push Button Controller Board	II-4
	Vacuum Push Button Controller Board – Solenoid Detail	II-5
	Point of Sale Push Button Controller Board	II-6
	Vendor Push Button Controller Board	II-7
	Vendor Push Button Controller Board – Solenoid Detail	II-8
	1034 Timer	II-9
III.	OPERATION	
	Mounting Specifications	III-1
	Operation Concept	III-2
	Operating the Swipe-n-Clean	III-2
	Inputting Use Code at the Bay Meters	III-3
	Inputting Use Code at the Vacuums	III-5
	Printed Receipt	III-7
	Special Actions that will happen	III-8
IV.	INSTALLATION	
	Pre-Planning Steps	IV-1
	Cabinet Installation	IV-2
	Electrical	IV-3
	Communication Cables	IV-5
	Bays	IV-5
	Vacuums	IV-8
	Printer Maintenance	IV-9
	Installing Paper	IV-10
	Paper Loading Steps	IV-11
	1039 Monitor Installation	IV-12
	Changer Connections	IV-14
	Door Connection	IV-16
V.	PROGRAMMING INSTRUCTIONS	
	1034S Timer	V-1
	Push Button Controller Boards (PBC) Wash Vac and Vender	V-4
	Operating Instructions Push Button Controller Board (PBC) Wash-Vac-Vend	V-7
VI.	SYSTEM START-UP AND DAILY OPERATING FUNCTIONS	
	System Start-Up	VI-1
	IC Verify	VI-2
	Previewing and Settling Transactions	VI-3
	Reporting	VI-4
	Issuing Credit to a Customer	VI-5

VII. INCOME MONITORING & REPORTING ONLINE – SWIPE-N-CLEAN ONLINE

Getting Started VII-1

Getting Connected VII-3

Site Information Form VII-5

Income Monitoring Menus – Reports VII-6

 Reports VII-8

 Summary Reports VII-9

 Weekly Summary by Day VII-10

 Bay Income Report VII-11

 Vacuum Income Report VII-12

 Automatic Income Report VII-13

 Credit Card Deposit Report VII-14

 Changer Experience Report VII-15

 Functions Usage Report VII-16

 Door and Lights Activity Report VII-17

 Cash/Credit Past Earning Report VII-18

 Application Tax Information Report VII-19

 Fleet Account Billing Report VII-20

Income Monitoring Menus – Utilities

 Location Data VII-21

 Light Schedule VII-22

 Fleet Data

 Add Account VII-23

 Update/Change Account VII-24

 Delete Account VII-25

VIII. MAINTENANCE SCHEDULE VIII-1

IX. TECHNICAL TRAINING IX-1

X. TROUBLE-SHOOTING X-1

XI. GLOSSARY XI-1

INDEX

WARRANTY

Swipe-N-Clean®

Congratulations on your choice of Jim Coleman Company for your equipment provider and by selecting to use our newest product “SWIPE-N-CLEAN™”. This product allows you to tap into that otherwise unused resource of Credit Cards. Never before has a product so revolutionary and cutting edge been offered to the Self Service Car Wash Industry. In keeping with the long standing tradition of Jim Coleman Company once again we bring to our users the ability to make the most return on their invested dollar. Over 2 years of development and research has gone into this product delivering to you a stable and tested platform to take Credit Cards. The following is a list of the features that you will grow to appreciate in the future as a Car Wash Operator:

The **Only Credit Card Service** for the self-service Car Wash

- Vibrant Sound with Verbal Instructions
- 110 VAC Powered
- Printed Receipt
- Digital Keypad for Inputting
- Protected Card Reader
- Colorful Decal for User Awareness
- Heavy-Duty Stainless Steel Construction

“With Just a Swipe of a credit card, users can use the car wash by inputting a user code.”

“Users can easily input their user code to use any bay service.”

“Users can also use vacuum, shampooer and fragrance machine with their user code.”

“For a printed receipt, the user enters his/her user code.”

Swipe-N-Clean-Front View



Fig. II-1

SWIPE N CLEAN - FRONT VIEW

- 1. Swipe N Clean Decal
- 2. Display Screen
- 3. User Instructions
- 4. Audio Speakers
- 5. Magnetic Card Swipe Front
- 6. Keypad
- 7. Receipt Printer

Swipe-N-Clean-Rear View



Fig. II-2

SWIPE N CLEAN - REAR VIEW

- 10. Point of Sale PBC & Keypad Assembly
- 11. Magnetic Card Swipe Rear
- 12. Modem #1-Left
- 13. Modem #2-Right
- 14. Connector Ports
- 15. Fuse Block
- 16. Power Supply

- 8. Stainless Steel Cabinet
- 9. Printer Assembly

BAY PUSH BUTTON CONTROLLER BOARD

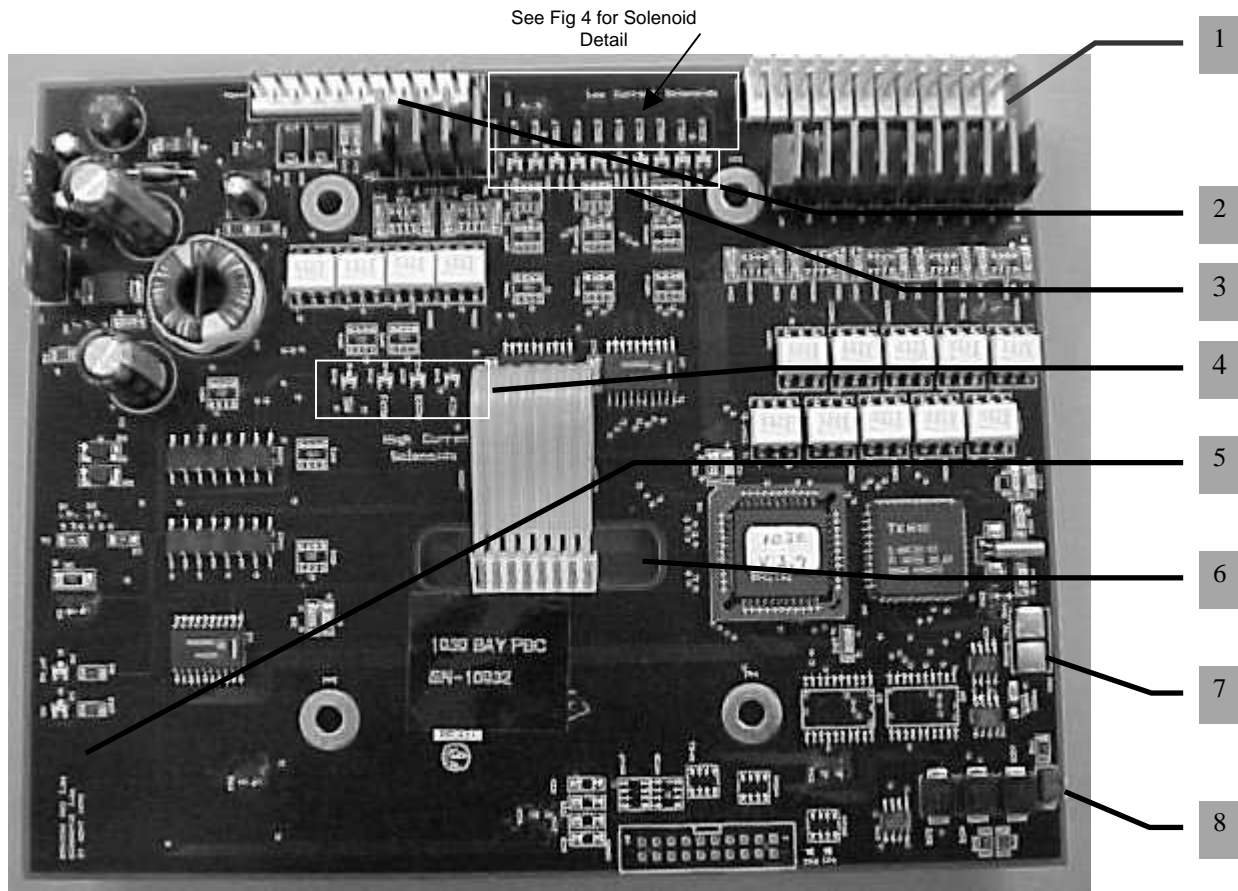

Fig. II-3

BAY PUSH BUTTON CONTROLLER BOARD

- 1. Function Connector
- 2. Power Connector
- 3. Function LED's
- 4. Pump Auxiliary Control LED's
- 5. 5v Volt Power LED's
- 6. Keypad Connector
- 7. Reset Shorting Connectors
- 8. RS 485 Connector Pin (2 Pin)

BAY PUSH BUTTON CONTROLLER BOARD-SOLENOID DETAIL

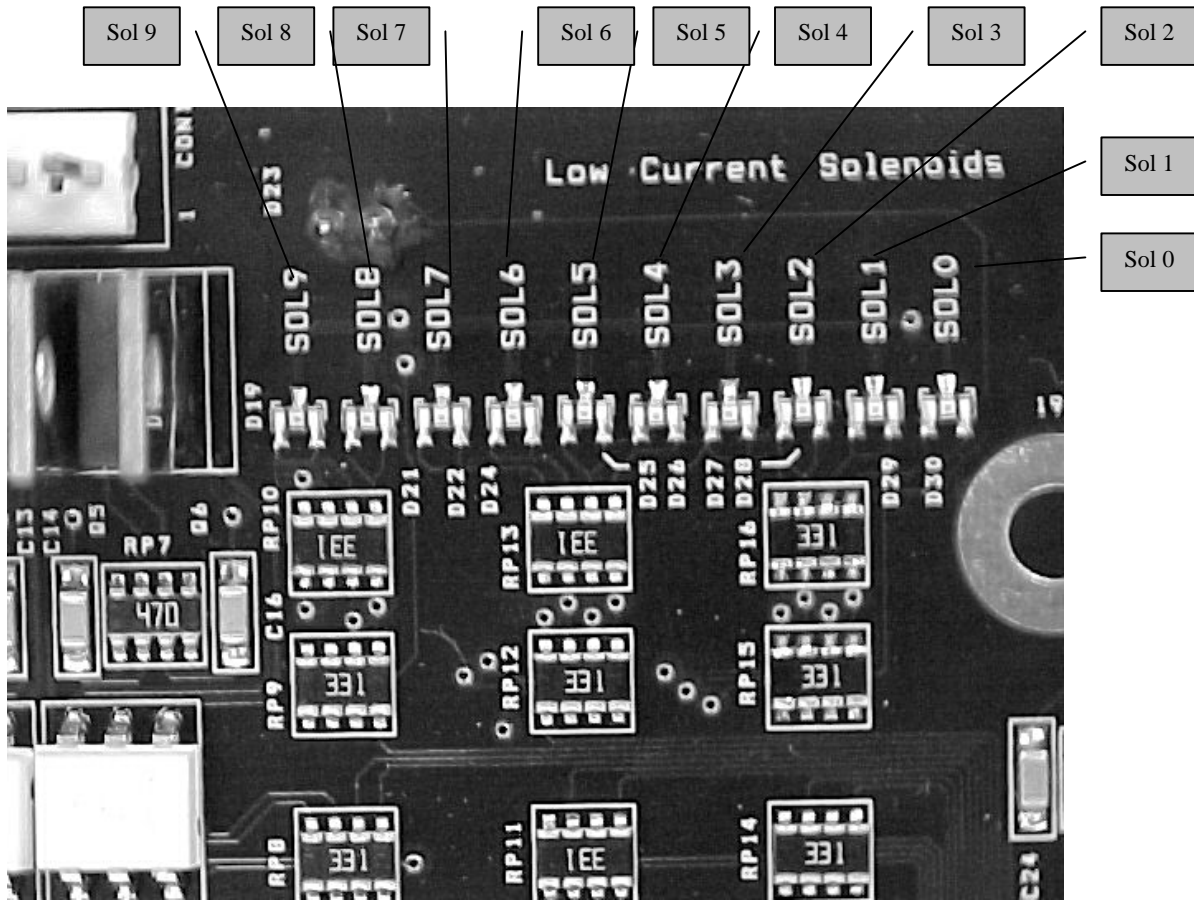

Fig. II-4

VACUUM PUSH BUTTON CONTROLLER BOARD

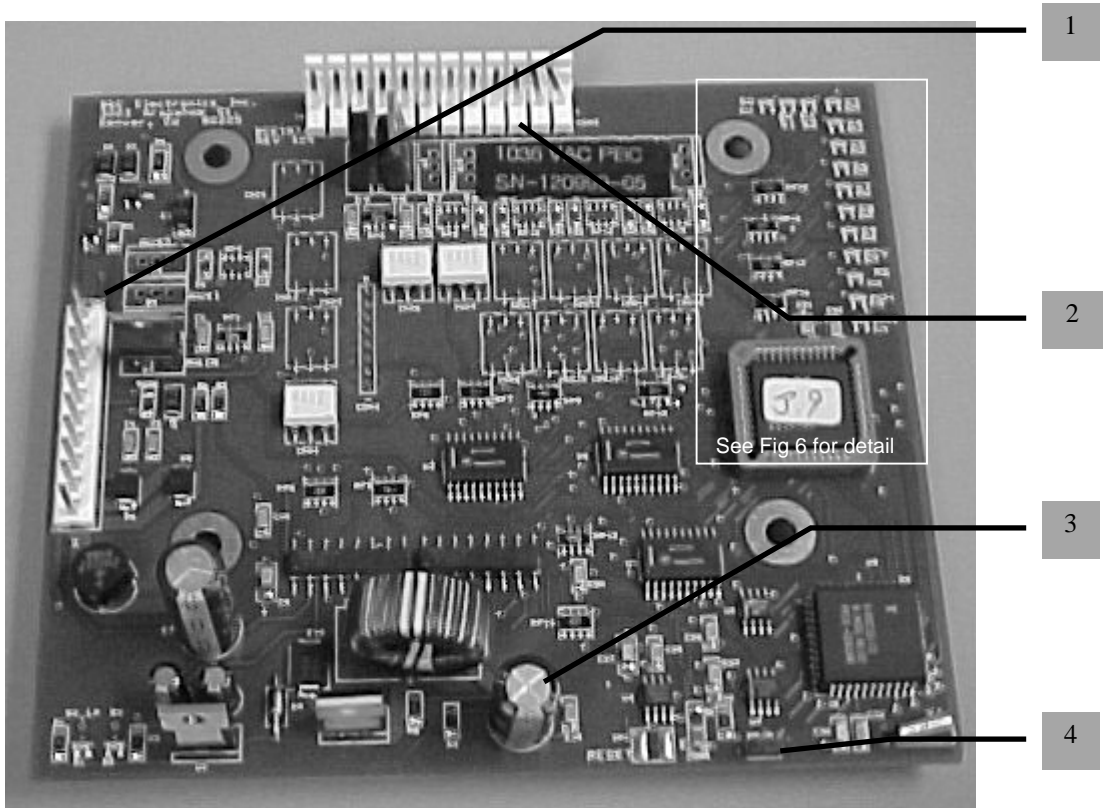

Fig. II- 5

VACUUM PUSH BUTTON CONTROLLER BOARD

- 1. Function Connector
- 2. Power Connector
- 3. 5 Volt Power LED's
- 4. RS 485 Connector Pin (2 Pin)

VACUUM PUSH BUTTON CONTROLLER BOARD (Enlarged View of Solenoid Detail)

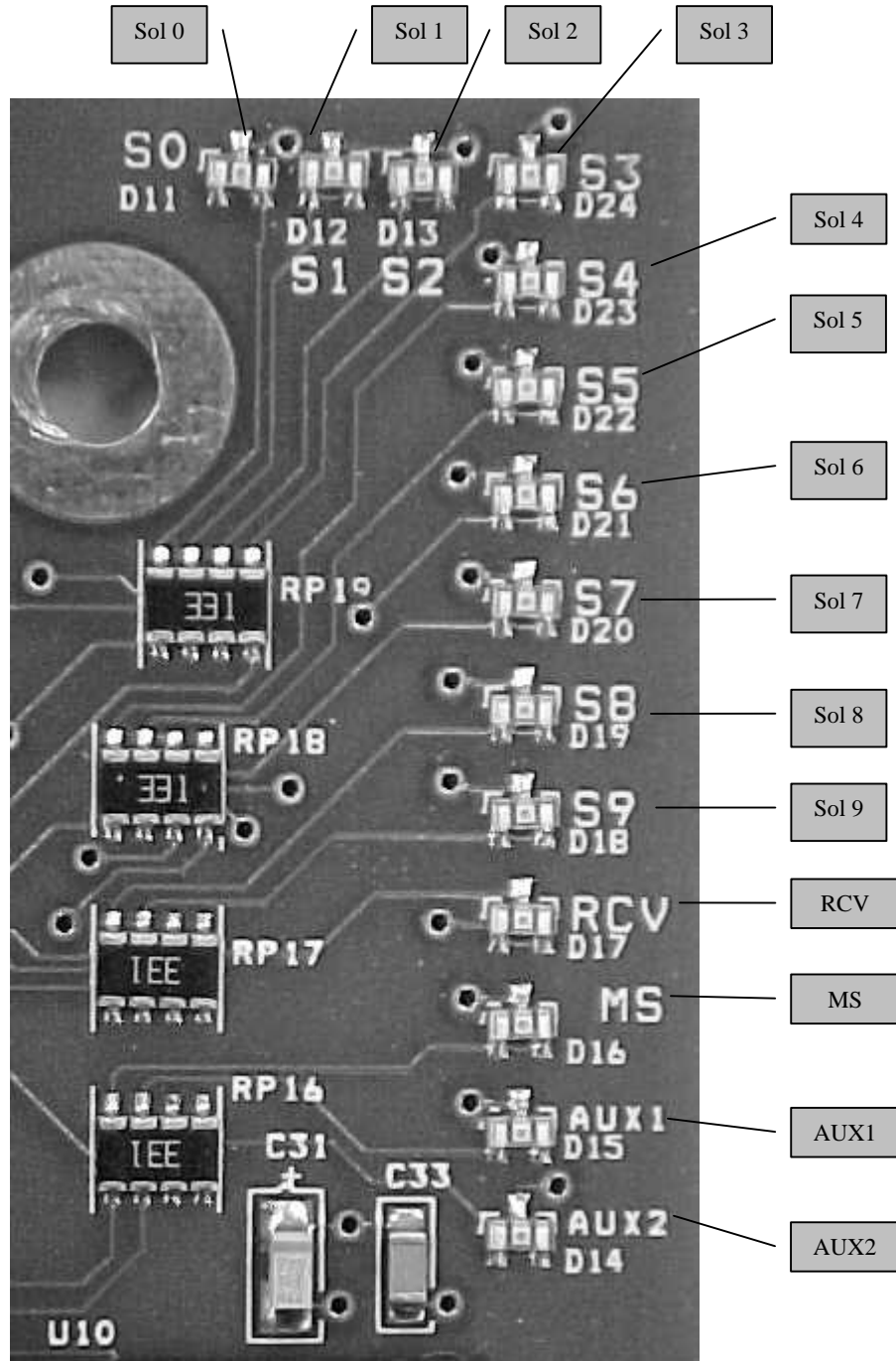

Fig. II-6

POINT OF SALE PUSH BUTTON CONTROLLER BOARD

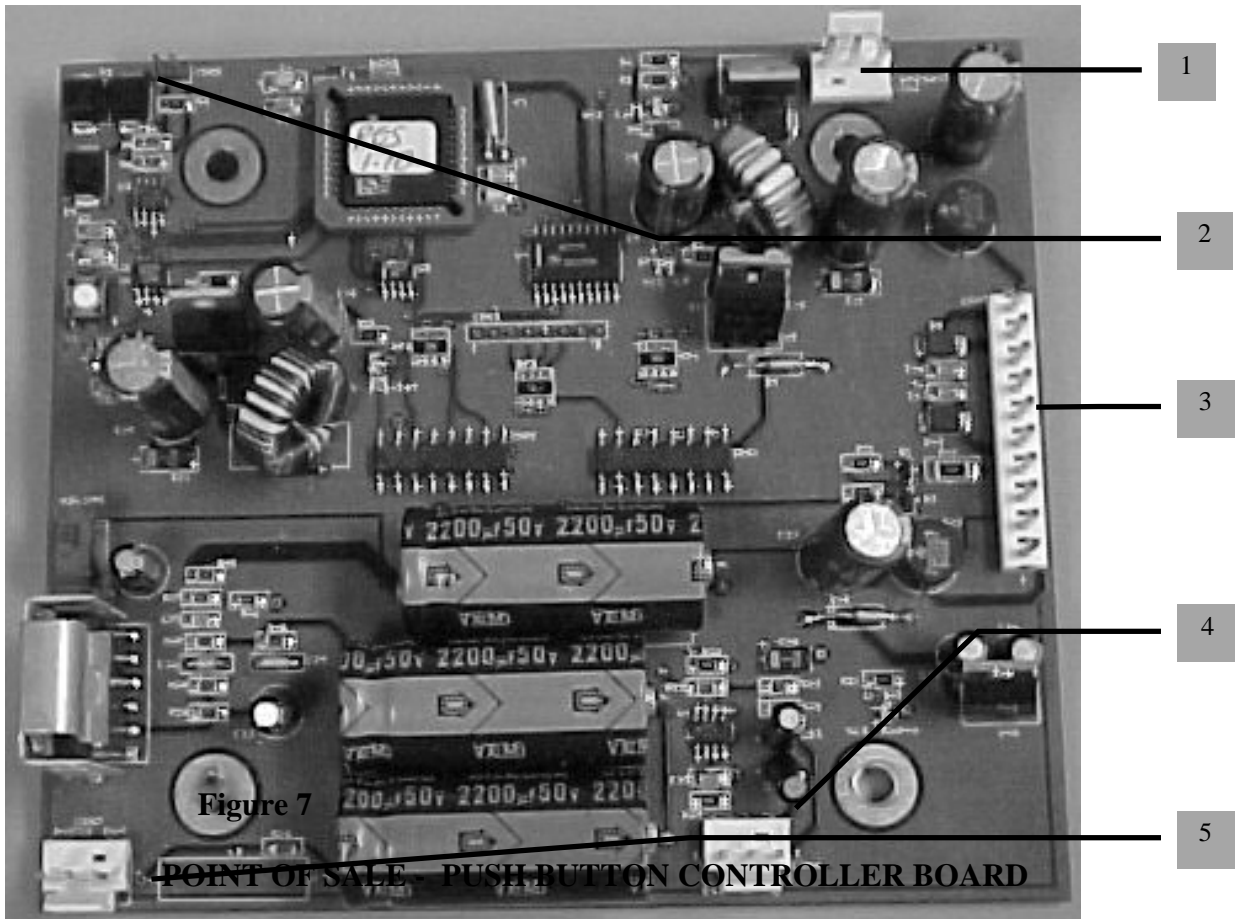

Fig. II-7

POINT OF SALE PUSH BUTTON CONTROLLER BOARD

1. CardSwipe Connector-5Volt DC
2. RS485 (2Pin) Connector (Brown Pin1)
3. 24VAC Connector
4. Audio Connector (Input)
5. Audio Connector (Output)

VENDOR PUSH BUTTON CONTROLLER BOARD

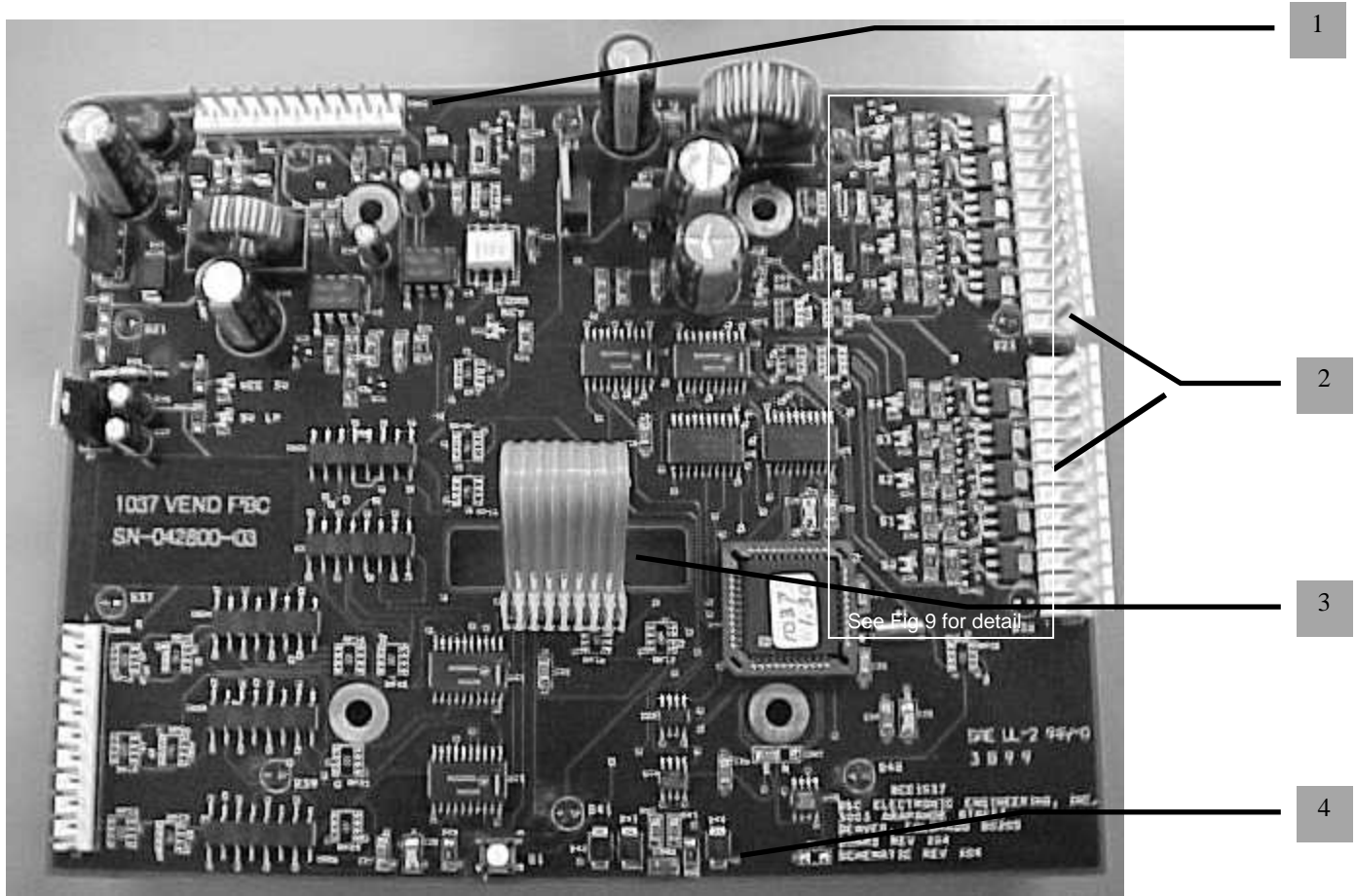

Fig. II-8

VENDOR - PUSH BUTTON CONTROLLER BOARD

- 1. Power Supply
- 2. Vendor Control Connectors
- 3. RS485 (2Pin) Connector (Brown Pin1)
- 4. 2 Tab Reset Pads

VENDOR PUSH BUTTON CONTROLLER BOARD (Enlarged View of Solenoid Detail)

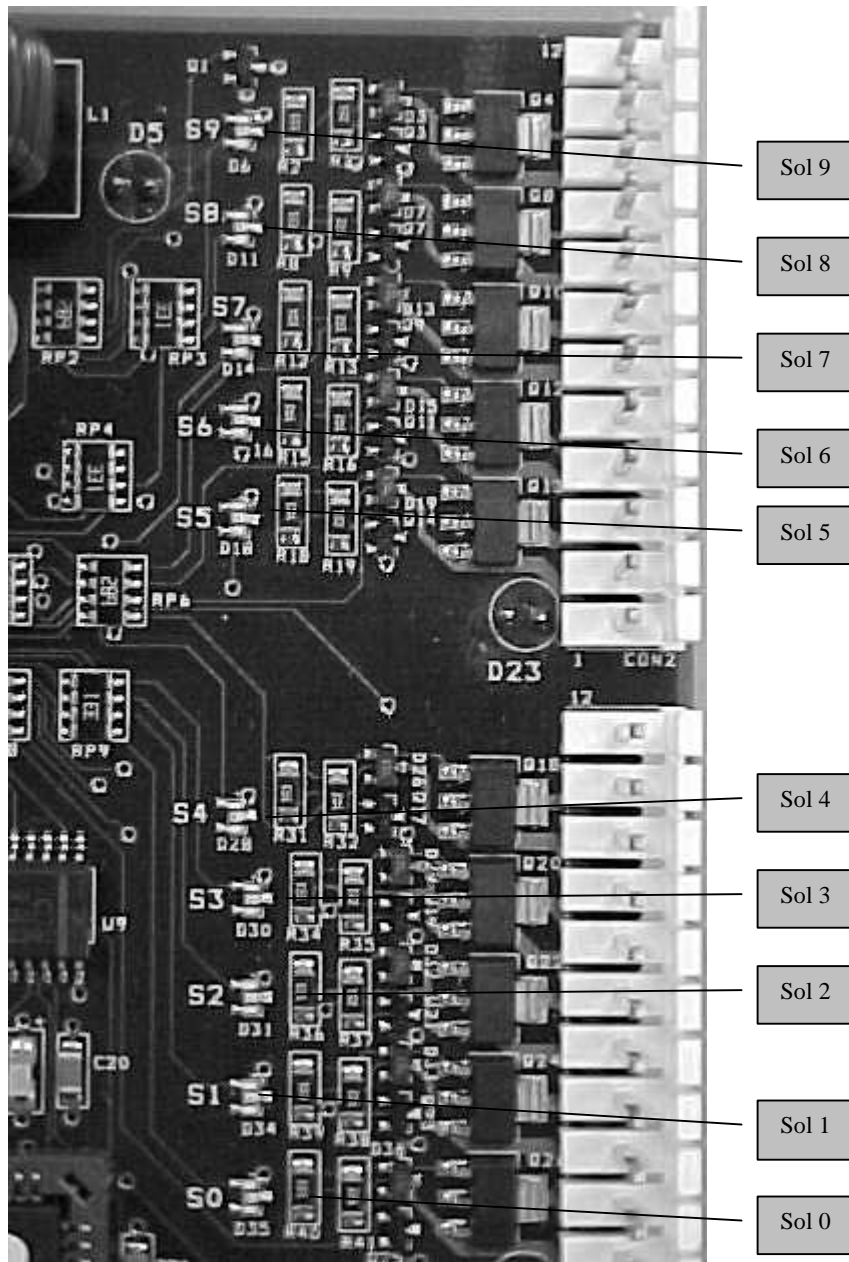

Fig. II-9

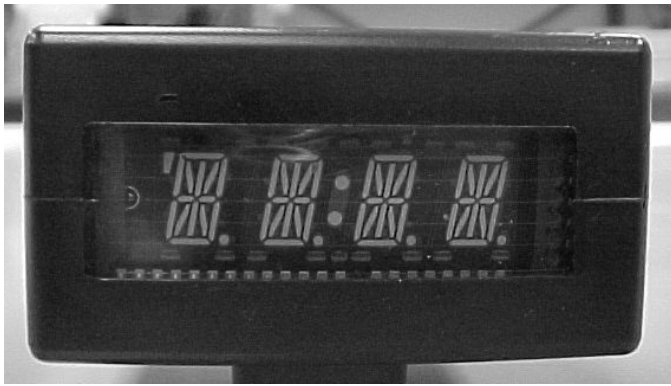

Fig. II-10 - Front View of Timer



Fig. II-11 - Rear View of Timer



Fig. II-12 - Twelve Position Keypad

Electrical Cabinet

110/120VAC 5 Amps

Electrical - Bays

24VAC 5 Amps

Electrical - Vacuums

24VAC 5 Amps

Electrical – Vendors

24VAC 5 Amps

Dimensions

Faceplate

Width - 27"

Height - 44"

Cabinet

Width - 25"

Height - 40"

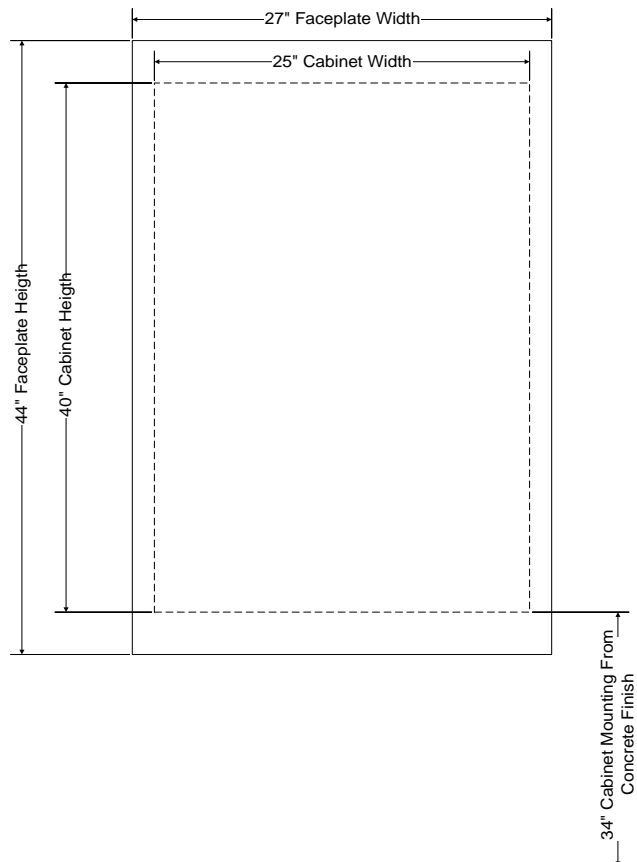

Figure III-1

OPERATION CONCEPT

The SWIPE-N-CLEAN™ (SNC) is an interface to make services accessible to credit card patrons. It allows patrons to wash up to a predetermined amount of time at the wash bays (i.e., \$10.00); to vacuum for one cycle per code entry at the vacuums; and to purchase one vending item per code entry at the electronic vendors all without using cash or coins. The following is a brief description of the operation of SNC. This description will help the owner/operator understand its operation.

Key Components:

- SNC Cabinet
- PC w/Windows NT 4.0 software
- Card Swipe Reader
- Point of Sale Push Button Controller (POS/PBC)
- Point of Sale 16-Position Keypad
- Point of Sale Printer
- Instruction Set
- 1034S Timer
- Select N Touch Bay Meters
- Select N Touch Vacuum Meters
- Select N Touch Vendor Meter(s)
- Function Selector 12-Position Keypad

Operation

Swiping a Credit Card - at the SNC:

Once the SNC is powered up, the amplified message will begin broadcasting from speakers on the front of the cabinet. The message brings the customer's attention to the system as a potential user. Users will swipe their card, with the card's magnetic stripe facing up and to the left as shown. (Fig. III-2)

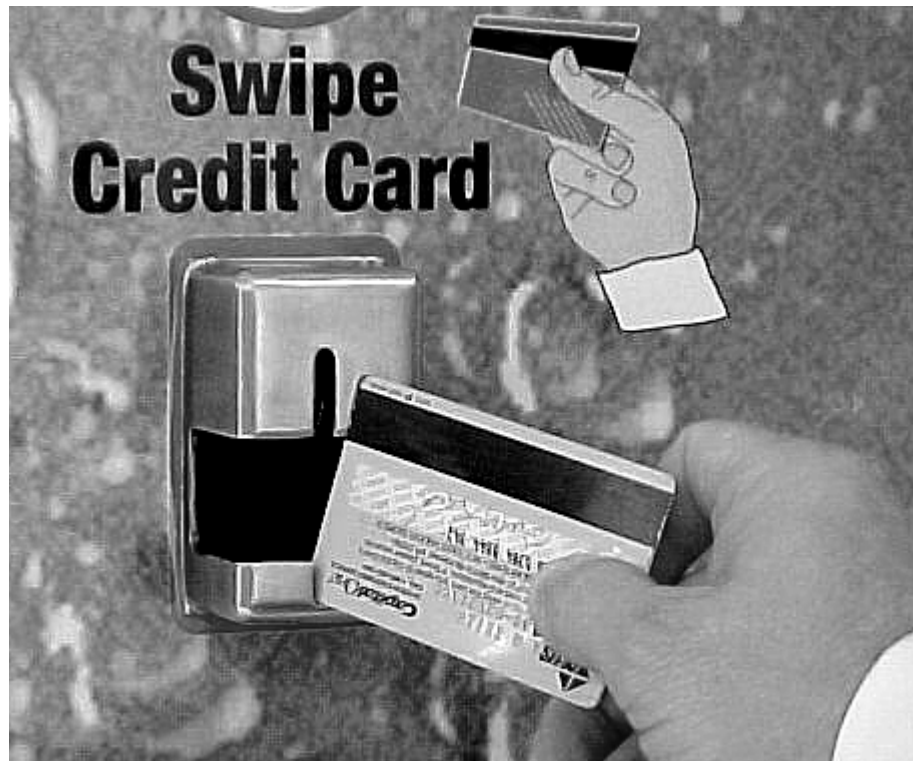

Figure III-1

Once a card has been swiped, the SNC announces: *“One Moment Please, while we processor your card”*. This will take from 5 to 30 seconds, depending on the traffic with the Credit Card Processor (CCP). Upon completion one of two actions will occur:

1. If the card cannot be approved, read, or is denied credit, the SNC will announce: *“We are sorry we are unable to process your card at this time, please try again or attempt to use another card”*. The user should either try their card again, or try to use another card.
2. If the card is approved the SNC will begin instructions on how to properly use the system. Most users will need to listen to the instructions at least once to understand the proper operations of the system. At any time while the instruction set is being announced, another user may swipe their card and get approval or input their use code and get a printed receipt. The SNC will then continue its instructions.

Inputting Use Code - At the Bay Meters:

One of the instructions the user will receive at the SNC is their *“use code”*; the access code the user will input to get services at the *bays, vacuums, or vendor island*. The use code is the last four digits of the users credit card followed by the “#” (pound) key. When properly input this code will *activate* the selected unit.

When the user returns to the bay or vacuum after getting their card approved, they will input their 4-digit use code, followed by the pound sign using the keypad on the Select N Touch (“SNT”) meter fronts (Fig. III-3)

OPERATION CONCEPT

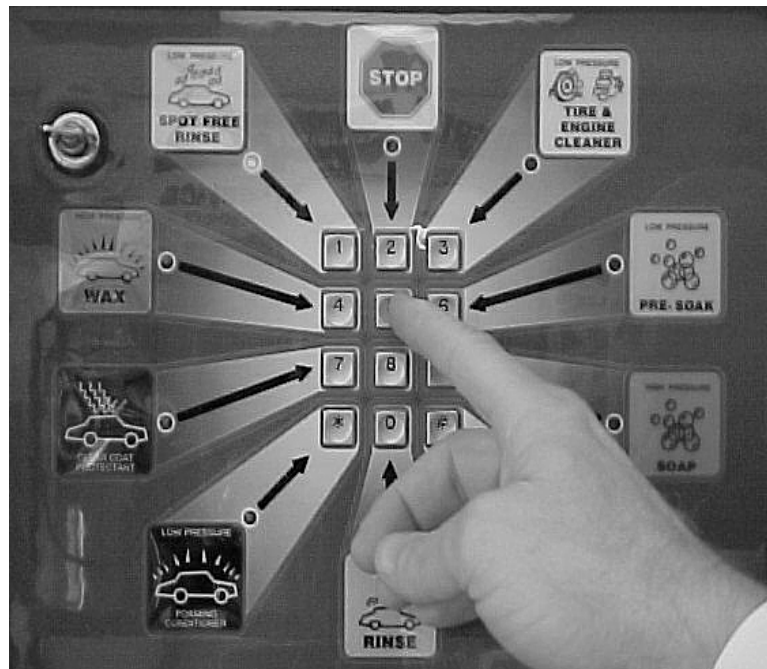

Figure III-2

Swipe-N-Clean Operating Manual

Each time the user pushes a number on the keypad, while inputting their code; the meter will beep, providing positive feedback. The “#” key enters the “*use code*”; if successful, the user will hear two consecutive beeps, indicating that their code has been accepted. If the two beeps are not heard, the user should verify that they are using the correct use code and then re-input it. Their use code should be input using a smooth, positive stroke on the keypad. There is a time limit of 7 seconds, built into the system for inputting the use code. If this time is exceeded then the user must re-input their use code. After hearing the two consecutive beeps, the user will observe the rotating lights on the Select-N-Touch bay meter have halted in the stop position awaiting their selection. They will also see the timer start flashing “Wash Now”. (Fig. III-4)



Figure III-3

The timer display will continue to flash until the user makes a product selection; the user is not being billed at this time. Once a user makes a selection the timer will access the wash at minimum turn on price and minimum start up time (i.e. \$1.00 / 4 minutes) then as the user continues past the turn on time the timer will continue to increment in \$.25 billing cycles until a preset amount is used or the stop position has been selected. (Fig. III-5)

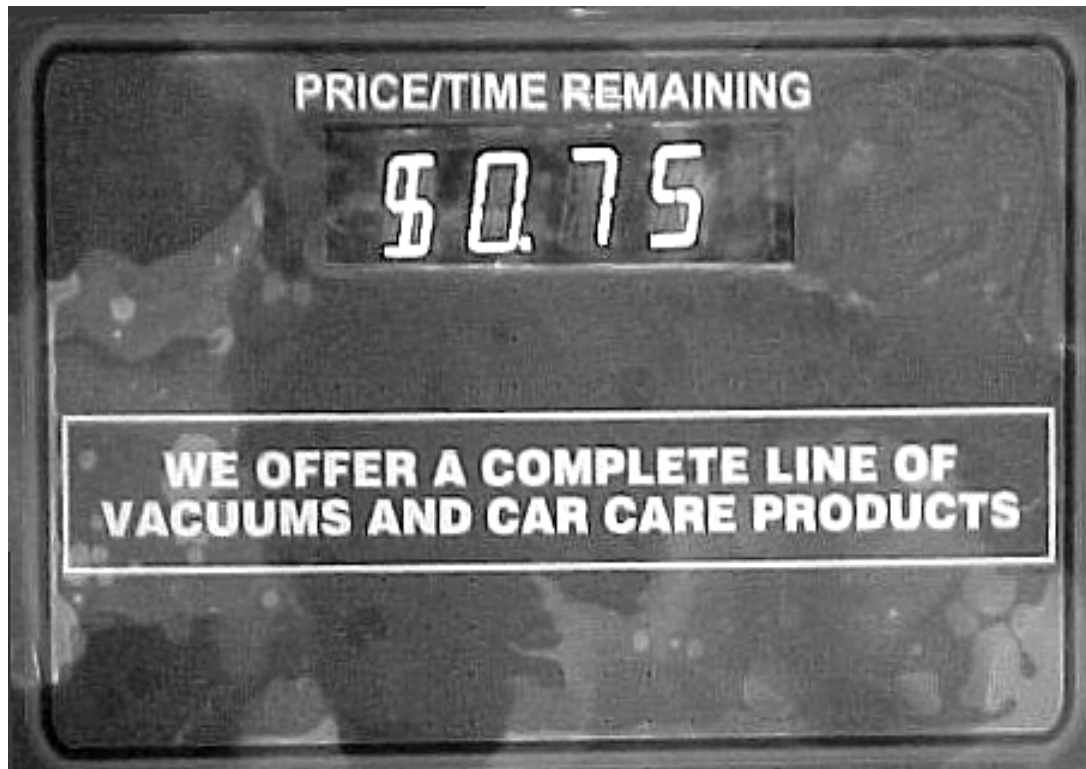

Figure III-4

OPERATION CONCEPT

The billing amount will be based upon the timer setup and turn-on price. A \$.25 charge will be made according to the H: menu setup in the timer. This is the amount of time, calculated or programmed; per additional quarter received, after the initial turn on price of the bay has been satisfied. The timer will continue to increment until the preset turn off is reached as long as the user is using the bay and has not selected the stop position. Once the user has completed their selections in the bay, they must choose stop to discontinue the billing cycle. Once “stop” has been selected the timer will display “bill \$X.XX” (\$X.XX=Amount to bill to users credit card). (Fig. III-6)



Figure 111-5

The user can re-input their use code and start another transaction while still in the bay, however the display will begin at minimum turn on price and minimum start up time (i.e. \$1.00 / 4 minutes) then as user continues past the turn on time the timer will begin to increment in \$.25 increments starting the billing cycle. (Fig. III-5)

Inputting Use Code - At the Vacuums:

At the vacuums, the user will input their 4-digit use code, followed by the pound “#” key on the Select-N-Touch vacuum meter fronts. Each time the user pushes a number on the keypad, while inputting their code; the meter will beep, providing positive feedback. The “#” key enters the “*use code*”; if successful, the user will hear two consecutive beeps, indicating that their code has been accepted. If the two beeps are not heard, the user should verify that they are using the correct use code and then re-input it. Their use code should be input using a smooth, positive stroke on the keypad. There is a time limit of 7 seconds, built into the system for inputting the use code. If this time is exceeded then the user must re-input their use code. After hearing the two consecutive beeps, the user will be able to select the function that they wish to use. The timer will now start flashing “Vac Now” followed by “Frag Now” or “Sham Now” whichever is applicable. The user will now push the corresponding number for the function they wish to use. (1- Vacuum, 4- Fragrance, 7- Shampoo) The timer will now display the minimum turn-on price for that function and activate it. (See Figures III-7 & III-8)

INPUTTING USE CODE AT THE VACUUMS

Note:
 For vacuum operations, the operator has the choice of selecting a minimum turn-on price and a maximum turn-off price

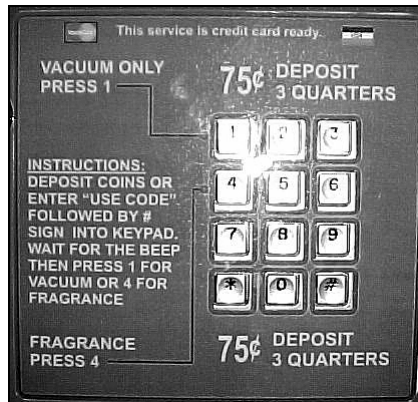

Figure III-6



Figure III-7

Example:

1. If the owner wants the vacuum to turn on at \$.75 and run for 1 cycle, they will set the minimum to be \$.75 and the maximum to be \$.75.
2. If the owner wants the vacuum to turn on at \$.75 and run until the maximum of \$5.00, they will set the minimum to be \$.75 and the maximum to be \$5.00. (Note: Under example #2 the timer will increment in \$.25 increments following the initial turn-on price of \$.75 until it reaches a maximum of \$5.00.)

Once the selected cycle is completed the user will be billed the used amount of that function. The user can re-input their use code and start another transaction while still at the vacuum, however they will encounter another minimum turn-on cost and the display will start over, indicating another transaction.

Returning to the SNC for a printed receipt inputting their use code:

After the user has completed their use of the bays or vacuums, they will return to the SNC for a printed receipt. The user's use code can be put in at the SNC keypad regardless of the state of the SNC. When the user returns to the SNC to receive a printed receipt, they will input their 4-digit use code, followed by the pound key using the keypad on front of the SNC cabinet. Each time the user pushes a number on the keypad, while inputting their code; it will beep, providing positive feedback. Upon completion of an approved use, code the SNC will then announce *"Thank you for visiting the car wash, please take your receipt and come again"*. At this time, the SNC will begin to print a receipt. (Fig.9). Taking their receipt completes the use of the SNC and cancels the use code until another card swipe at the SNC is approved. (See Fig. III-10 for explanation of receipt.)



Fig. III-8

PRINTED RECEIPT

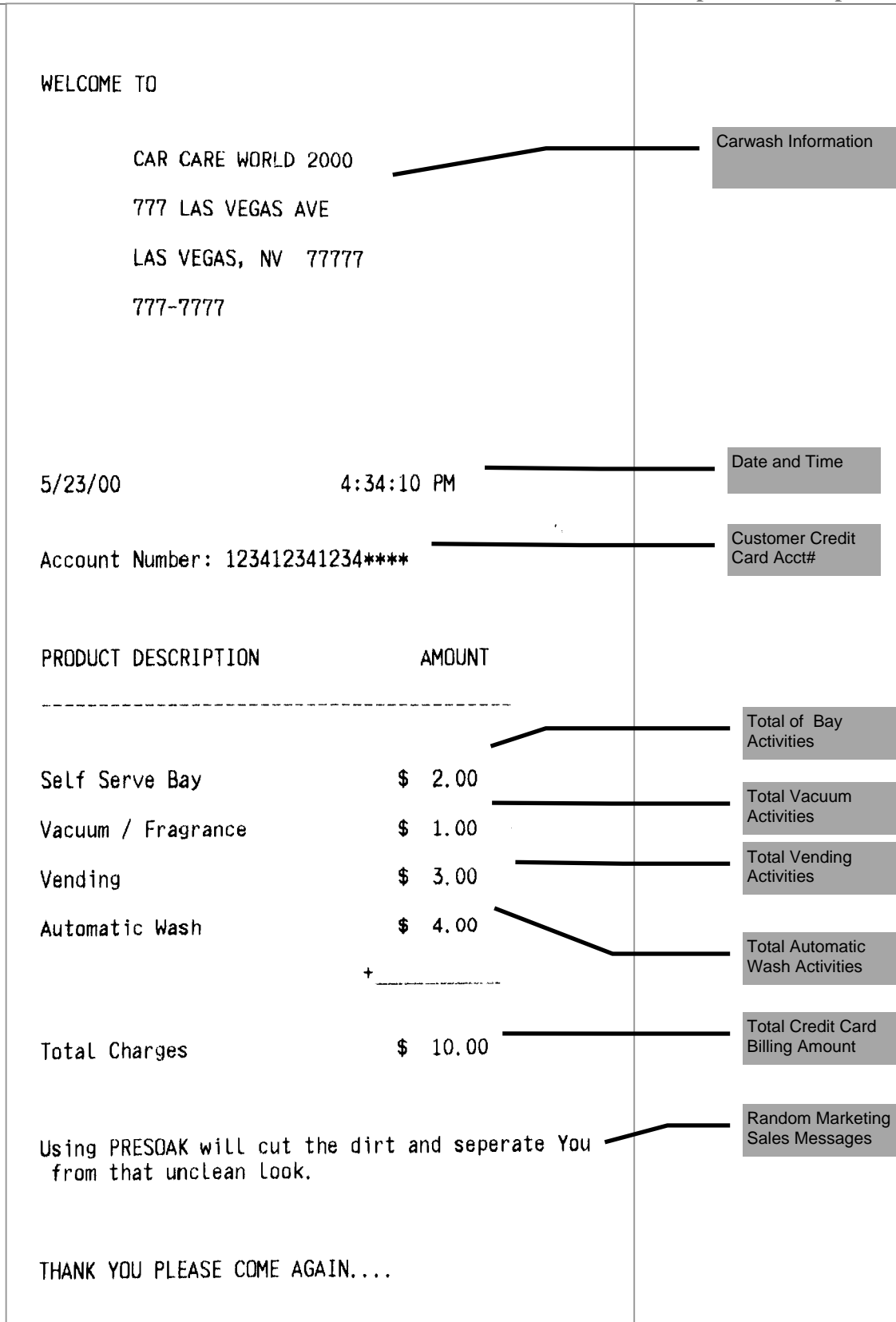

Fig. III-9

SPECIAL ACTIONS THAT WILL HAPPEN:

The user use code is valid only 60 minutes from the completion of the last transaction or until a total amount of billing reaches \$20.00. The user can complete multiple transactions as long as one of the items mentioned above is not exceeded.

A use code may be used by more than one person. (***This setup is not recommended and must be requested by the owner.***) It is recommended that only one device be allowed to be in operation at a time; so that, in the event that any attempt is made using the existing use code more than once, the first use code function is canceled and the second one takes on a new transaction.

***Example:** If a user is using a use code in a bay to wash their vehicle and tells the code to another individual to use at another function such as vacuum, when the second individual inputs the use code the first person's function is canceled.*

The same scenario is true if an individual goes to the SNC and inputs their use code to receive a receipt, any other user of that use code will be canceled.

The above information is intended to help you, the operator, better understand the operation of the SNC and allow you to inform your customers on its proper use.



PRE-PLANNING STEPS

The following steps must occur to ensure a successful installation and turn-on of the SNC. Please check off each item indicating that it has been done to completion:

- Site plans sent to Jim Coleman Company for discussion and review and returned.
- SNC cabinet location identified and prepared to accept SNC cabinet.
- Underground, overhead, wiring (2 Conductor/Shielded) pulled.
- Bay wiring terminated at the Select N Touch meter and SNC.
- Vacuum wiring terminated at the Vacuums and SNC.
- Phone line pulled to the SNC and terminated.
- Power (110 VAC) available to SNC.
- Merchant Number application completed and received.

INSTALLATION

Please read this whole section prior to starting installation. The steps are critical to a successful installation of the SNC.

Cabinet Installation

The following drawing is a typical cabinet pattern for mounting.

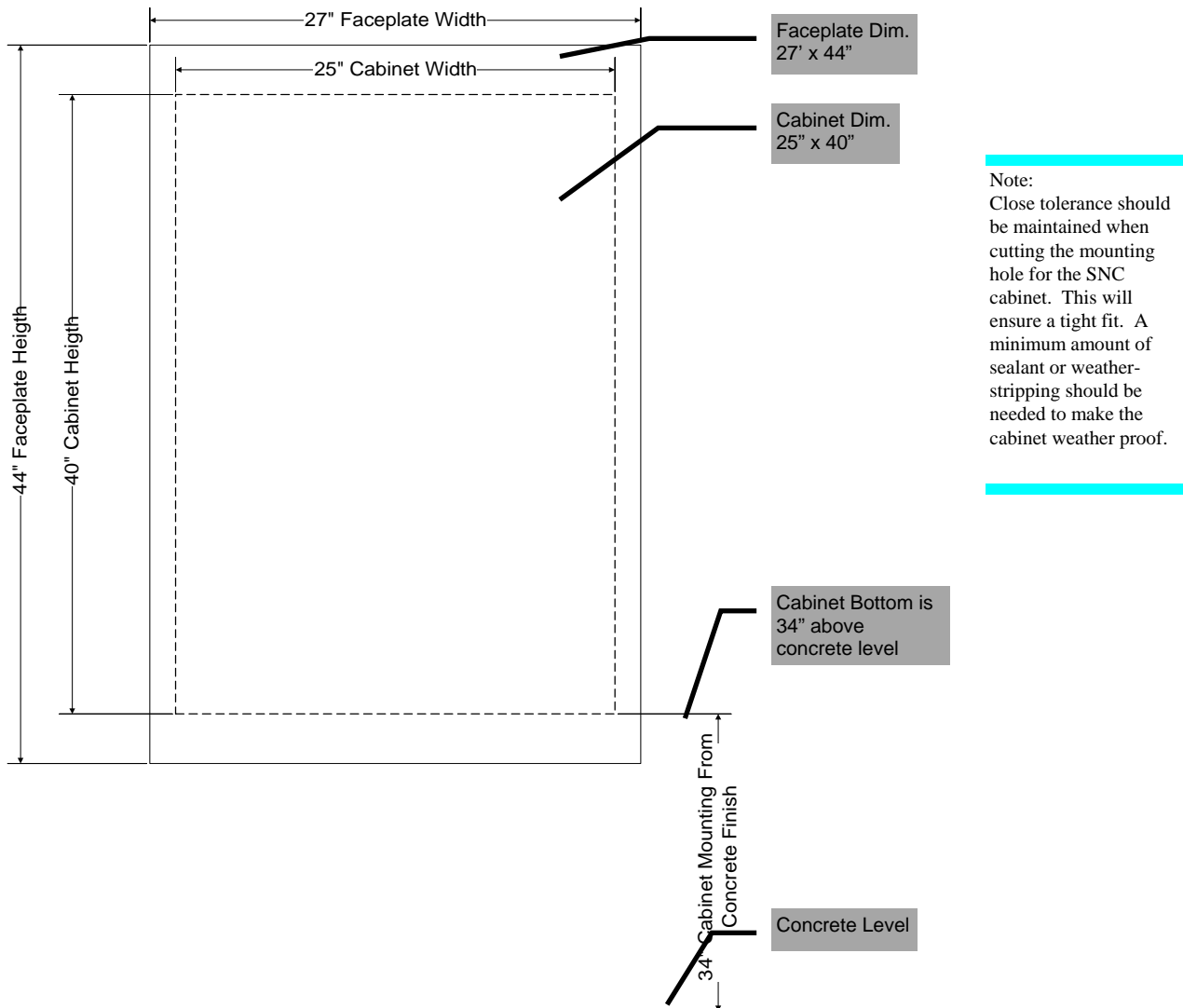

Figure 1

1. After cutting a hole in the wall for the SNC cabinet, insert cabinet into the wall from the front.
2. Once cabinet is inserted in the hole - secure using the angle mounting brackets and bolts provided. (See Fig. 2)

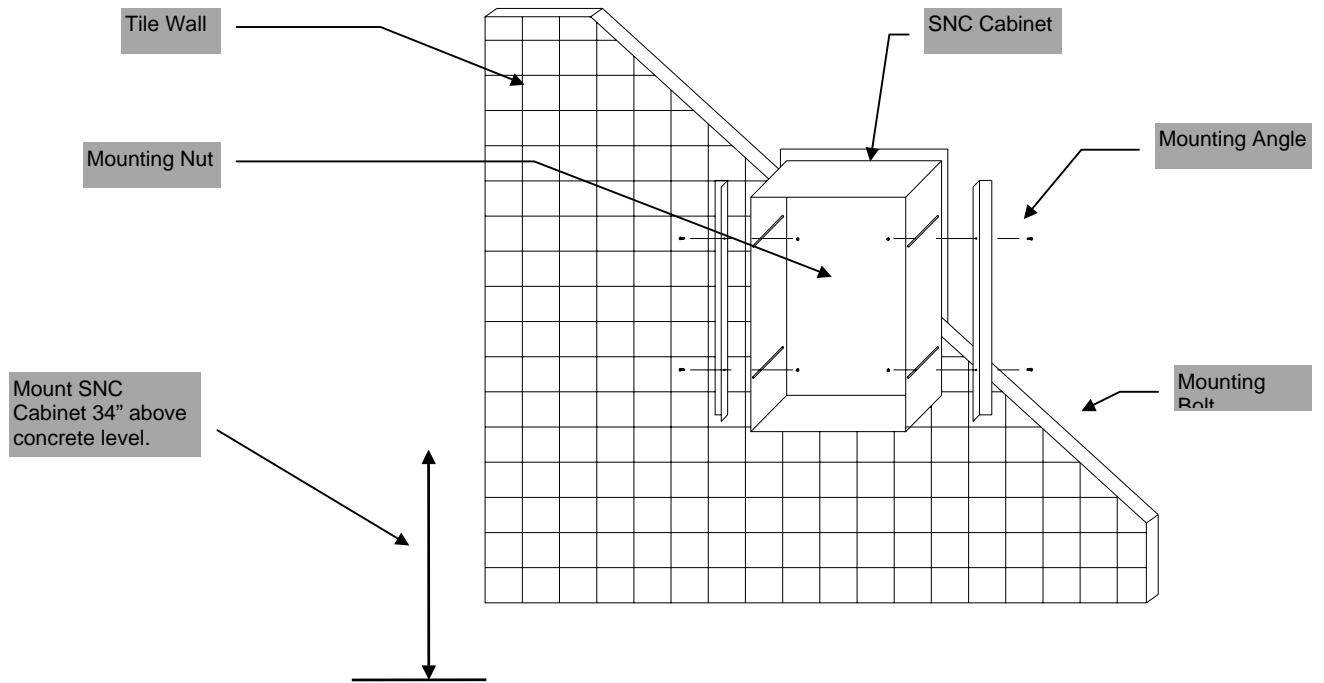

Figure 2

Electrical

SNC Cabinet

1. Connect the SNC to a conditioned, backup power supply of 110 VAC. The reason for a backup is to protect the electronics and other components from spikes and surges associated with power sources.

Phone Line

1. The SNC has two modems installed. One modem is used to call the Credit Card Processor (CCP) for approvals, credits, or settlement. The other modem is for support purposes either from the manufacturer or the operator. (Fig. 3)



Figure 3

2. Dedicated phone lines are recommended from the local provider's termination box to the SNC. One each for both the RAS and the DOD should terminate to each modem for maximum efficiency. The decision to use one phone line configures the DOD as the primary modem used to contact the CCP.

INSTALLATION

- There are two connections on the back of the modem. One is marked line and the other phone. (Fig. 4)

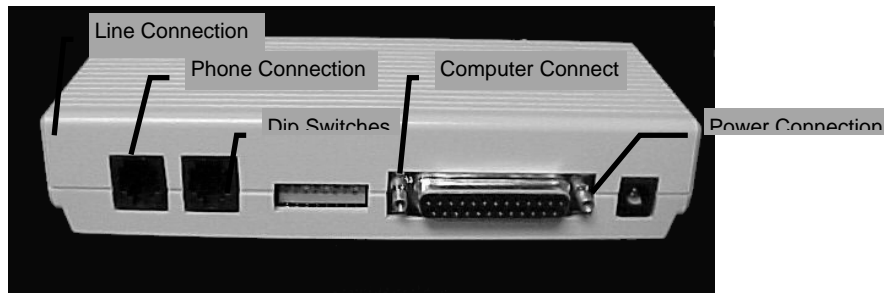

Figure 4

Note:
 If you only have one phone line and in the event that maintenance is being done on the system either from the factory or by the operator the no connections can be made to the CCP. It is suggested that any activity of this type be done off peak hours.

- Terminate the connection of the phone line with a standard RJ11 connector and plug into the line side of the primary modem.



Figure 5

- If a second line is available (**recommended**), you should follow the steps above and terminate it.
- If a second line is not available (**least efficient**) you should have an additional phone line and connect one end of it to the phone side of the primary modem and the other end into the line side of the secondary modem. (Fig. 6)

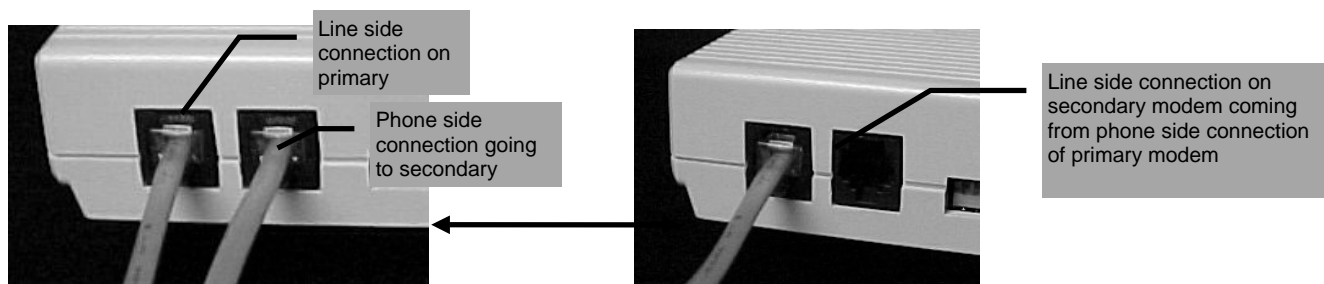

Figure 6

1. Each device connected to the SNC must have a **keypad, push button controller, and timer**. This combination of devices communicates to one another as well as to the SNC.
2. Each combination of devices is connected to the SNC via a communication cable; a 2-conductor, 22 ga. shielded cable (**recommended.**) i.e.; **JCC P/N 40095; Manhattan P/N M39113**
3. On each circuit board there is a RS485 connector. The communication cable attaches these RS485 connectors to the SNC Interface board.
4. The connector for the PBC is located on the board. (See Fig. 7)

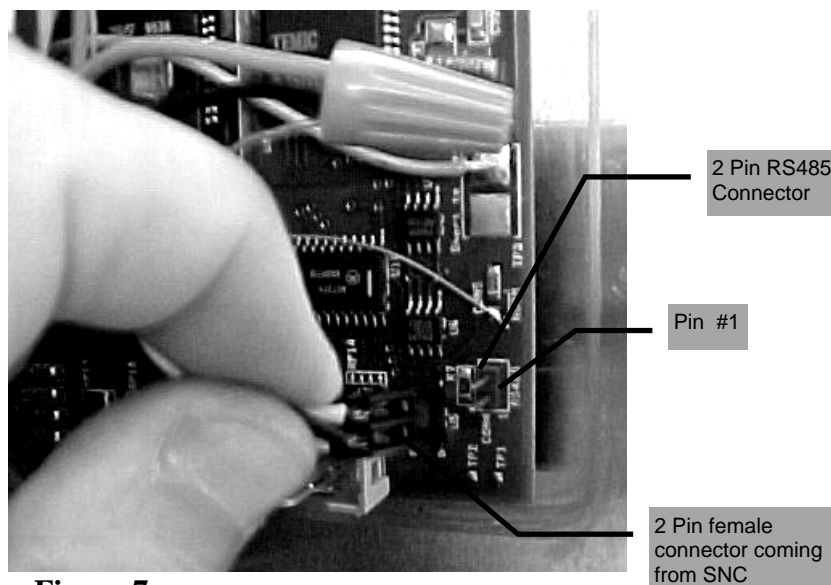

Figure 7

Note: The communication cable cannot be put in the same conduit or trough as power. Electrical leakage will cause the communication to not perform properly.

5. Connect the black wire of the 2-conductor shielded cable to pin #1 on the 2 pin connector. (See Fig. 7) Connect the white (or red) wire to pin #2.
6. Complete this for all devices connecting to the SNC.
7. The timers and the PBC will be connected parallel to each other. Both devices will be communicating to one another.

Bays

1. The PBC and bay timer are located in the bay meter. (See Fig. 8)

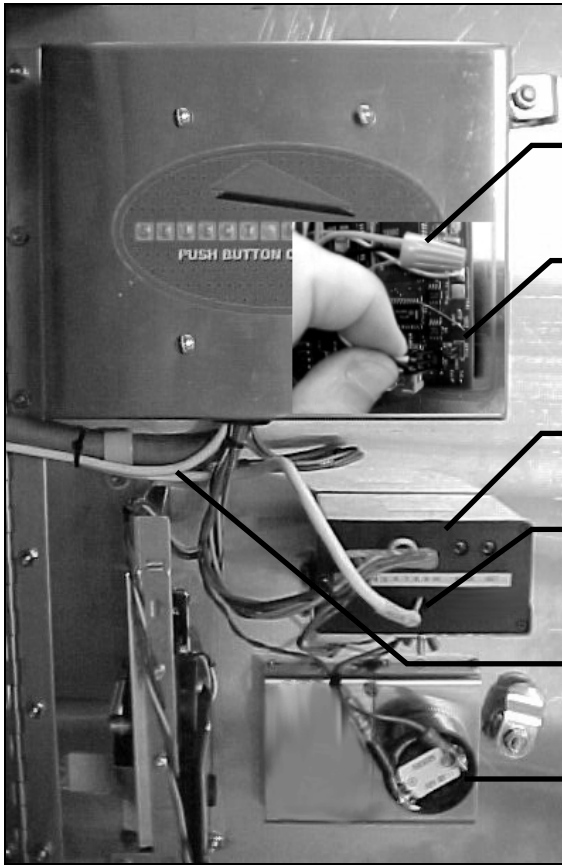

***Figure 8**

Push Button
Controller

RS485
Connector on

Bay Timer

RS485 Connector
from timer to SNC

RS485 Connector
from PBC to SNC

Horn

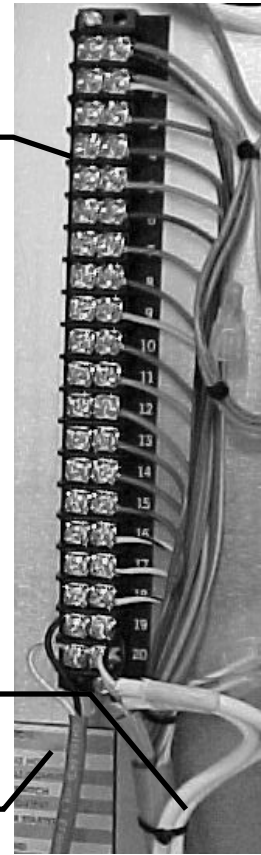

Terminal
Strip

Shielded Cable from
PBC and
Timer

Shielded
Cable from
SNC

Figure 9

2. You will notice that the timer does not have an isolated 2-conductor shielded wire. (See Fig. 8) Its RS485 connection extends from the small 10-position connector and ties to the PBC RS485 before connecting to the 2-conductor shielded communication cable at the terminal strip on the back of the bay meter hull. (See Fig. 9)
3. The horn located in the meter box is used for the last coin alert feature in the timer and also the output from the PBC showing a positive input on the keypad.
4. The two cables coming from the meter door will terminate on the terminal strip located inside the meter box. (See Fig. 9)
5. The other end of the cable located inside of the meter box(s) and coming from the PBC and Timer are terminated at the interface board (See Fig. 7) located in the SNC cabinet using a 3 pin connector using the following connection scheme.(See Fig. 10)

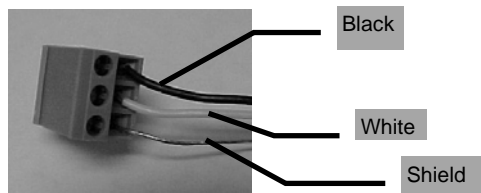
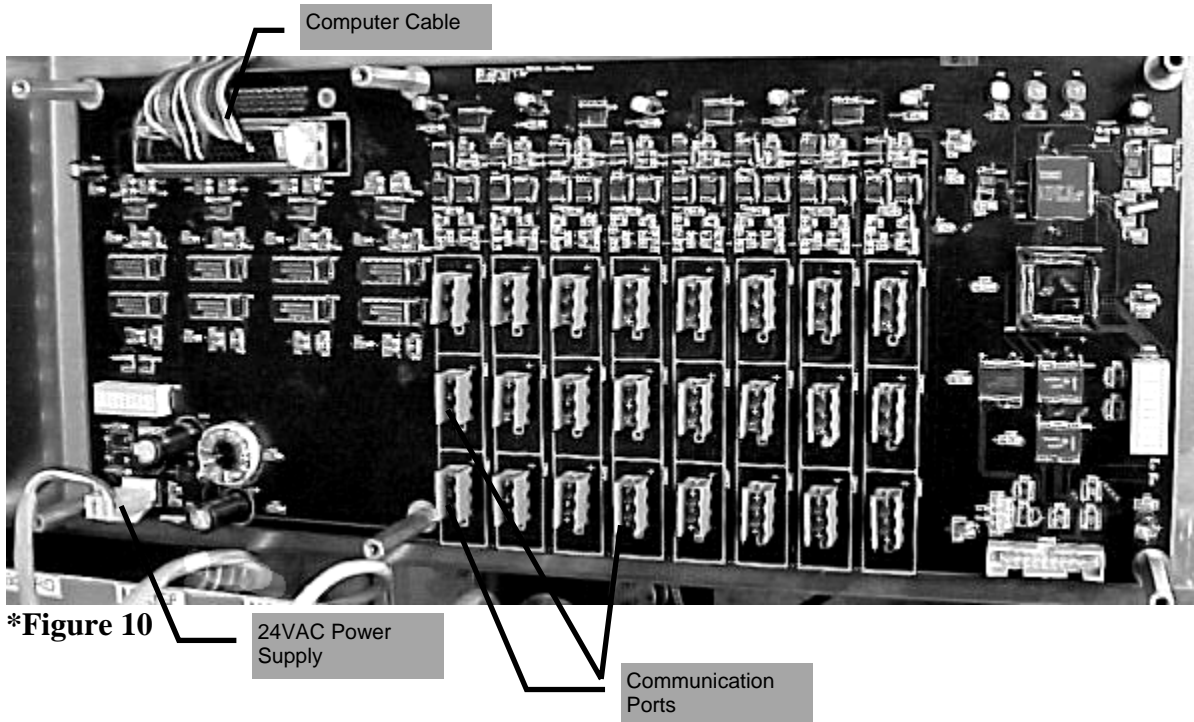
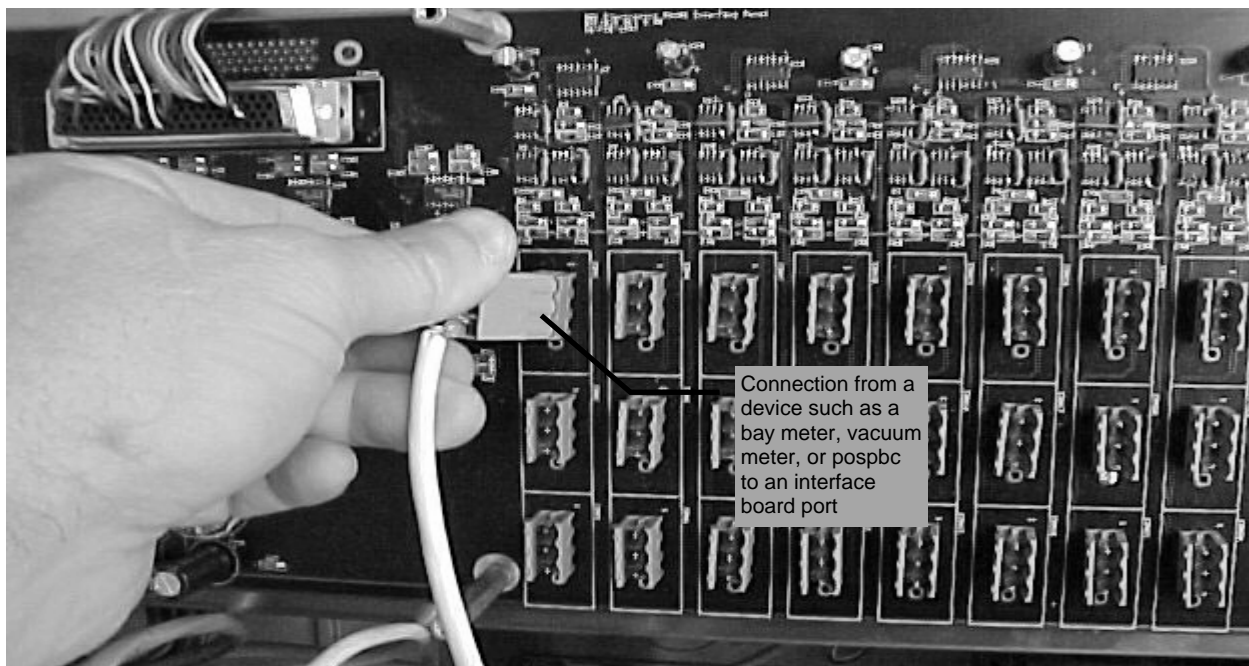

Figure 10. COMMUNICATION CABLES



***Figure 10**



***Figure 11**

6. Connections to the interface board can be made either 1 per port for a single device or up to three devices per port, such as the connections from each bay.
7. Each bay and each vacuum will have 2 devices (bay timer and bay PBC) terminated to the interface board by one connector to only one port.

Vacuums

1. Vacuum connections are made exactly like the bays.
2. Like the bays the vacuums will have a PBC and a timer connected together via RS-485 connections. (See Fig 12)

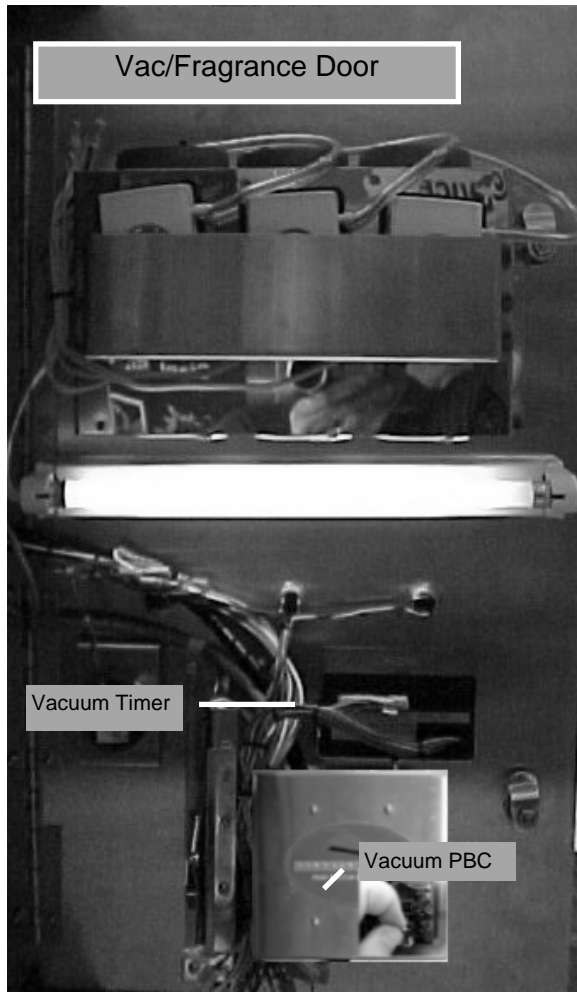

Figure 12

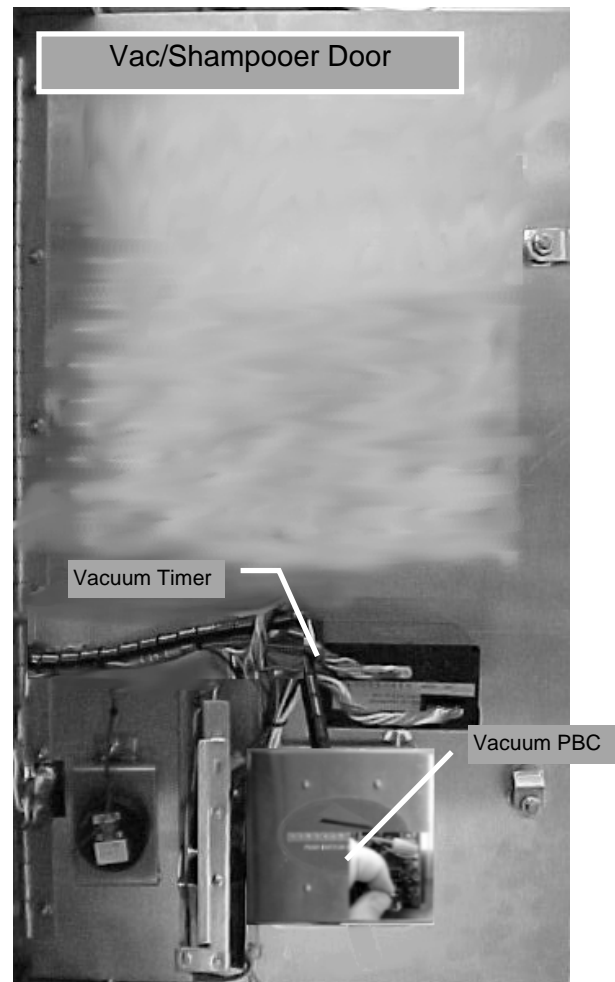

Figure 13

3. The two cables coming from the meter door will terminate on the terminal strip located inside the meter box. (See Fig. 14 and Fig. 15)

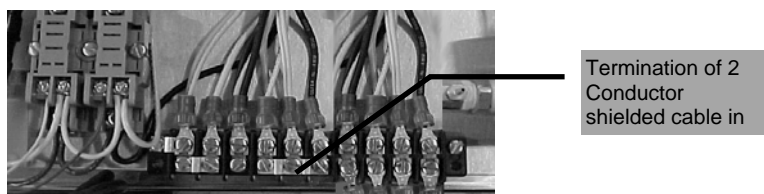

Figure 14

- The other end of the cable located inside of the meter box(s) and coming from the PBC and Timer are terminated at the interface board (See Fig. 11) located in the SNC cabinet using a 3 pin connector using the following connection scheme.(See Fig. 16)

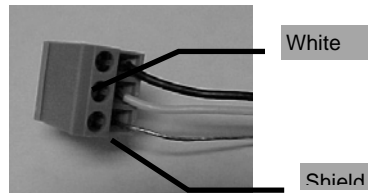

Figure 15

- Connections to the interface board can be made either 1 per port for a single device or up to three devices per port, such as the connections from each vacuum.
- Each vacuum will have 2 devices (vac timer and vac PBC) terminated to the interface board.

Installation Completion

Printer Maintenance

- The only device that the operator will have to assist in is the receipt printer.
- The receipt printer is used to print the user receipts as well as the operator reports.
- Below are the items required for the printer. (See Fig. 17)

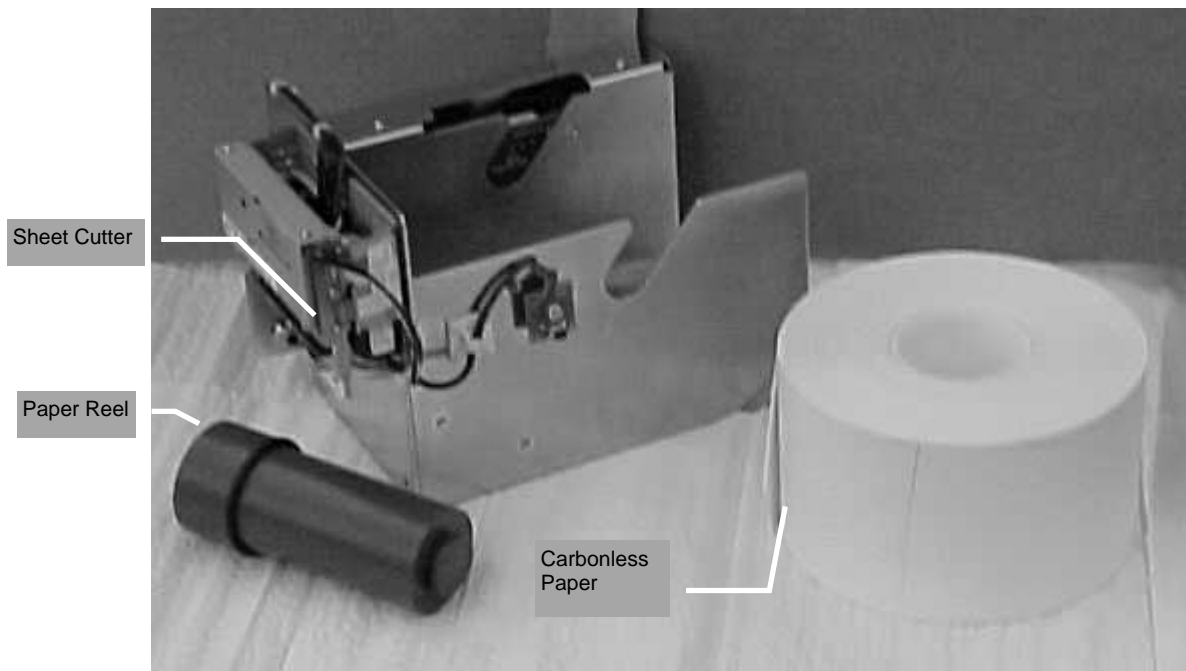

Figure 16

PRINTER MAINTENANCE

4. The printer is located on the right hand side of the SNC cabinet. (See Fig. 2 in the Component Section of this manual)
5. Unlatch cabinet door latches and let door open.
6. Turn off the power on the printer control panel and paper advance (See Fig. 18)

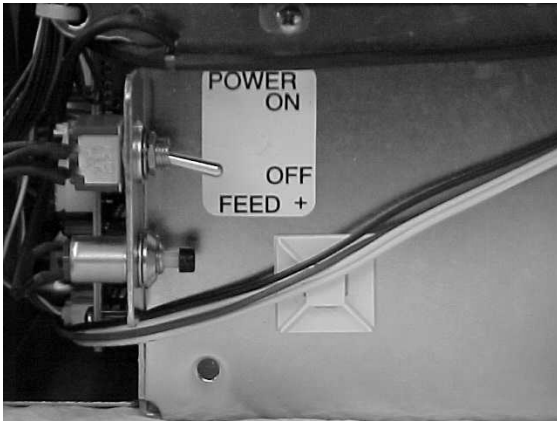

Figure 17

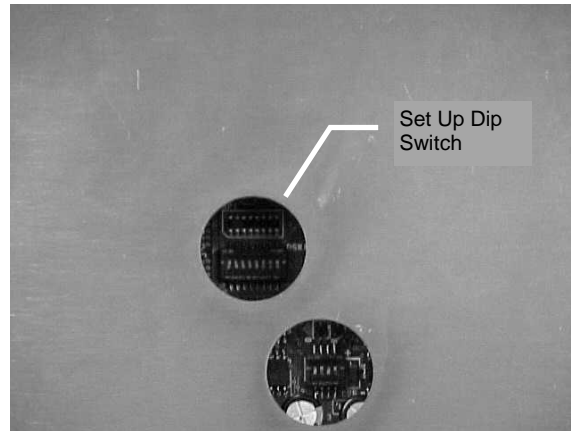
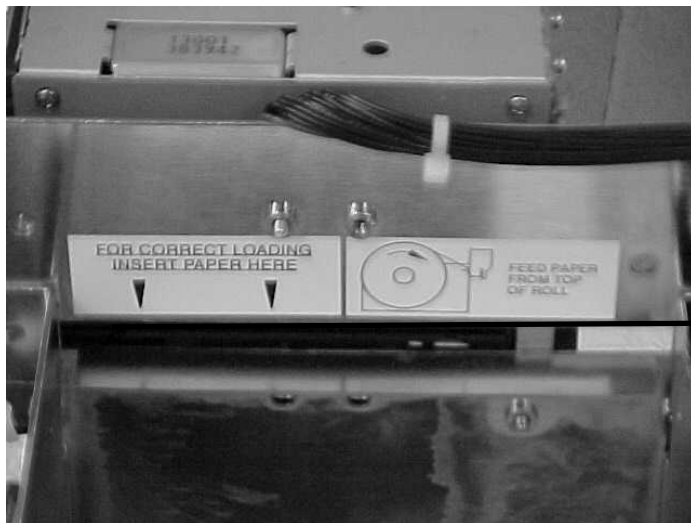

Figure 18

Installing Paper

1. Study routing guide in Fig 20. and the following pictures on a step by step manner.
2. Paper installation can be a challenge on the first attempt, but will be quickly learned.



Insert Paper here with the paper feeding from the top of the roll

Figure 19

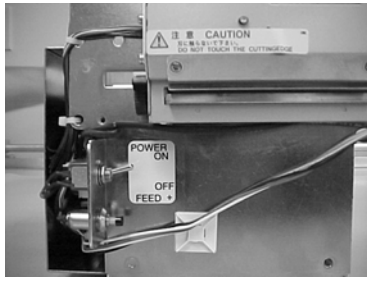

Step 1.

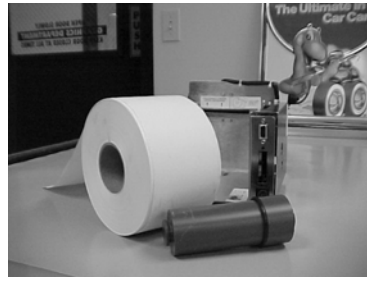

Step 2.

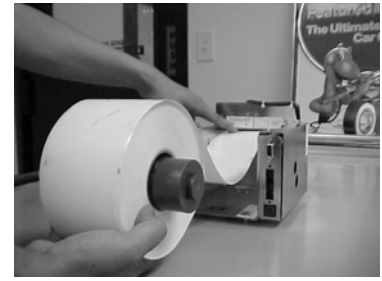

Step 3.

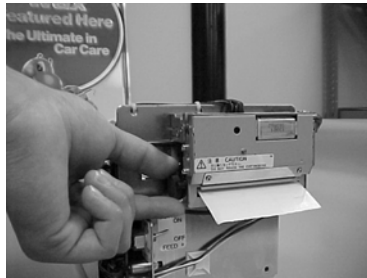

Step 4.

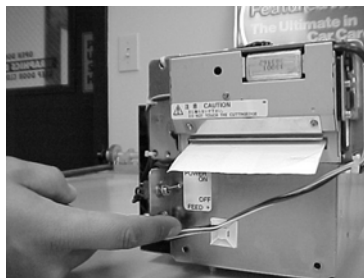

Step 5.

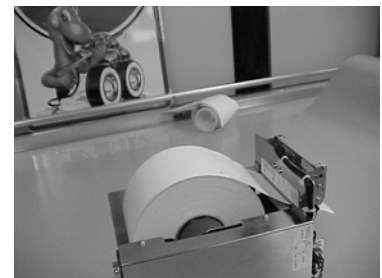

Step 6.



Step 7.

- Step 1 Open Front of SNC Cabinet to access power on and paper feed control switches.
- Step 2 Remove old paper spool from paper cylinder
- Step 3 Insert paper cylinder through spool of new roll of paper with excess to right of spool as paper Feeds over the top
- Step 4 Use clutch knob to begin paper feed
- Step 5 Ensure paper is properly aligned using paper feed switch to tighten excess on spool
- Step 6 Verify paper feeds from the top of roll
- Step 7 Verify cylinder excess is to the right when view paper from rear of printer

Electronic Vendor Island Installation and Turn On

Materials:

- 1 Stainless steel electronic vendor base with vendor meter assembly.
- 2 3 – conductor cable (18 – 22 AWG) stranded unshielded 30°C
- 3 2 – conductor cable (22 AWG) stranded w/shielded ground 300 V 30°C [If you are using a Swipe N Clean system].
- 4 24 VAC power source, usually provided by the Super Saver Control Transformer.
- 5 3 – 6 fork terminal crimp leads

Procedure:

Functional Overview:

During construction ensure that provisions are made to bring 24 VAC to the Input connection on the leftmost terminal strip housed on the back wall within the vendor meter hull. [Labeled 24 Volts AC ONLY]

*** If you have a Swipe N Clean system ensure provisions to connect the 2 – conductor cable w/shielded ground between the vendor meter hull and the Swipe N Clean cabinet are completed.

Be sure to fuse the hot leg of the 24 VAC input power between the source and the terminal strip with a 5 ampere 125V fuse.

The JCC company typically crimps the leads of stranded cables with fork connectors to increase the integrity of the connection over time. This procedure is recommended but not required.

Connect the leads from the 24 VAC source to the three leads on the terminal strip located on the leftmost back wall of the vendor meter hull as labeled.

*** If you have a Swipe N Clean system run the 2 – conductor cable w/shielded ground between the vendor meter hull and the Swipe N Clean cabinet. Connect the vendor meter hull to the leftmost terminal strip on the connections labeled [COMMUNICATION CABLE ONLY] and the Swipe N Clean end to the 1035 interface board using a three position phoenix connector provided.

Canister Installation:

Each canister is mounted on the stainless steel vendor island frame with self tapping stainless steel screws in designated locations as marked from the factory. The order of canister installation for individual products is determined by their rotation on the face of the meter door.

The rotation starts from the 12:00 o'clock position of the keypad and proceeds clockwise through ten positions. Traveling around the outside of the keypad the number two key is the first position. Count clockwise to the number one key which will be the tenth position.

Vendor islands that are winged number the first canister to the far left of the vendor meter assembly and continues in order from left to right on the island. See diagram.

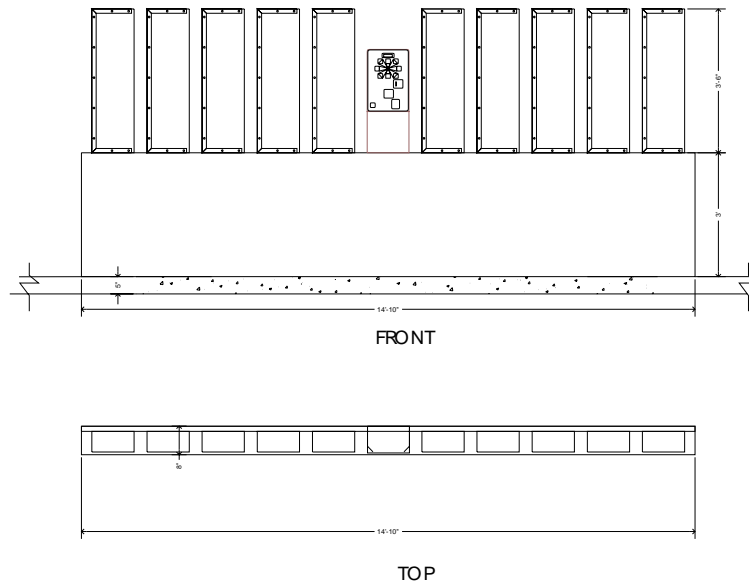

1. Vendor islands that are perpendicular and have their canisters back to back start their numbering at the leftmost canister nearest vendor meter and continues in order to the last vendor on the left side then the next vendor starts again in the front on the right side and continues to the right rear. See diagram.

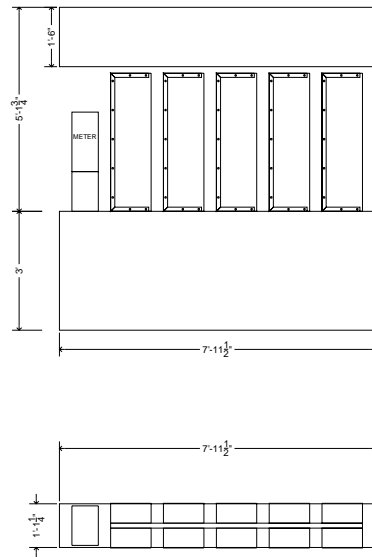

2. Vendors that are essentially round in construction; i.e., octagons and hexagons start their numbering at the first canister to the right of the vendor meter and continue counter-clockwise around the vendor. **[The maximum number of canisters any vendor meter can accommodate is ten; islands with more than ten positions require two or more vendor meters.]**

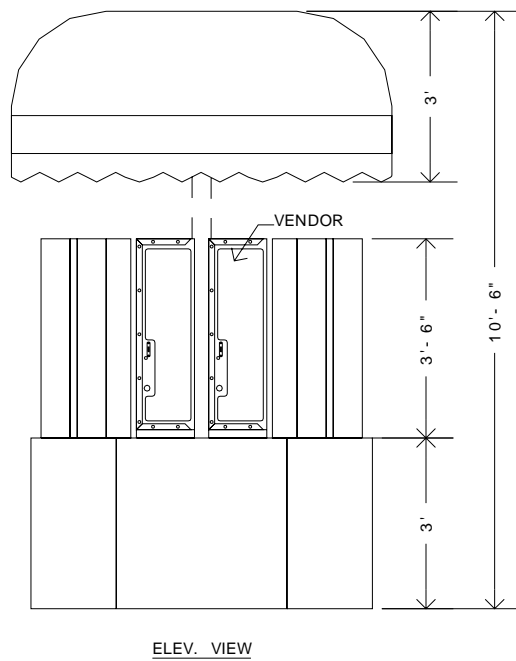
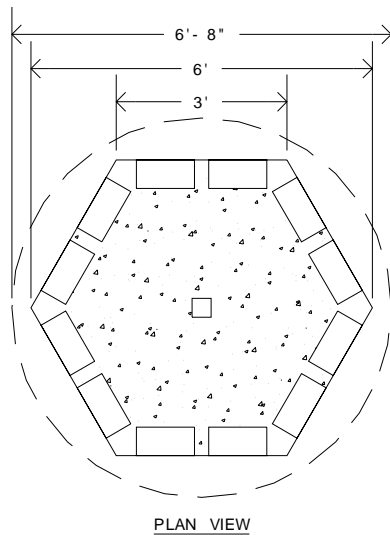

3. Islands with less than ten position will have multiple keys jumpered together to fill out the design of the meter decal. These jumpers are established at the wiring level of the meter hull and will vary according to each island layout.

Each vend position should come wired, numbered and labeled with the appropriated product to be placed there.

Product pricing is preset at the factory according to the customers original order but prices are always programmable whenever the decision to do so is made. Programming instructions are available by request and can be found in the manual for the latest version of the Swipe N Clean manual.

VENDOR PRICING PROGRAM

Located on the lower middle of the control board is a small white push button switch. You will need to remove the cover to access it. Press and hold the switch until the light above keypad button [2] is on. The price will now display on the timer. Press the keypad button [8] to increment the price and the keypad button [0] to decrement the price for vendor 1. Press the keypad button 5 to advance to vendor 2. Continue around the keypad until all prices are set. Return to the button [2] keypad position and press [#] to return to normal mode.

PROGRAMMING INSTRUCTIONS - 1034 TIMER

Introduction & Wiring Schedule - (Note: See end of this section for a Menu Chart)

Following is information regarding the Swipe-N-Clean CT1034 Timer installation.

In order to avoid any confusion, the following is a print out of the 1034 Timer:

1:	Not Used	(**Purple)
2:	Quarter Input	Orange/Black
3:	Horn (-)	Green/Black
4:	Horn (+)	Red/Black
5:	Safety Ground	Lime (*Green)
6:	24 V Timed Output to Switch	Blue/Black
7.	Token Input	Red/Yellow (*Yellow)
8.	Not Used	
9:	24V Common	Green
10:	24V Hot	Orange

** Old Harness
* New Harness

Programming Instructions:

- Flashing 00:00 (or last programmed price) should scroll when timer is powered. **Depress Mode Switch** and hold until the word "Menu" appears. **Release the mode switch**
- Depress the mode switch, **once again** and the "A" menu will appear: **A:01**
The "A" menu controls the number of quarters needed to start the timer.
 - Depress the set switch;** located on the back of the timer, to increase the number up to a maximum of 20 quarters.
- Depress the mode switch once again, the "B" menu will appear: B:00**
The "B" menu controls the number of seconds that the timer will operate. For example, for the wash to start with 3 minutes and 30 seconds enter 30 at this menu. Leave at :00 for minutes only.
 - Depress the set switch** to advance the number. You may enter up to 59. **Note:** *the seconds shown will remain on the display until you have completed the "C" menu.*
- Depress the mode switch once again, the "C" menu will appear: C0:00**
The "C" menu controls the number of minutes that the timer will run.
 - Depress the set switch** to advance the number. You may enter up to 99. **Note:** *the minutes and seconds now appear on the display.*
- Depress the mode switch once again, the "D" menu will appear: D:00**
The "D" menu controls the number of seconds that the horn will sound when one minute remains on the timer.
 - Depress the set switch to advance the number.** You may enter up to 59.
 - if you do not enter a number at this time, the horn will not sound.
- Depress mode switch again** and "H" menu will appear **H0:00**
The "H" menu tells the amount of time each additional quarter will purchase. The timer sets automatic by dividing time set on "C" menu by number of coins on "A" menu. *(If these settings are for the second function go to instruction #12)*
- Depress mode switch** to display the function mode: *The timer is being programmed for what purpose?* to display the following choices. Press the set button to scroll through all the functions - **depress mode** when desired function has been selected.

PROGRAMMING INSTRUCTIONS - 1034 TIMER

WASH	Bay	VAC	Regular Vacuum
RUN	Not Used		
USE	Not Used		
DRY	Not Used	FVAC	Combination Fragrance/Vac Unit
PLAY	Not Used	SVAC	Combination Shampoo/Vac Unit

8. **Depress mode switch again**, and the “P” menu will appear: **P:11**
 The “P” menu displays the address setting for the PBC board used in combination with this timer.
 • Depress set switch to advance to the desired number. Holding the set switch will continuously advance the numbers.
 • See Chart to determine what address to set in “P”.
9. **Depress the mode switch again**, the “T” menu will appear: **T:21** (the “T” menu displays the address setting for the timer used in combination with its PBC board).
 • Depress the set switch to advance to the desired number, holding the set switch will continuously advance the number
 • See Chart to determine what address to set in “T”

“P” Chart Wash Bays									
	Bay 1	Bay 2	Bay 3	Bay 4	Bay 5	Bay 6	Bay 7	Bay 8	Bay 9
Wash Bay PBC Board	11	12	13	14	15	16	17	18	19
	Bay 10	Bay 11	Bay 12	Bay 13	Bay 14	Bay 15	Bay 16	Bay 17	Bay 18
Wash Bay PBC Board	61	62	63	64	65	66	67	68	69
“P” Chart Vacuums									
	Vac 1	Vac 2	Vac 3	Vac 4	Vac 5	Vac 6	Vac 7	Vac 8	Vac 9
Vac PBC Board	31	32	33	34	35	36	37	38	39
	Vac 10	Vac 11	Vac 12	Vac 13	Vac 14	Vac 15	Vac 16	Vac 17	Vac 18
Vac PBC Board	81	82	83	84	85	86	87	88	89
“P” Chart Vendor									
	Vendor 1		Vendor 2		Vendor 3		Vendor 4		
Vendor PBC Board	51		53		55		57		

“T” Chart Wash Bays									
	Bay 1	Bay 2	Bay 3	Bay 4	Bay 5	Bay 6	Bay 7	Bay 8	Bay 9
Wash Bay Timer	21	22	23	24	25	26	27	28	29
	Bay 10	Bay 11	Bay 12	Bay 13	Bay 14	Bay 15	Bay 16	Bay 17	Bay 18
Wash Bay Timer	71	72	73	74	75	76	77	78	79
“T” Chart Vacuums									
	Vac 1	Vac 2	Vac 3	Vac 4	Vac 5	Vac 6	Vac 7	Vac 8	Vac 9
Vac Timer	41	42	43	44	45	46	47	48	49
	Vac 10	Vac 11	Vac 12	Vac 13	Vac 14	Vac 15	Vac 16	Vac 17	Vac 18
Vac Timer	91	92	93	94	95	96	97	98	99
“T” Chart Vendor									
	Vendor 1		Vendor 2		Vendor 3		Vendor 4		
Vendor PBC Board	52		54		56		58		

PROGRAMMING INSTRUCTIONS - 1034 TIMER

WHEN PROGRAMMING COMBINATION UNITS ALWAYS PROGRAM THE VAC SELECTION FIRST AND THEN PROGRAM THE FRAGRANCE OR SHAMPOO SELECTION.

10. **Depress mode switch again.** If non-combination vacuum - **this ends your programming** and timer will go blank if not connected to SNC Computer. It will return to normal operation after approximately 13 seconds. It will operate as a normal coin-operated/token operated timer.

Continue if timer used for combination vacuums. Depressing mode switch the second "A" menu will appear follow instructions 2 through 6 above.

12. **Depress the mode switch again** if not a shampoo/vac **this ends your programming session** as in 10 above.

13. If shampoo/vacuum - Depressing mode switch an "A" menu will appear - Set "A":04

- **Depress mode switch** "b" menu will appear, set b:00
- **Depress mode switch** again, "c" menu will appear set c: 4:00
- **Depress mode switch** again, "b" menu will appear set b:00
- **Depress mode switch** again "c" menu will appear set c:1:00
- **Depress mode switch** again **ends programming mode.** See #10.

14. The timer is now ready for operation.

<i>Menus</i>	
<i>Menu</i>	<i>Valid Entries</i>
A: Number of Coins to Start Timer	Valid entries are from 1 to 20 coins to start
B: Number of Seconds of Time	This menu creates some confusion for customers. TYPICALLY THIS NUMBER IS LEFT AT ZERO. The menu is in place for those customers who have a wash that starts at 3:30 (for example). In this case, you would enter the :30 at this point. Valid entries are from :00 to :59.
C: Number of Minutes of Time	Valid entries are from 0 to 9
D: Seconds Warning Horn Beeps	This is the number of times the user would like the warning horn to sound at the one-minute mark. Valid entries are from :00 to :59. If the menu is left at :00, the warning horn is disabled.
H. Amount of Time per Quarter	This is the amount of time allocated for each quarter (for example 1 quarter= 45 seconds.
P: PBC Address	The address the computer uses to recognize unit PBC
T: Timer Address	The address the computer uses to recognize unit timer.



Fig. 1 – Front View of Timer



Fig. 2– Rear View of Timer

PROGRAMMING INSTRUCTIONS PUSH BUTTON CONTROLLER BOARDS (PBC) WASH – VAC – VENDOR

Each PBC needs to be addressed with its designated unit and associated timer for that unit. This is accomplished by using a pattern of LED's to set the location for computer to identify.

The LED's are numbered from S0 TO S9 and are associated with four other LED's: MS, AUX1, AUX2, & RCV

1. Disconnect the only two pin connector usually with a black and white pair of wires from the PBC board (*See diagram of specific boards for location of pins*)
2. Disconnect power cable connector, the 10-pin connector on con1
3. On the keypad depress and hold the **0** key.
4. While holding the **0** key on the keypad reconnect the 10-pin connector to con 1. After the horn sounds release the **0** key on keypad and check the setting of the function LED's
 - ◆ **1030 Wash Bay PBC:** Look 45° to the left of top of the gray plastic keypad connector and make sure the **MS** LED is the only function of the four available that is lit. (*If it is not lit use the **8** key on the keypad to cycle the lights in the group until only the MS light is on*)
 - ◆ **1036 VAC PBC:** (the four light sequence is at the top left upper quarter of the circuit board after the S0-S9 sequence) also, each type of vacuums gets a setting unique to its type i.e.; **VAC: AUX2; SVAC: AUX2; FVAC: AUX1.** Use the **8** Key to scroll to the desired setting.
 - ◆ **1037 VENDOR PBC:** (MS, AUX1, AUX2 lights are not required and are omitted.) Vendors only need to be addressed to communicate w/timers. Go directly to Step #5 after depressing and holding the **0** key "...and the light pattern includes S8..."
5. When the desired setting is verified on the four light sequences – **Depress the **5** key on the keypad once** and the light setting should now switch to a pattern that includes S8 LED being on. This is where the address setting for the PBC board associated with the unit in question is verified. Identify the number of this unit and match the on/off setting from the BAY, VAC, or VENDOR PBC address charts for PBC.
6. When the desired lights have been matched and verified, **Depress the **5** key on the keypad once again** and the light settings should now switch to include the S9 LED being illuminated. This is where the address setting for the timer associated with the unit in question is verified. Identify the number of this unit and match the on/off settings from the BAY, VAC or VENDOR Timer address chart of PBC's.)
7. When the desired lights have been matched and verified, **Depress the **5** key on the keypad to return to the four light sequence** and now it should match the function desired. If all settings are correct, **Depress the **1** key on the keypad** to return to normal operating mode. After approximately 10 seconds running lights should return to PBC and the horn should sound.

GETTING THE PBC AND TIMER TO RECOGNIZE EACH OTHER

8. Remove the power connector from con 1 and communication connector from con 5 or 6 depending on the type of PBC.
9. Timer: Remove power connector and communication connector.
10. Replace power cable then communication cable (observe timer display starts scrolling immediately, 2-4 seconds).

**PROGRAMMING INSTRUCTIONS PUSH BUTTON CONTROLLER BOARDS (PBC)
WASH – VAC – VENDOR**

11. With timer display scrolling – reconnect 2-pin communication cable; make sure the black wire connects to pin 1 *reconnect* 10-pin power cable for PBC (horn should sound and the solenoids S0-S9 should begin to scroll within 2-4 seconds). Pressing keys on the keypad should also activate the horn within 2-4 seconds.

12. When both conditions in 10 and 11 are satisfied and the computer is on and fully connected to the system it can detect the unit and respond to test codes and/or use codes. Enter **123456 plus #** and observe timer display; a return display of bill \$.00 twice is a satisfactory test return. The system should now respond to user codes. *Note: The above test will not function with the vend PBC and vend timer configuration. See Addendum*

WASH BAY – PBC ADDRESSES											
Change S/ light	Toggle Keypad	5	5	7	*	0	#	9	6	3	2
		S9	S8	S7	S6	S5	S4	S3	S2	S1	S0
PBC	11	0	1	0	0	0	0	1	0	1	1
Timer	21	1	0	0	0	0	1	0	1	0	1
2	12	0	1	0	0	0	0	1	1	0	0
	22	1	0	0	0	0	1	0	1	1	0
3	13	0	1	0	0	0	0	1	1	0	1
	23	1	0	0	0	0	1	0	1	1	1
4	14	0	1	0	0	0	0	1	1	1	0
	24	1	0	0	0	0	1	1	0	0	0
5	15	0	1	0	0	0	0	1	1	1	1
	25	1	0	0	0	0	1	1	0	0	1
6	16	0	1	0	0	0	1	0	0	0	0
	26	1	0	0	0	0	1	1	0	1	0
7	17	0	1	0	0	0	1	0	0	0	1
	27	1	0	0	0	0	1	1	0	1	1
8	18	0	1	0	0	0	1	0	0	1	0
	28	1	0	0	0	0	1	1	1	0	0
9	19	0	1	0	0	0	1	0	0	1	1
	29	1	0	0	0	0	1	1	1	0	1
10	61	0	1	0	0	1	1	1	1	0	1
	71	1	0	0	1	0	0	0	1	1	1
11	62	0	1	0	0	1	1	1	1	1	0
	72	1	0	0	1	0	0	1	0	0	0
12	63	0	1	0	0	1	1	1	1	1	1
	73	1	0	0	1	0	0	1	0	0	1
13	64	0	1	0	1	0	0	0	0	0	0
	74	1	0	0	1	0	0	1	0	1	0
14	65	0	1	0	1	0	0	0	0	0	1
	75	1	0	0	1	0	0	1	0	1	1
15	66	0	1	0	1	0	0	0	0	1	0
	76	1	0	0	1	0	0	1	1	0	0
16	67	0	1	0	1	0	0	0	0	1	1
	77	1	0	0	1	0	0	1	1	0	1
17	68	0	1	0	1	0	0	0	1	0	0
	78	1	0	0	1	0	0	1	1	1	0
18	69	0	1	0	1	0	0	0	1	0	1
	79	1	0	0	1	0	0	1	1	1	1

**PROGRAMMING INSTRUCTIONS PUSH BUTTON CONTROLLER BOARDS (PBC)
WASH – VAC – VENDOR**

VAC – PBC ADDRESSES											
To Change S/light	Toggle Keypad Symbol	2	3	6	9	#	0	*	7	5	5
	PBC Timer	S0	S1	S2	S3	S4	S5	S6	S7	S8	S9
1	31	1	1	1	1	1	0	0	0	1	0
	41	1	0	0	1	0	1	0	0	0	1
2	32	0	0	0	0	0	1	0	0	1	0
	42	0	1	0	1	0	1	0	0	0	1
3	33	1	0	0	0	0	1	0	0	1	0
	43	1	1	0	1	0	1	0	0	0	1
4	34	0	1	0	0	0	1	0	0	1	0
	44	0	0	1	1	0	1	0	0	0	1
5	35	1	1	0	0	0	1	0	0	1	0
	45	1	0	1	1	0	1	0	0	0	1
6	36	0	0	1	0	0	1	0	0	1	0
	46	0	1	1	1	0	1	0	0	0	1
7	37	1	0	1	0	0	1	0	0	1	0
	47	1	1	1	1	0	1	0	0	0	1
8	38	0	1	1	0	0	1	0	0	1	0
	48	0	0	0	0	1	1	0	0	0	1
9	39	1	1	1	0	0	1	0	0	1	0
	49	1	0	0	0	1	1	0	0	0	1
10	81	1	0	0	0	1	0	1	0	1	0
	91	1	1	0	1	1	0	1	0	0	1
11	82	0	1	0	0	1	0	1	0	1	0
	92	0	0	1	1	1	0	1	0	0	1
12	83	1	1	0	0	1	0	1	0	1	0
	93	1	0	1	1	1	0	1	0	0	1
13	84	0	0	1	0	1	0	1	0	1	0
	94	0	1	1	1	1	0	1	0	0	1
14	85	1	0	1	0	1	0	1	0	1	0
	95	1	1	1	1	1	0	1	0	0	1
15	86	0	1	1	0	1	0	1	0	1	0
	96	0	0	0	0	0	1	1	0	0	1
16	87	1	1	1	0	1	0	1	0	1	0
	97	1	0	0	0	0	1	1	0	0	1
17	88	0	0	0	1	1	0	1	0	1	0
	98	0	1	0	0	0	1	1	0	0	1
18	89	1	0	0	1	1	0	1	0	1	0
	99	1	1	0	0	0	1	1	0	0	1

VENDOR – PBC ADDRESSES											
Change S/light	Toggle Keypad	5	5	7	*	0	#	9	6	3	2
	PBC Timer	S9	S8	S7	S6	S5	S4	S3	S2	S1	S0
1	51	0	1	0	0	1	1	0	0	1	1
	52	1	0	0	0	1	1	0	1	0	0
2	53	0	1	0	0	1	1	0	1	0	1
	54	1	0	0	0	1	1	0	1	1	0
3	55	0	1	0	0	1	1	0	1	1	1
	56	1	0	0	0	1	1	1	0	0	0
4	57	0	1	0	0	1	1	1	0	0	1
	58	1	0	0	0	1	1	1	0	1	0

KEYPAD PROGRAM KEY

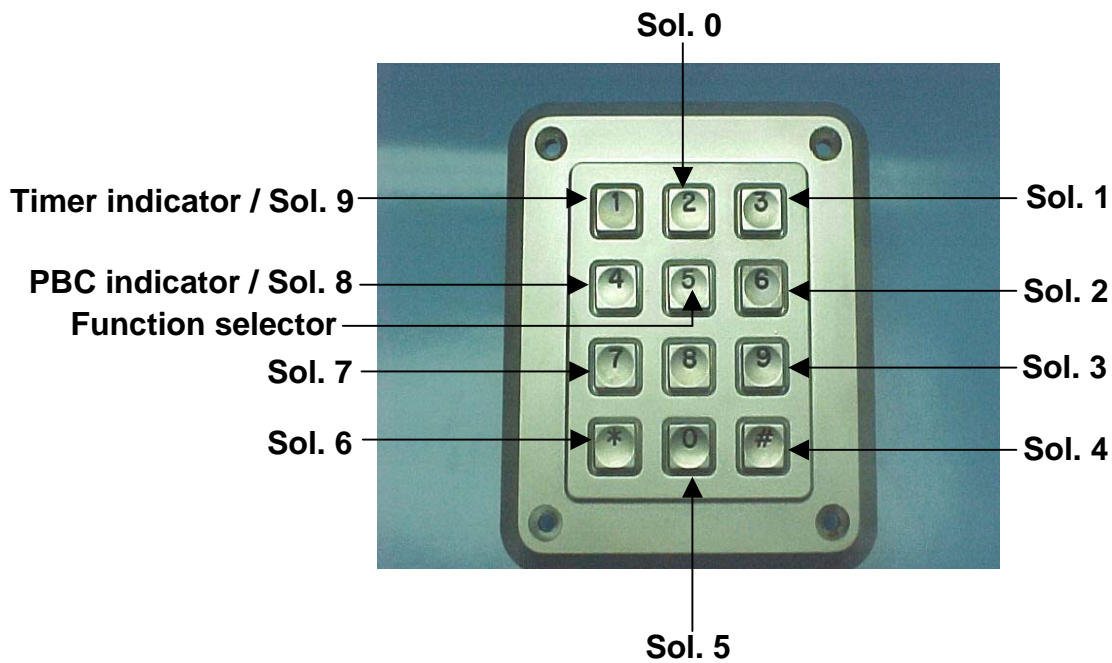

Fig. 2

**OPERATING INSTRUCTIONS PUSH BUTTON CONTROLLER BOARDS (PBC)
WASH BAY – VACUUM – VENDOR**

Keypad operation of the Jim Coleman Company, Inc. Push Button Car Wash Controller

With the Timer Off....

The PBC will light the panel selection LEDs in sequence in a clockwise direction. This light sequence continues without interruption during manipulation of the keypad. Once the user has entered a security Password Sequence then PBC enters a programming mode. The security password is currently 43210# on the BCE 1030 version of the PBC. The intention of the designers has been to make this security password programmable via the RS422 port, but this port is not currently available in the BCE 1030 design. Recommendations on how to set the security password will be taken and implemented. (Currently the security code is programmed at the factory during PBC testing).

Once the PBC has accepted the security password, the Halt LED will display a fast blink. At this point the keypad will respond to three of the keypad keys: “5”, “8” and #. The # key is used to exit the programming mode, pressing this key at any time immediately transfers the PBC back into the idle state where the selection LEDs light in clockwise sequence. The “5” key is used to choose which of the selections is to be programmed (Tire Cleaner, Foaming Wax, etc.). Each time the “5” key is pressed, the selection being programmed changes (rotate around the selection panel in a clockwise direction). The selection being programmed is always indicated by the fast blinking LED. The “8” key is used to choose which of the I/Os which can be enabled when a customer chooses the current panel selection. The three I/Os which are being programmed are the Motor, the Solenoid, and the Auxiliary. Pressing the “8” key will rotate the combinations is as follows: All I/Os are off. All I/Os are on. Motor and Solenoid are on. Motor and Auxiliary are on. Solenoid and Auxiliary are on. Motor alone is on. Solenoid alone is on. Auxiliary alone is on.

In summary: The typical programming sequence for the JCC PBC is as follows:

1. Administrator will enter the security code currently 43210#.
2. If an incorrect sequence is entered, press the # key to reset the PBC and re-enter the security code.
3. Once the security code is recognized, the “STOP” LED will blink quickly.
4. Administrator will press or hold the “5” key until the selection LED which they wish to program is chosen.
5. Administrator will press or hold the “8” key until the combination of I/Os which they wish to have enable during user wash cycles is displayed on the PBC board mounted LEDs.
6. Administrator will repeat using the “5” key to choose the panel selection and the “8” key to choose I/O activity until they are satisfied with the system programming.
7. Administrator will press the “#” key to exit programming mode, reset the system security to the locked state, and return the PBC to its normal idle state.

With the Timer On...

The PBC will light Halt LED on the Selection panel. The user selects the desired wash function by pressing the associated selection panel key. The selection panel LED associated with that function will

light. The I/Os, which the administrator has previously programmed, will be driven active by the PBC and the car wash is active.

When the user wishes to change wash functions, they press the key associated with that function and the system changes state to accommodate (The keypad is debounced so that intentional sabotage of the car wash system is not possible by repeated, quick key selections or by holding down multiple keys).

When the timer runs out the PBC automatically recognizes the loss of 24VAC and resets itself into the idle state where the selection panel LEDs light in sequence.

Document Revision: 1.01 October 7, 1998
Pertinent to PBC Hardware Revision 1.00 of BCE 1030
PBC Software Revision 1.00. of BCE 1030

Push Button Controller Program Instructions

BAY AND VACUUM PBC ADDRESS PROGRAMS

Bay:

Remove 24vac power connector from top left corner of the PBC board.

Press and hold the [0] zero on the keypad, then reconnect the 24vac power connector to the board and then release the [0] zero.

Check the board to ensure the MS light next to the keypad input connector is on.

- a. The [8] eight key on the keypad will cycle the four light until you have the desired position.

When the MS light is the only light on, of the four function lights, press the [5] five on the keypad to proceed to the settings for the timer address.

Check the lights between the two ten position connectors at the top of the board to ensure that SOL 8 is on and then:

- a. Use the address chart in the Swipe N Clean manual to determine which lights should be on for the bay you are addressing.
- b. Use the keypad programming key to determine which key to press to toggle the wanted solenoids.
- c. When the desired solenoids are on press the [5] five key.

Check the lights between the two ten position connectors at the top of the board to ensure that SOL 9 is on and then:

- a. Use the address chart in the Swipe N Clean manual to determine which lights should be on for the bay you are addressing.
- b. Use the keypad programming key to determine which key to press to toggle the wanted solenoids.
- c. When the desired solenoids are on press the [5] five key.

Check to see if the MS light is now on. If not press the [5] five key until MS is the only light on; then press and hold the [1] one key until the horn sounds.

Vacuum:

Turn off 24vac power circuit breaker in the top left corner of the vacuum meter hull.

Press and hold the [0] zero on the keypad, then re-energize the 24vac power circuit breaker then release the [0] zero.

Check the board to ensure the Aux1 or Aux2 light at the top left of the PBC board is on.

- a. The [8] eight key on the keypad will cycle the four light until you have the desired position.

When the correct auxiliary light is on press the [5] five on the keypad to proceed to the settings for the timer address.

Check the lights at the top left corner of the board to ensure that SOL 8 is on and then:

- a. Use the address chart in the Swipe N Clean manual to determine which lights should be on for the vacuum you are addressing.
- b. Use the keypad programming key to determine which key to press to toggle the wanted solenoids.
- d. When the desired solenoids are on press the [5] five key.

Check the lights at the top left corner of the board to ensure that SOL 9 is on and then:

- a. Use the address chart in the Swipe N Clean manual to determine which lights should be on for the bay you are addressing.
- b. Use the keypad programming key to determine which key to press to toggle the wanted solenoids.
- c. When the desired solenoids are on press the [5] five key.

Check to see if the correct auxiliary light is now on. If not press the [5] five key until aux1 or aux2 is the only light on; then press and hold the [1] one key until the horn sounds.

VENDOR PBC ADDRESS

Most vendor will already come programmed from the factory. The sequence is similar to the Bay PBC address programming. See the chart in the SNC manual for the selected solenoids to be on; follow the steps for programming a Bay PBC address.

VENDOR PRICING PROGRAM

Located on the lower middle of the control board is a small white push button switch. You will need to remove the cover to access it. Press and hold the switch until the light above keypad button [2] is on. The price will now display on the timer. Press the keypad button [8] to increment the price and the keypad button [0] to decrement the price for vendor 1. Press the keypad button 5 to advance to vendor 2. Continue around the keypad until all prices are set. Return to the button [2] keypad position and press [#] to return to normal mode.

VENDOR PRICE PROGRAM KEY

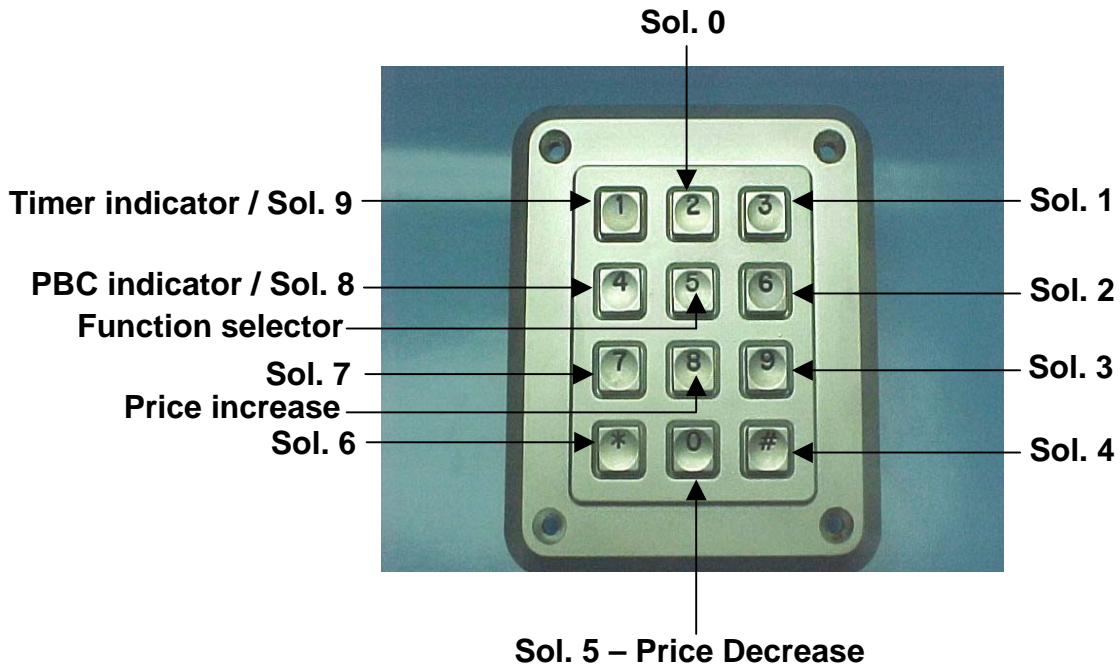

Fig.3

START-UP

System startup is a rather straightforward approach to turning the system on. Ensure that all of the Preplanning steps have been complete and all of the installation steps are done prior to start up.

System

1. Plug power cord from unit into a conditioned power supply that is connected to 110 VAC.
2. Connect the mouse to the auxiliary port (See Fig. 2 in Component Section of this manual) located in the SNC.
3. Connect the keyboard to the auxiliary port located in the SNC.
4. Connect a monitor (not included) to the auxiliary port located in the SNC.
5. Turn-on switch located on power strip (See Fig. 18)
6. The computer will now power up running the SNC software.

IC Verify

IC Verify is the software used to connect you to the credit card processor via telecommunication and your merchant code. It primarily operates unattended; however there is some information you should know and some operations you should be able to perform.

Note:
These operations need to have the auxiliary keyboard, mouse, and monitor connected.

First, we will discuss how to access the IC Verify main screen. Secondly, we will discuss how to manually view and settle transactions; thirdly, we will discuss how to view settlement transaction reports. Lastly, we will discuss how to issue credit to a customer.

Accessing the IC Verify Software

1. While the SNC software is running double click the mouse on the screen.
2. When the Swipe N Clean Utilities screen appears, choose the “*Account Info / exit*” tab.
3. Choose “*Exit Program*” in the bottom right corner of the window, this will return you to the desktop.
4. Choose the ICVerify Icon from the desktop

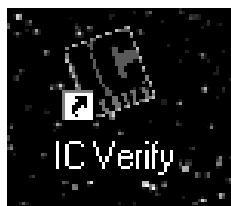

IC VERIFY

5. You will now see the main ICVerify screen. (See Fig. 1)

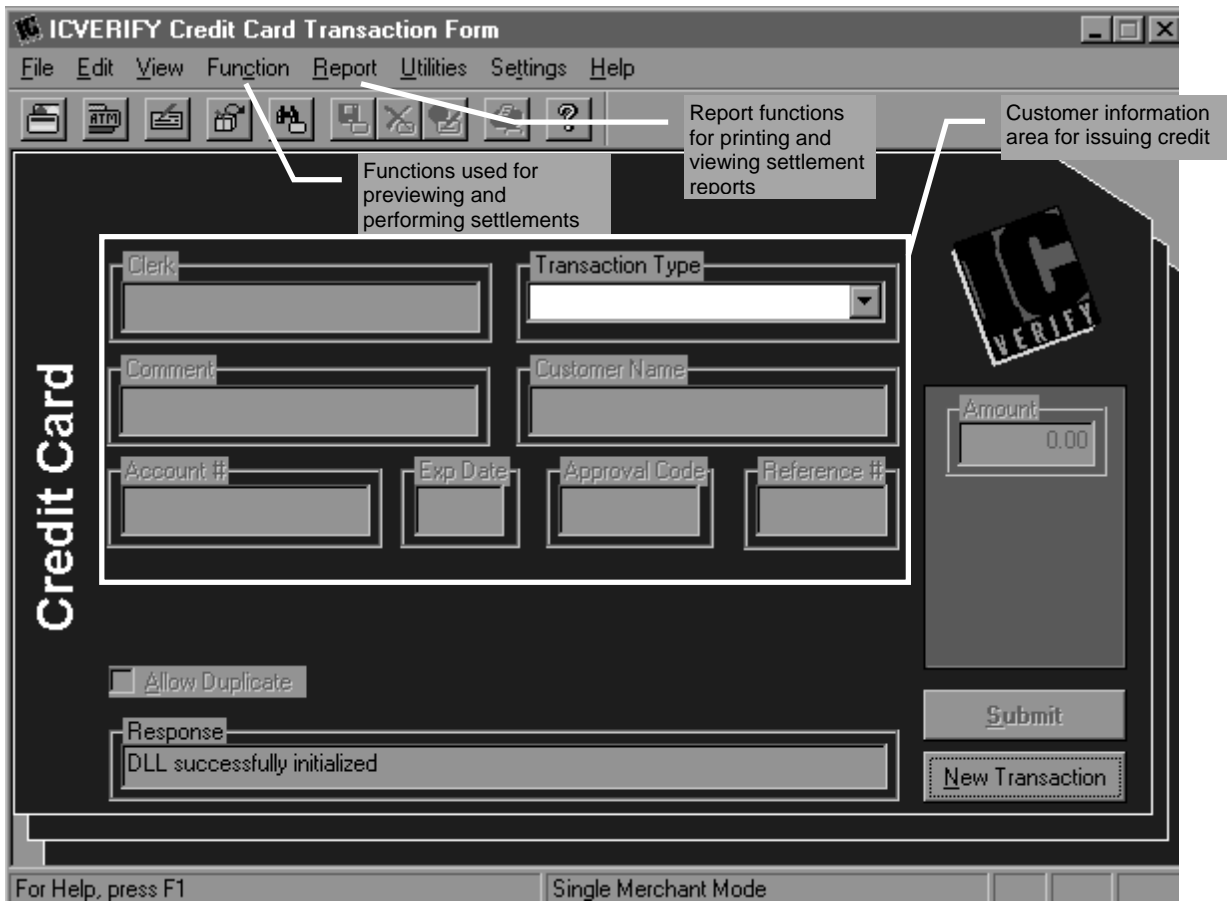

Figure 1

PREVIEWING AND SETTLING TRANSACTIONS

1. Choose the function button on the main screen.

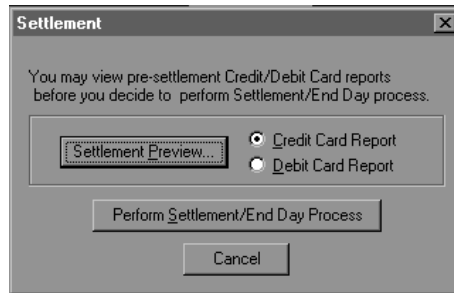

Figure 2

2. Choose the Settlement Preview button to view all current transactions waiting to be settled. If you find any discrepancies make note(s) for further actions.
3. After viewing transactions you may manually perform an “end of day settlement process” or choose “cancel” and return to the main menu.

View Settlement Transaction Reports

1. Choose “Report” option from the main screen.

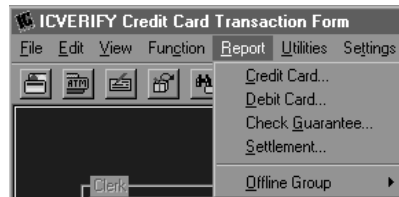

Figure 3

2. Choose “Settlement” option from the pull-down list of options.

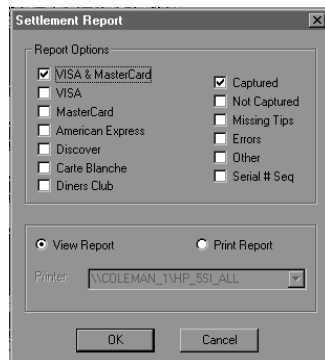

Figure 4

REPORTING

- In the view report screen select “Visa MasterCard” option and press OK.

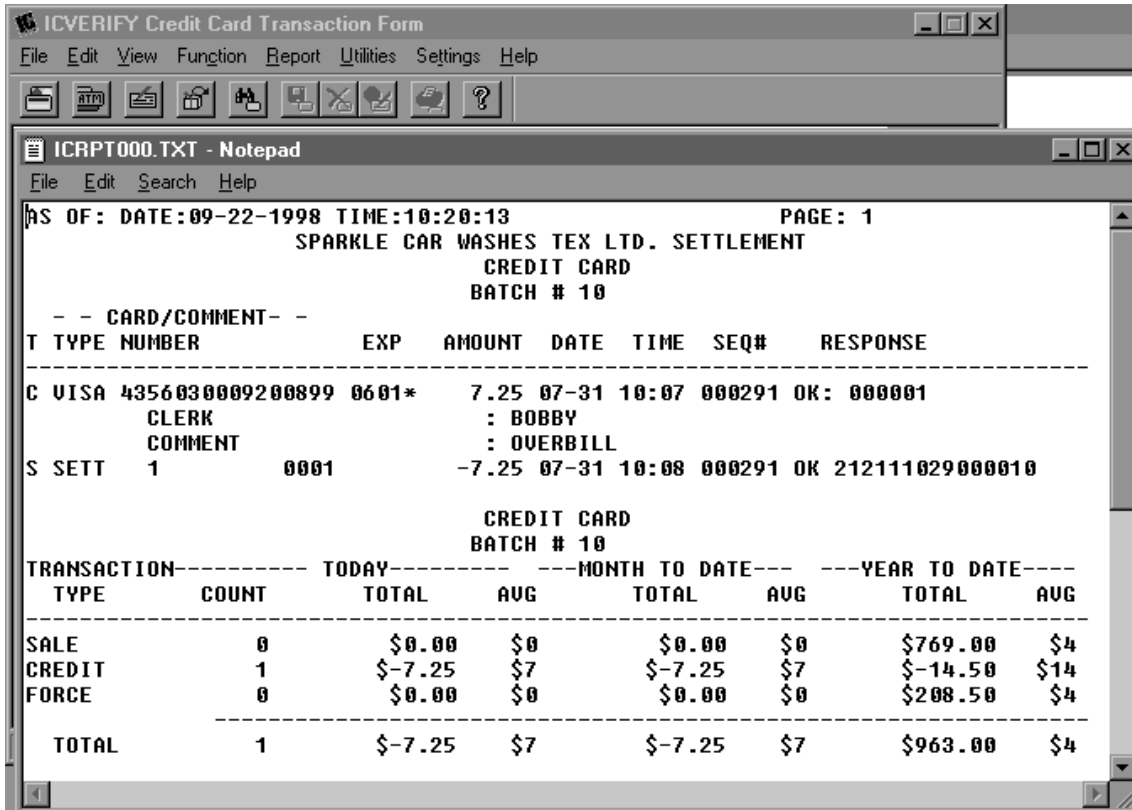

Figure 5

- This report will reflect the totals of the settlement with IC Verify.

1. Issuing credit to a customer is done when either a dispute or incorrect billing was done.
2. Select “New Transaction” option from the main screen.

The screenshot shows a software interface for issuing credit. It features several input fields: 'Clerk', 'Transaction Type' (a dropdown menu with 'Sale' selected), 'Comment', 'Customer Name', 'Account #', and 'Exp Date'. There are also two empty rectangular boxes. On the right side, there is an 'Amount' field with '0.00' entered. At the bottom left, there is a checkbox labeled 'Allow Duplicate' which is unchecked, and a 'Response' text area. At the bottom right, there are two buttons: 'Submit' and 'New Transaction'. The 'IC VERIFY' logo is visible in the top right corner.

Figure 6

3. Fill in each of the fields with the appropriate data on the form.
4. Press submit to submit the transaction.
5. Close the IC Verify program by closing the window.

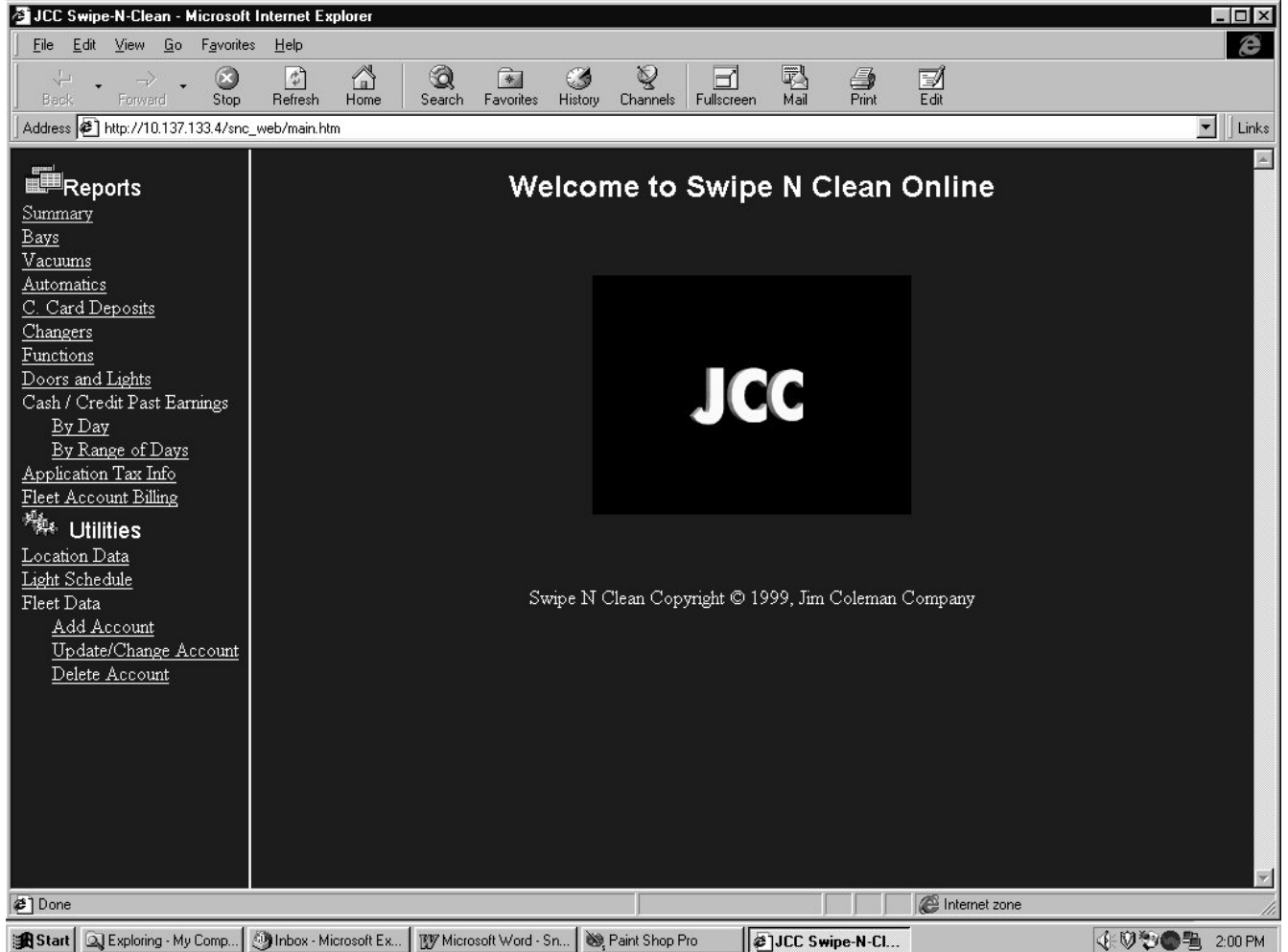

GETTING STARTED WITH SWIPE N CLEAN INCOME MONITORING

Welcome to Jim Coleman Company Swipe N Clean Income Monitoring, a income monitoring and management tool. This system will provide an insight to the self service car wash's, utilizing the Swipe N Clean, cash and credit income. It also has the tools needed to manage some of the day to day operations of the self service car wash.

Its interface is friendly using either Microsoft Internet Explorer 4+ or Netscape 4+. This allows the user the familiar (much like a web site) look to maneuver through the pages and use the data as required.

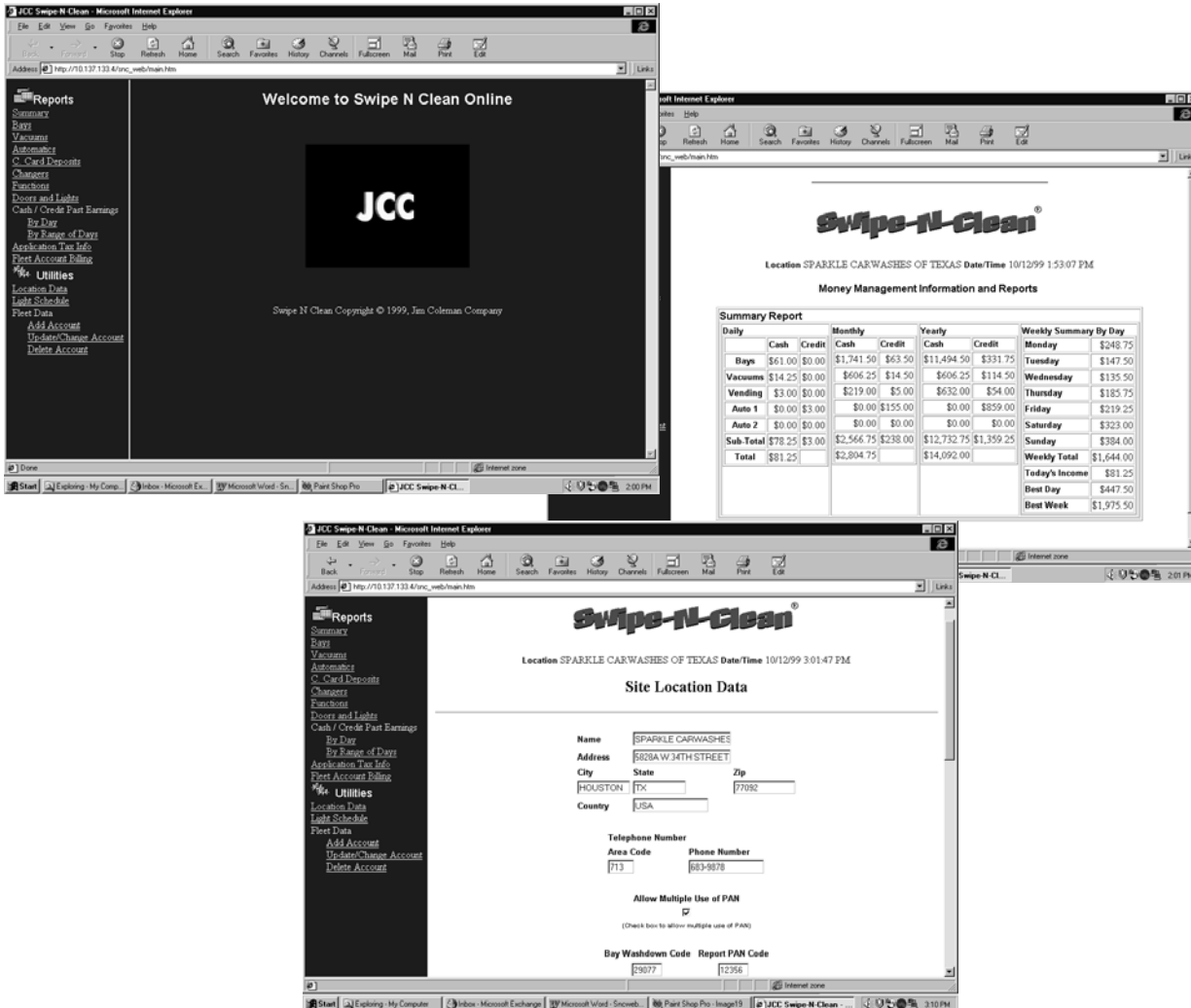

YOUR PC MUST MEET THE FOLLOWING REQUIREMENTS:

1. PC running Windows 95 or higher.
2. Have a modem installed (14.4 BPS or higher recommended for best performance.)
3. Have one of the following Browsers installed.
 - a. Netscape Navigator, version 4x or above.
 - b. Microsoft Internet Explorer, version 4x or above.
4. Have TCP/IP communications software installed (included with Windows 95 or higher).

BEFORE YOU BEGIN, MAKE SURE YOU HAVE YOUR WINDOWS 95 OR 98 INSTALLATION CD OR FLOPPY DISK, YOU MAY BE ASKED TO USE IT.

1. Install Modem.
After successful installation and testing of new modem – Proceed as follows.
2. Install Dial-Up Adapter
Double click “My Computer”. If “Dial-Up Networking” appears, close “My Computer” by clicking the X at the top right corner of the screen, skip on to Step # 7. If “Dial-Up Networking” does not appear go to Step #3.
3. Double click “Control Panel” from inside “My Computer”.
4. Double click “Add/Remove Programs” from inside “Control Panel”.
5. Click “Windows Setup” tab at top of screen, click on “Communications” until the box has a check mark and is not shaded. It should also have 2.0 MB to the right. Now click “OK”.
*Files will be copied from Windows 95+ installation disk. (You may be prompted to insert Win95+ CD or floppy disk).
Click “OK” to the message “You must provide...”select the “Network Identification” tab at the top of the page. Type My Computer in the field for “Computer Name”. Type Workgroup in the field for “Workgroup”, click “Close”.

***More files will be copied from the Windows 95+ Installation disk. , (Again you may be prompted to insert Win 95+ CD or floppy disk, if using a floppy disk this step may take up to 30 minutes). Click “OK” to “restart”. Reboot may not occur at this point but a reboot later will be required.*
6. Close “Control Panel” by clicking the X at the top right corner of the screen. Close “My Computer” by clicking the X at the top right corner of the screen. Double click “My Computer” icon from desktop. If “Dial-Up Networking” does not appear go back to Step #3 and repeat Step #3 through #5.
7. From within “My Computer” double click “Dial-Up Networking”. If there has been no prior connection, click “Next” or if there has already been a network connection of some type, and you are skipping from Step #2, double click “Make New Connection”. Type “Your Location Name” in the field for “Computer You Are Dialing”, click “Next”. Type “The Area Code of The Location You Are

GETTING CONNECTED

Calling” in the box for “Area Code”, Type “Your Location Phone Number” in the box for “Phone Number”, click “Next”, then click “Finish”. “Your Location Name” icon should appear in “Dial-Up Networking”.

8. Right click on “Your Location Name” icon, click “Properties”, click “Server Types”. Verify that “Type of Dial-Up Adapter” is set “PPP” and that only “Require Encrypted Password” and “TCP/IP Settings” are checked.
9. Click “TCP/IP Settings”; verify that “Specify an IP address” is picked. Type this number in the “IP Address:” box 10.137.133.100. Verify that Specify name server addresses is picked. Type your site location IP address in both the Primary Wins: and Secondary Wins: boxes. Your site IP address is assigned by Jim Coleman Company and will not ever change. Your site IP Address is: 10.137.133.? . Replace? with _____ for this location. (See attached site sheet for additional information) Verify that “Use IP header compression” and “Use default gateway on remote network” are both checked. Click “OK” and “OK” again. Close any open Windows by clicking the X at the top right corner of the screen.
10. Install TCP/IP Protocol
Click “Start”; click “Settings”, click “Control Panel”, double click “Network”. If “TCP/IP” Dial-Up adapter appears under “Network”, click “OK”. Close any open Windows by clicking the X at the top right corner of the screen, and then skip to Step #12. If “TCP/IP” Dial_Up adapter does not appear, click “Add”, Click “Protocol”, click “Add”, click “Microsoft” and “TCP/IP”. Click “OK”, click “OK”, and then click “OK” again. ****Files will be copied from Windows 95+ Installation disk. (You may be prompted to insert Windows 95+ CD or Floppy disk). Click “Yes” to restart. A complete restart is required now, remove any CD or floppy.*
11. Initial Logon
If “No Future Messages” box appears, click “Yes”.
12. Double click “My Computer”, double click “Dial-Up Networking”, double click your “Your Location Name” (Set-up in Step #7) icon in “Dial-Up Networking”. Your User Name is _____ and Password is _____.
Verify that the phone number corresponds to the number used in Step #7. If changes need to be made go to “Dial Properties”
13. Click “Connect” to place call to “Your Car Wash Location”.
14. After connection has been established, open your browser (Microsoft Internet Explorer (ver.4.00 or higher) or Netscape Navigator, (ver 3.00 or higher). Set “Address Path” to **10.137.133.?/snc web/main.htm** (Replace ? with site number given in Step #9.)
15. Recommended display setting should be 800 x 600. Click “Control Panel”, double click “Display” then click on the tab for “Settings.” Change “Color Palette” to 256 or higher and “Desktop Area to 800 x 600 or higher.

SITE INFORMATION REQUEST FORM

Customer Name: _____

Site Location: _____

Site Name: _____

Site AP Address: _____

Site Phone #: _____

Login ID: _____

Login Password: _____

Address Path: _____

SWIPE-N-CLEAN INCOME MONITORING MENUS

The welcome screen will be the first screen viewed by the user. This screen will offer the user their elected path to receiving data. Once a menu function has been chosen the welcome screen will go away and not be seen again until the user logs in the next time.

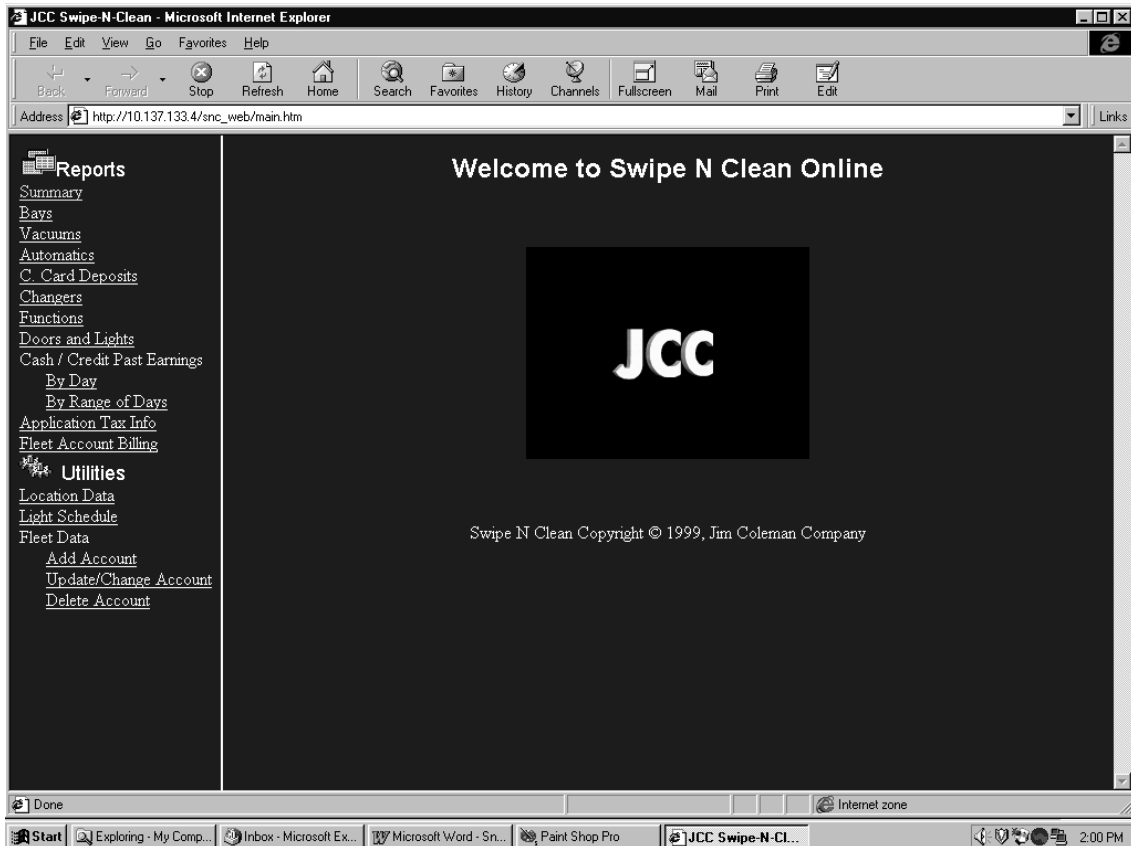

SWIPE-N-CLEAN INCOME MONITORING MENUS

These two sections control or manage all functions of the system. These sections are Reports and Utilities.



The Reports area is just that. Any data that is recoverable is displayed on the screens as that report is selected. This report is then viewable as is or can be printed, using the default printer on your windows system.



The Utilities area is used to set-up the system, control functions, manage fleet information. This data can also be viewed on the screen or printed if need be.

REPORTS

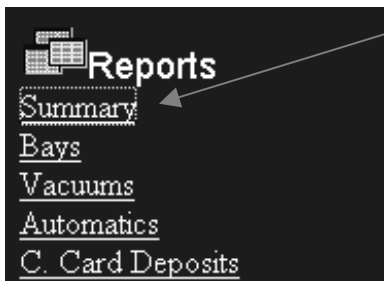

Summary - This report is the basis of all reports and by far will be used the most. It includes pertinent data to the sight such as the Location Name and Date/Time, income by Bay, Vacuum, Vending, Auto1 & 2. It also shows cash and credit. It will reflect Current, Monthly, and Year to Date data. Weekly summary by day is included on this report as well as Today's Income, Best Day and Best Week. Each of these will be discussed in detail and how to use this data.

Swipe-N-Clean®

Location SPARKLE CARWASHES OF TEXAS Date/Time 10/12/99 1:53:07 PM

Money Management Information and Reports

Daily	
Cash	
Bays	\$61.00
Vacuums	\$14.00
Vending	\$0.00
Auto 1	\$0.00
Auto 2	\$0.00
Sub-Total	\$2,566.75
Total	\$2,804.75

Monthly		Yearly	
Cash	Credit	Cash	Credit
\$1,741.50	\$63.50	\$11,494.50	\$331.75
\$606.25	\$14.50	\$606.25	\$114.50
\$219.00	\$5.00	\$632.00	\$54.00
\$0.00	\$155.00	\$0.00	\$859.00
\$0.00	\$0.00	\$0.00	\$0.00
\$2,566.75	\$238.00	\$12,732.75	\$1,359.25
\$2,804.75		\$14,092.00	

Monday	\$248.75
Tuesday	\$147.50
Wednesday	\$135.50
Thursday	\$185.75
Friday	\$219.25
Saturday	\$323.00
Sunday	\$384.00
Weekly Total	\$1,644.00
Today's Income	\$81.25
Best Day	\$447.50
Best Week	\$1,975.50

The Location Data is displayed on every report in the event that a customer has multiple sites. Date/Time is a reflection of the current time that this report is being viewed for future record purposes.

The Summary report reflect data stored in 3 different time periods, cash and credit, by bays, vacuums, vending (with electronic vendor only), and autos 1&2 (If installed), subtotals of cash and credit, and total income.

Daily is a 24-hour period of time. The default time would begin at 12:00 AM end at 11:59 PM. However in location the user has the option setting their ending time for reconciliation purposes as they wish, which will be covered later under location data. All daily data is reset* at the default time or the user set time whichever is applicable. Any time that this report is viewed or printed the amount shown reflect the data gathered from the last reset time.

Summary Report

Daily			Monthly		Yearly	
	Cash	Credit	Cash	Credit	Cash	Credit
Bays	\$61.00	\$0.00	\$1,741.50	\$63.50	\$11,494.50	\$331.75
Vacuums	\$14.25	\$0.00	\$606.25	\$14.50	\$606.25	\$114.50
Vending	\$3.00	\$0.00	\$219.00	\$5.00	\$632.00	\$54.00
Auto 1	\$0.00	\$3.00	\$0.00	\$155.00	\$0.00	\$859.00
Auto 2	\$0.00	\$0.00	\$0.00	\$0.00	\$0.00	\$0.00
Sub-Total	\$78.25	\$3.00	\$2,566.75	\$238.00	\$12,732.75	\$1,359.25
Total	\$81.25		\$2,804.75		\$14,092.00	

and
data
of

Monthly is a 28,29,30, or 31-day period depending on which month it applies. At the end of the monthly period data is reset*.

Yearly is from January 1 – December 31. At the end of the yearly period data is reset*.

**Reset Data – Data is never cleared or lost. It will continue to allow the user data access across any time period.*

Income Name	Description
Bays	Total of all bays.
Vacuums	Total of all vacuums.
Vending	Income from all Jim Coleman Company provided electronic vendors only.
Auto 1	Total cycle income. Displays credit only cash interface being developed.
Auto 2	Total cycle income. Displays credit only cash interface being developed.
Subtotal	Cash and Credit totals
Total	Sum of Cash and Credit.

REPORTS-WEEKLY SUMMARY BY DAY

Monday	\$248.75
Tuesday	\$147.50
Wednesday	\$135.50
Thursday	\$185.75
Friday	\$219.25
Saturday	\$323.00
Sunday	\$384.00
Weekly Total	\$1,644.00
Today's Income	\$81.25
Best Day	\$447.50
Best Week	\$1,975.50

Weekly Summary by Day is the recorded and summed data for the past 7 days. This is referred to as a rolling 7-day sum. At the end of each day, the day total income for that day (cash and credit) is written into the cell of that day. Example: Today is Monday. When the user looks into the cell for Monday it has \$248.75 in it. This amount reflects the amount of income from last Monday. At the end of today the amount of income that was recorded will be put into the cell for Monday. Also at this time the total will change showing the new amount for the previous 7 days.

Today's Income is the amount of income recorded since the last reset time.

Best Day and Best Week is non-resettable data that will reflect a change as it occurs. Any time 1-day or daily data exceeds the recorded amount in the Best Day cell the new amount will be written into the Best Day cell. Correspondingly when any seven days of income is greater than the amount recorded in the Best Week cell that amount will be written into the Best Week cell. This area of data is a benchmark of how the site is or has been performing.

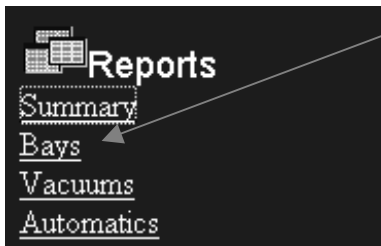

Bays - This report is the breakdown of each bay by number reflecting the data in a daily, monthly, and yearly format. The sum total of the bays is the amount reflected on the summary report for the bays cell. This data can be used to evaluate bay usage by bay. It also provides and proves communications from the timers and push button controllers, which are the gathering tools of the system.

Location SPARKLE CARWASHES OF TEXAS Date/Time 10/12/99 1:54:20 PM

Money Management Information and Reports

Bay Report

Daily	Monthly		Yearly			
	Cash	Credit	Cash	Credit		
Bay1	\$35.50	\$0.00	\$817.75	\$42.00	\$5,565.00	\$140.50
Bay2	\$25.50	\$0.00	\$923.75	\$21.50	\$5,929.50	\$191.25
Bay3	\$0.00	\$0.00	\$0.00	\$0.00	\$0.00	\$0.00
Bay4	\$0.00	\$0.00	\$0.00	\$0.00	\$0.00	\$0.00
Bay5	\$0.00	\$0.00	\$0.00	\$0.00	\$0.00	\$0.00
Bay6	\$0.00	\$0.00	\$0.00	\$0.00	\$0.00	\$0.00
Bay7	\$0.00	\$0.00	\$0.00	\$0.00	\$0.00	\$0.00
Bay8	\$0.00	\$0.00	\$0.00	\$0.00	\$0.00	\$0.00
Bay9	\$0.00	\$0.00	\$0.00	\$0.00	\$0.00	\$0.00
Bay10	\$0.00	\$0.00	\$0.00	\$0.00	\$0.00	\$0.00
Total	\$61.00	\$0.00	\$1,741.50	\$63.50	\$11,494.50	\$331.75

VACUUM INCOME REPORT

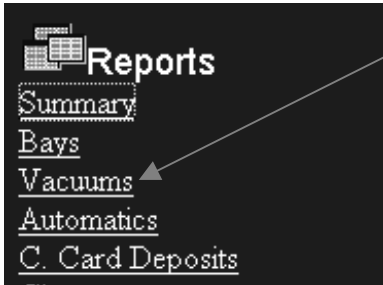

Vacuums - This report is the breakdown of each vacuum by number reflecting the data in a daily, monthly, and yearly format. The sum total of the vacuums is the amount reflected on the summary report for the vacuum cell. This data can be used to evaluate vacuum usage by vacuum. It also provides and proves communications from the timers and push button controllers, which are the gathering tools of the system.

Swipe-N-Clean®

Location SPARKLE CARWASHES OF TEXAS Date/Time 10/12/99 1:55:04 PM

Money Management Information and Reports

Vacuum Report

	Daily		Monthly		Yearly	
	Cash	Credit	Cash	Credit	Cash	Credit
Vac1	\$2.75	\$0.00	\$156.50	\$2.25	\$954.25	\$36.75
Vac2	\$4.75	\$0.00	\$237.75	\$7.00	\$237.75	\$43.25
Vac3	\$6.75	\$0.00	\$212.00	\$5.25	\$1,295.00	\$34.50
Vac4	\$0.00	\$0.00	\$0.00	\$0.00	\$0.00	\$0.00
Vac5	\$0.00	\$0.00	\$0.00	\$0.00	\$0.00	\$0.00
Vac6	\$0.00	\$0.00	\$0.00	\$0.00	\$0.00	\$0.00
Vac7	\$0.00	\$0.00	\$0.00	\$0.00	\$0.00	\$0.00
Vac8	\$0.00	\$0.00	\$0.00	\$0.00	\$0.00	\$0.00
Vac9	\$0.00	\$0.00	\$0.00	\$0.00	\$0.00	\$0.00
Vac10	\$0.00	\$0.00	\$0.00	\$0.00	\$0.00	\$0.00
Vac11	\$0.00	\$0.00	\$0.00	\$0.00	\$0.00	\$0.00
Vac12	\$0.00	\$0.00	\$0.00	\$0.00	\$0.00	\$0.00

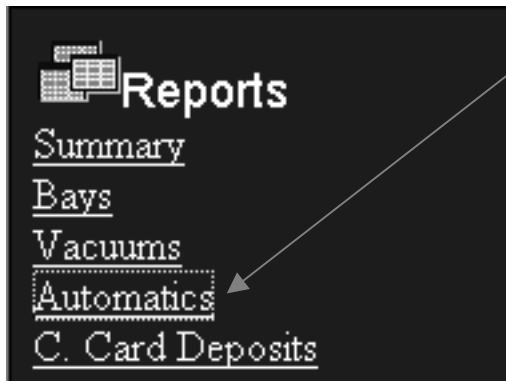

Automatic - This report is the breakdown of each automatic bay by cycle. It reflects the data in a daily, monthly, and yearly format. The sum total of the automatic is the amount reflected on the summary report for the automatic cell. This data can be used to evaluate cycle usage preferred by your customers. It also provides and proves communications from the auto cashier, which are the gathering tools of the system.

Swipe-N-Clean®

Location SPARKLE CARWASH Date/Time 5/26/00 10:56:09 AM

Money Management Information and Reports

Automatics Report

Daily		Monthly	Yearly
Automatic1	Automatic 1	Automatic 1	Automatic 1
Cycle 1	\$8,958.00	\$0.00	\$0.00
Cycle 2	\$2,585.00	\$0.00	\$0.00
Cycle 3	\$872.00	\$0.00	\$0.00
Cycle 4	\$1,092.00	\$0.00	\$0.00
Total	\$0.00	\$0.00	\$0.00
Automatic2		Automatic 2	Automatic 2
Cycle 1	\$0.00	\$0.00	\$0.00

CREDIT CARD DEPOSIT REPORT

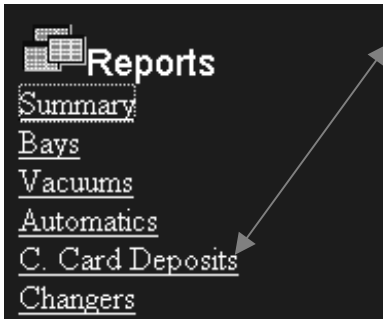

Credit Card Deposits – This report is used to reconcile your daily Credit Card Deposits with your processor and bank. The daily deposit will be over written each month by the following month’s day. For example on 10/01/199 the report shows \$5.25 for the day’s deposit. That amount will remain in that cell until 11/01/1999 at which time that day’s amount will be written in. This report also reflects Today’s, Best Day, Best Week, and Total Users. This is non-resettable data used to benchmark progress. The last item reflected in the average dollar amount by user.

Swipe-N-Clean®

Location SPARKLE CARWASHES OF TEXAS Date/Time 10/12/99 1:56:46 PM

Money Management Information and Reports

Credit Card Deposits and Data			
Deposits		Data	
Date	Amount	Date	Amount
10/01/1999	\$5.25	09/17/1999	\$48.25
10/02/1999	\$9.00	09/18/1999	\$24.25
10/03/1999	\$6.50	09/19/1999	\$32.00
10/04/1999	\$2.50	09/20/1999	\$22.00
10/05/1999	\$24.50	09/21/1999	\$6.00
10/06/1999	\$15.50	09/22/1999	\$16.00
10/07/1999	\$28.00	09/23/1999	\$23.00
10/08/1999	\$24.00	09/24/1999	\$21.00
10/09/1999	\$33.25	09/25/1999	\$36.75
10/10/1999	\$45.00	09/26/1999	\$32.75
10/11/1999	\$41.50	09/27/1999	\$18.50
09/12/1999	\$21.00	09/28/1999	\$0.00
09/13/1999	\$9.50	09/29/1999	\$8.75
09/14/1999	\$1.00	09/30/1999	\$11.00

Today's Users	1
Best Day	5
Best Week	1
Total	694
Average	\$5.24

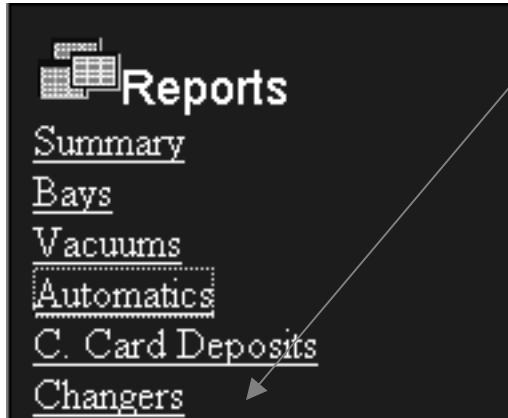

Changers - This report is a status report of each changer on site. It reflects the date and time the changer was down; the date and time the changer was back up; and the current status of each changer.

Swipe-N-Clean®

Location SPARKLE CARWASH Date/Time 5/26/00 10:57:14 AM

Money Management Information and Reports

Changer 1		
Changer Down	Changer Up	Status
4/25/00 2:38:26 PM	4/25/00 2:38:27 PM	UP

Changer 2		
Changer Down	Changer Up	Status
N/A	N/A	N/A

Changer 3		
Changer Down	Changer Up	Status
N/A	N/A	N/A

Changer 4		
Changer Down	Changer Up	Status

FUNCTIONS USAGE REPORT

Functions Report – The functions report is used to reflect usages on each bay function of the car wash. It also reflects the amount of time and income produced by each function.

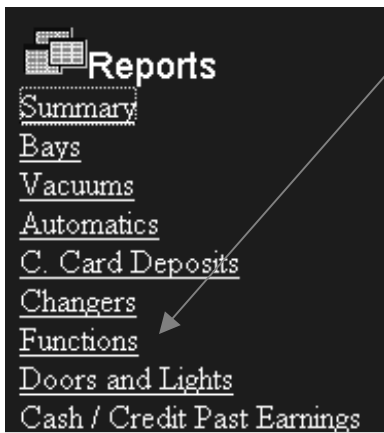

Function Report

Function	Total Time In Use	%
Stop	866	0.5
Tire Cleaner	7348	3.9
Presoak	4341	2.3
Soap	29009	15.6
Foam Brush	39501	21.2
Rinse	62245	33.4
Foaming Conditioner	7647	4.1
Clear Coat Protectant	5195	2.8
Wax	14043	7.5
Spot Free Rinse	16221	8.7

REPORTS-DOOR AND LIGHTS ACTIVITY REPORT



Door and Lights Activity Report - This report reflects door open and close activity per day and the current status of the door. This report also reflects the on/off setting for the lights and the current status of the lights.

Swipe-N-Clean[®]

Location SPARKLE CARWASH Date/Time 5/26/00 10:57:33 AM

Money Management Information and Reports

Door and Light Activity Report

Door						Lights		
Date	Time	Status	Date	Time	Status	On Time	Off Time	Statu
Door1Date	Door1Time	CLOSED	Door11Date	Door11Time	0	17:00:00 PM	07:00:00 AM	OFF
Door2Date	Door2Time	0	Door12Date	Door12Time	0			
Door3Date	Door3Time	0	Door13Date	Door13Time	0			
Door4Date	Door4Time	0	Door14Date	Door14Time	0			
Door5Date	Door5Time	0	Door15Date	Door15Time	0			
Door6Date	Door6Time	0	Door16Date	Door16Time	0			

REPORTS-CASH / CREDIT PAST EARNINGS REPORT

Cash / Credit Past Earnings – The past earnings reports are used to look up previous days or a range of days. All data is stored and can be retrieved using these reports.

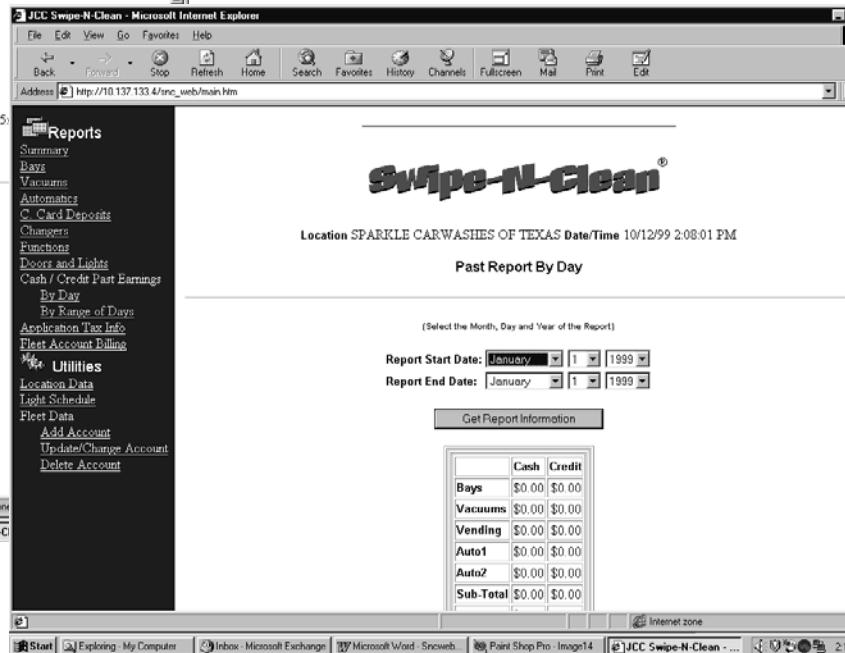
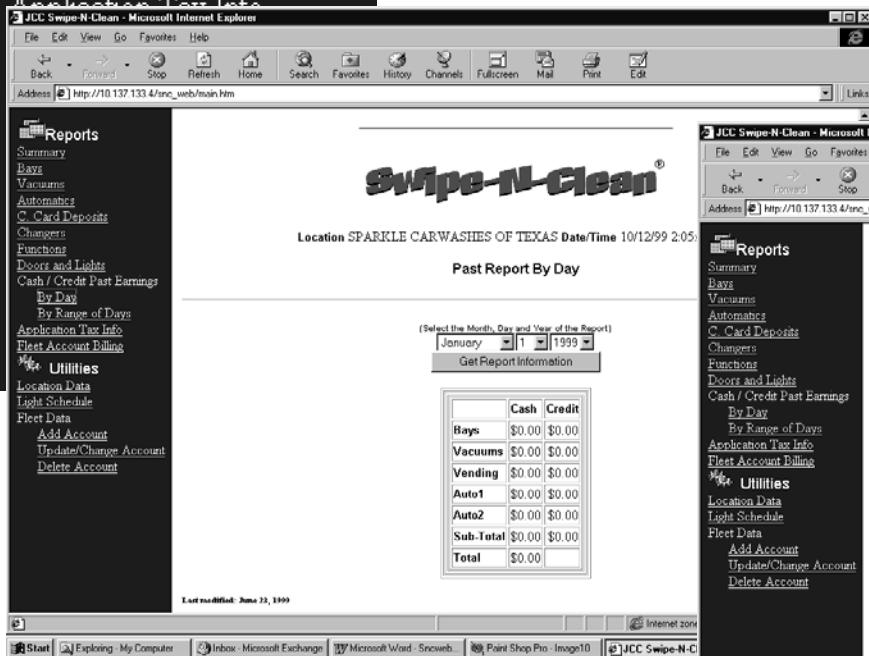

REPORTS-APPLICATION TAX INFORMATION REPORT

Application Tax Info – The application tax only applies if you are subject to taxes on products. Some states require an audit trail for taxation purposes and this report provides that data. The application tax info is setup in the Location Data area and is done at setup. The data is broken down by bay and by month and then summarized.

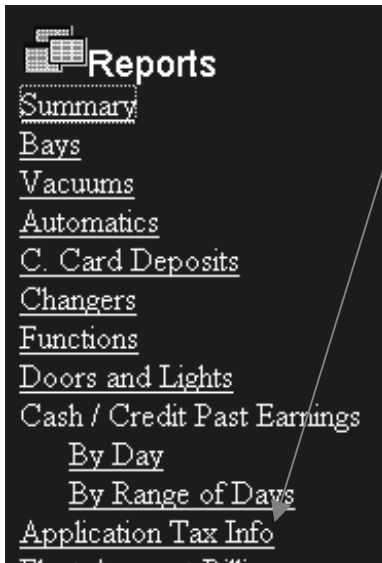

Location SPARKLE CARWASHES OF TEXAS Date/Time 10/12/99 2:16:23 PM

Application Tax Report

(Select The Year To Search)

1999
Submit

Month	Bay 1	Bay 2	Bay 3	Bay 4	Bay 5	Bay 6	Bay 7	Bay 8	Bay 9	Bay 10	Total Monthly Tax
January	\$0.00	\$0.00	\$0.00	\$0.00	\$0.00	\$0.00	\$0.00	\$0.00	\$0.00	\$0.00	\$0.00
February	\$0.00	\$0.00	\$0.00	\$0.00	\$0.00	\$0.00	\$0.00	\$0.00	\$0.00	\$0.00	\$0.00
March	\$0.00	\$0.00	\$0.00	\$0.00	\$0.00	\$0.00	\$0.00	\$0.00	\$0.00	\$0.00	\$0.00
April	\$0.00	\$0.00	\$0.00	\$0.00	\$0.00	\$0.00	\$0.00	\$0.00	\$0.00	\$0.00	\$0.00
May	\$0.00	\$0.00	\$0.00	\$0.00	\$0.00	\$0.00	\$0.00	\$0.00	\$0.00	\$0.00	\$0.00
June	\$0.00	\$0.00	\$0.00	\$0.00	\$0.00	\$0.00	\$0.00	\$0.00	\$0.00	\$0.00	\$0.00
July	\$0.00	\$0.00	\$0.00	\$0.00	\$0.00	\$0.00	\$0.00	\$0.00	\$0.00	\$0.00	\$0.00
August	\$0.00	\$0.00	\$0.00	\$0.00	\$0.00	\$0.00	\$0.00	\$0.00	\$0.00	\$0.00	\$0.00
September	\$0.00	\$0.00	\$0.00	\$0.00	\$0.00	\$0.00	\$0.00	\$0.00	\$0.00	\$0.00	\$0.00
October	\$0.00	\$0.00	\$0.00	\$0.00	\$0.00	\$0.00	\$0.00	\$0.00	\$0.00	\$0.00	\$0.00
November	\$0.00	\$0.00	\$0.00	\$0.00	\$0.00	\$0.00	\$0.00	\$0.00	\$0.00	\$0.00	\$0.00

REPORTS-FLEET ACCOUNT BILLING REPORT

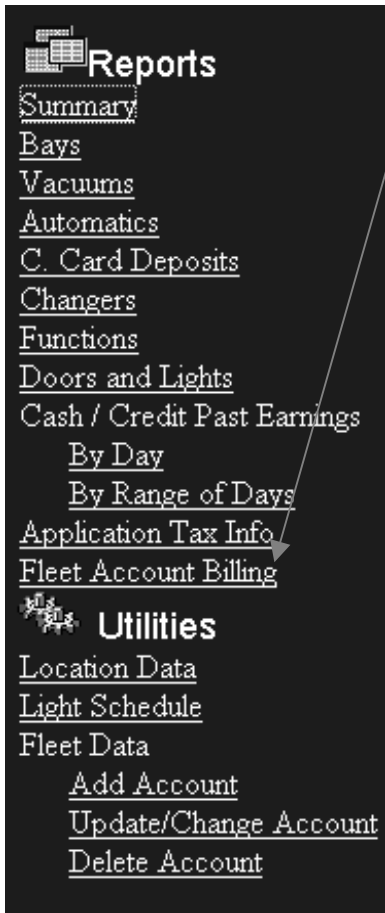

Fleet Accounting Billing – This report is used to retrieve fleet account billing data. It is used in conjunction with the fleet account setup under utilities. An account is selected from the list in the drop down box. The data displayed will reflect the complete account amount broken down by user codes. Setup of fleet accounts will be discussed under utilities.

SYSTEM UTILITIES – LOCATION DATA

Utilities
[Location Data](#)
[Light Schedule](#)
[Fleet Data](#)
[Add Account](#)
[Update/Change Account](#)
[Delete Account](#)

Location Data – The location data section of utilities store all of the site data necessary to operate the site, reconcile the reports, and properly record the data. Each section will be covered describing the data required.

Name
Address
City **State** **Zip**
Country

Site Name and Address information will be used to header each report and print on receipts

Telephone Number

Area Code **Phone Number**

Maximum Customer Credit

Limit In Dollars

Number of:

Wash Bays:
Vac Only:
Frag Only:
Sham Only:
Vac/Frag:
Vac/Sham:
Automatics:
Changers:
Doors:

This lists all devices and the quantity of each.

Cost Information

Device Type	Start Price	Stop Price
Wash Bay	<input type="text" value="5"/>	<input type="text" value="20"/>
Vacuum	<input type="text" value="3"/>	<input type="text" value="3"/>
Fragrance	<input type="text" value="3"/>	<input type="text" value="3"/>
Shampoo	<input type="text" value="10"/>	<input type="text" value="10"/>
Automatic Cycle 1	<input type="text" value="24"/>	<input type="text" value="24"/>
Automatic Cycle 2	<input type="text" value="20"/>	<input type="text" value="20"/>
Automatic Cycle 3	<input type="text" value="16"/>	<input type="text" value="16"/>
Automatic Cycle 4	<input type="text" value="12"/>	<input type="text" value="12"/>

Start price is the amount of coins used to turn the device on. Stop price is the max amount that the device will run until it turns off. Example: Wash bays will start at \$1.25 and turn off at \$5.00. Vacuums will start at \$.75 and turn off when \$.75 amount of time is

SYSTEM UTILITIES-LIGHT SCHEDULE

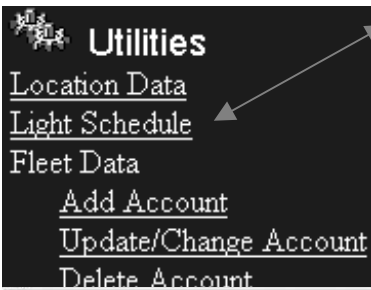

Light Schedule – The light schedule section of utilities allows the user to customize when the lights turn on and off throughout the site on a monthly basis.

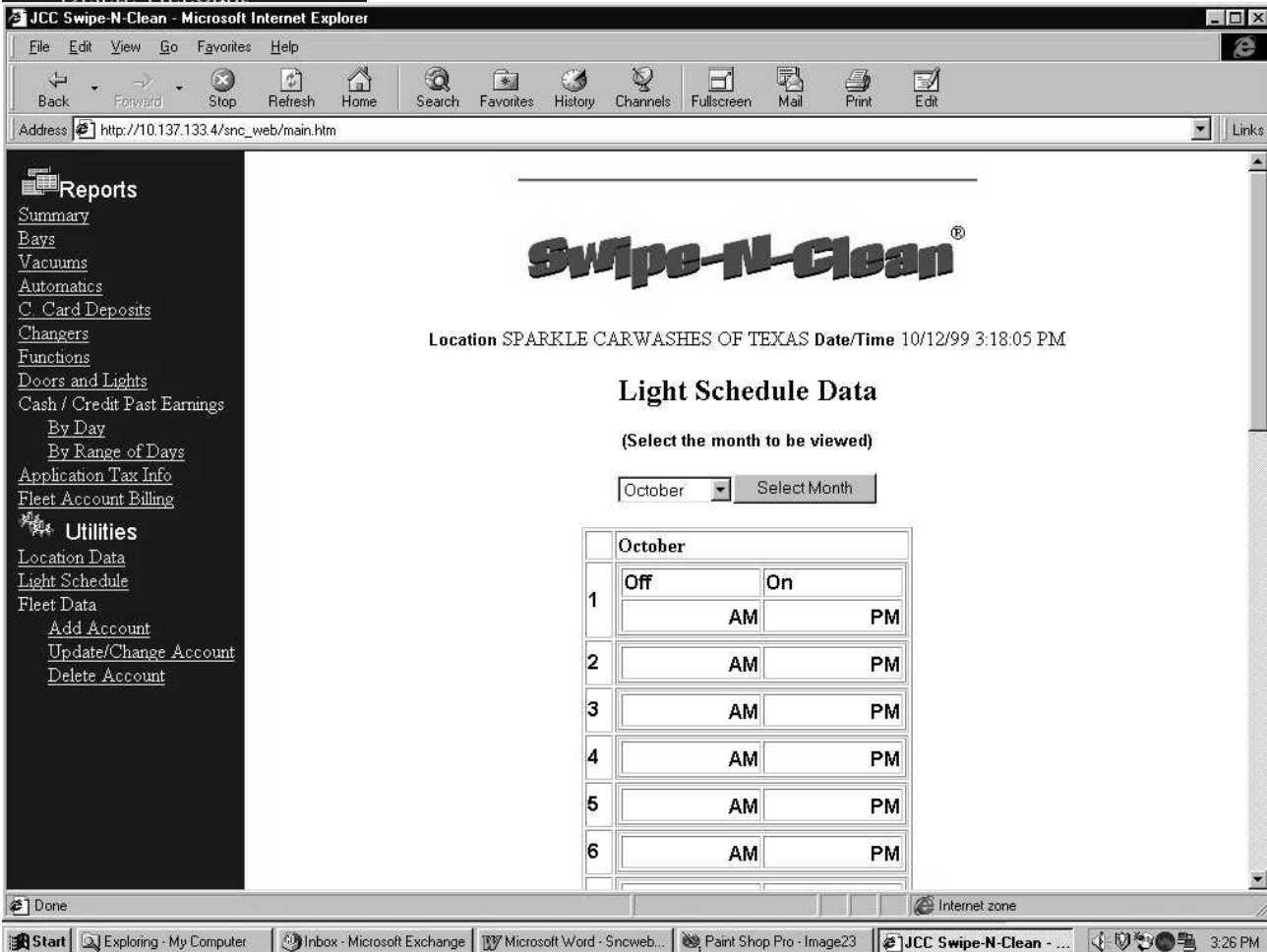

SYSTEM UTILITIES-FLEET DATA – ADD FLEET ACCOUNT USER

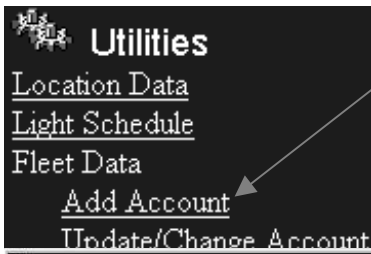

Add Account – Selecting the option “Add Account” from the Utilities section will allow you to add users to your fleet service accounts.

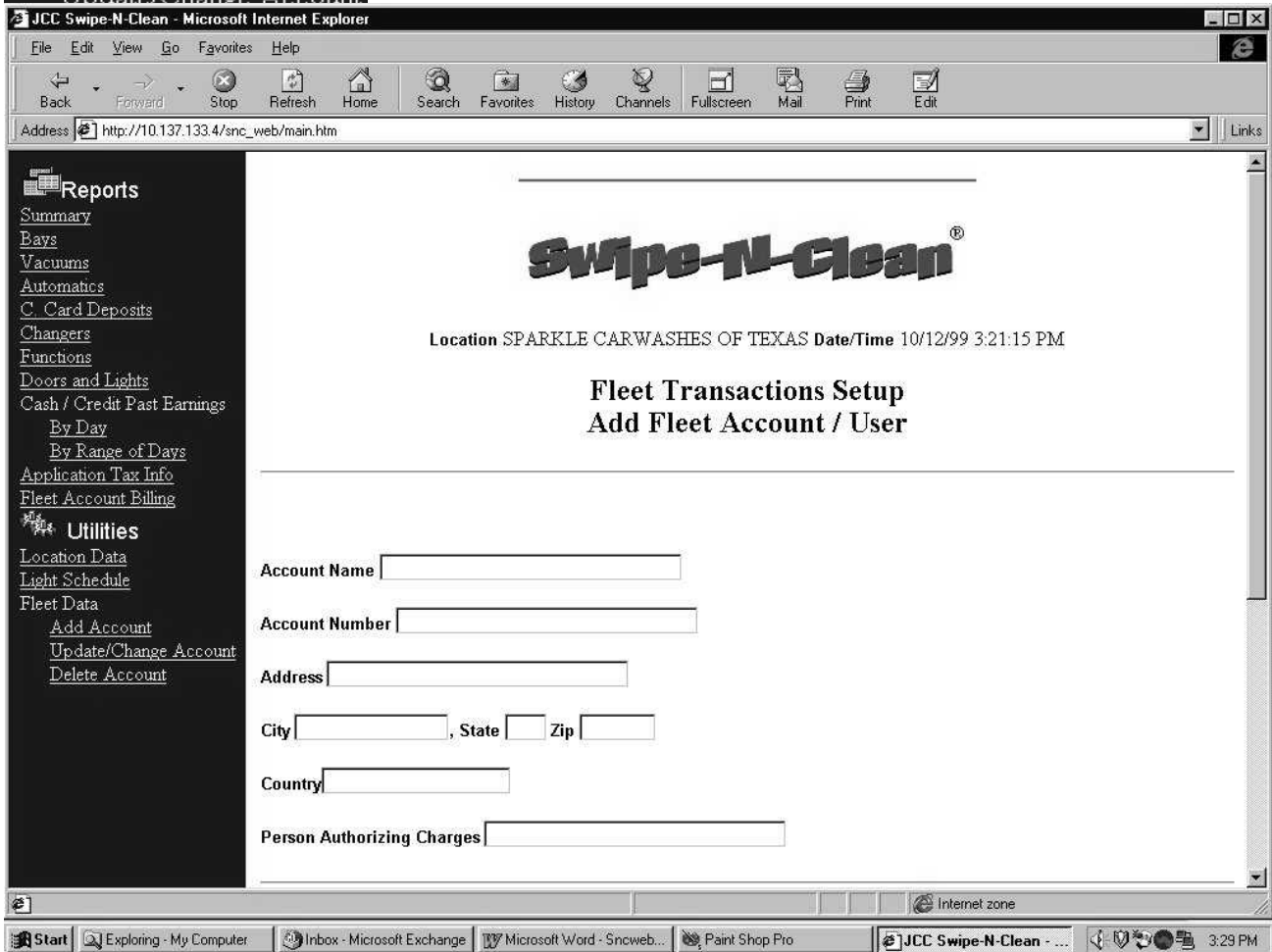

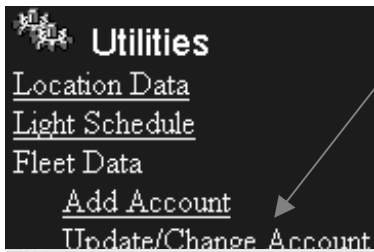

Update / Change Account selection is provided for the purpose of changing or updating information on existing fleet account users.

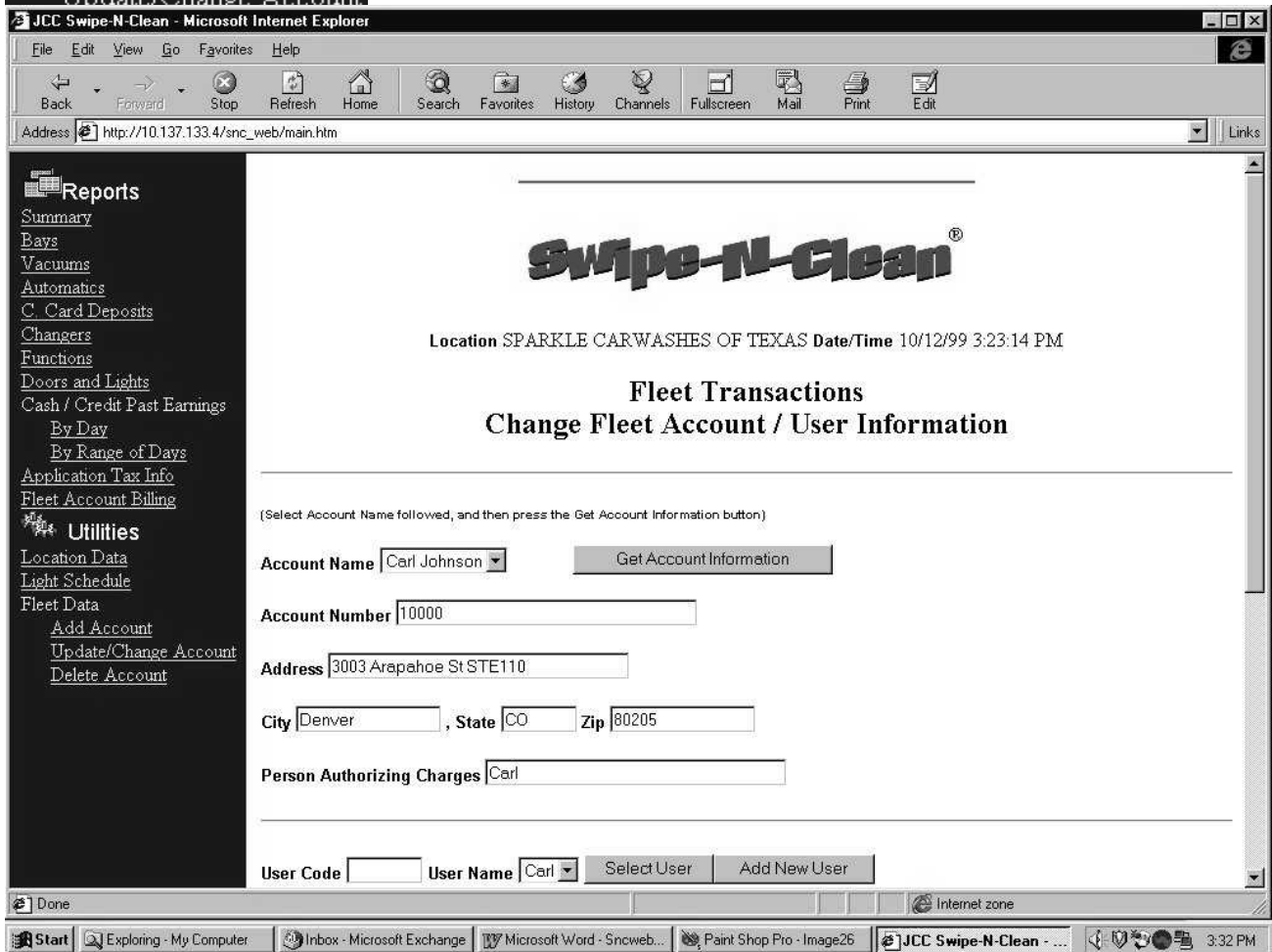

SYSTEM UTILITIES-FLEET DATA – UPDATE / CHANGE ACCOUNT

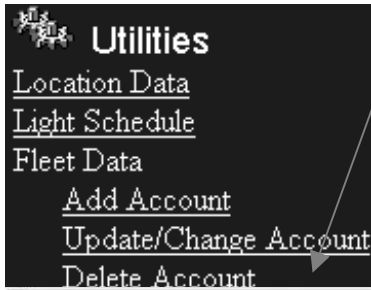

Delete Account selection is provided for the purpose of deleting a user from the fleet account.

Utilities
[Location Data](#)
[Light Schedule](#)
[Fleet Data](#)
[Add Account](#)
[Update/Change Account](#)
[Delete Account](#)

Reports
[Summary](#)
[Bays](#)
[Vacuums](#)
[Automatics](#)
[C. Card Deposits](#)
[Changers](#)
[Functions](#)
[Doors and Lights](#)
[Cash / Credit Past Earnings](#)
[By Day](#)
[By Range of Days](#)
[Application Tax Info](#)
[Fleet Account Billing](#)

Swipe-N-Clean®
 Location SPARKLE CARWASHES OF TEXAS Date/Time 10/12/99 3:24:26 PM

Fleet Transactions
Delete Fleet Account / User Information

(Select Account Name and then press the Get Account Information button)

Account Name

Account Number

Address

City , State Zip

Person Authorizing Charges

(Select User Name and then press the Select User button)

Done Internet zone

Start Exploring - My Computer Inbox - Microsoft Exchange Microsoft Word - Sncweb... Paint Shop Pro - Image27 JCC Swipe-N-Clean - ... 3:32 PM

PERIODIC MAINTENANCE

As with any system the SNC system and software needs to have certain periodic maintenance performed. The following table highlights those items on a Daily, Weekly, Monthly, and Yearly basis:



	Description	Daily	Weekly	Monthly	Yearly
1	Check operation of SNC system	2X			
2	Randomly Check Bay Operation	2X			
3	Randomly Check Vacuum Operation	2X			
4	Check daily income of SNC	X			
5	Down Computer System and reboot			X	
6	Backup Data to Disk		X		
7	Check weekly income of SNC		X		
8	Check monthly income of SNC			X	
9	Check yearly income of SNC				X
10	Reconcile Bank Statement Income with SNC income			X	
11	Verify correct operation of all bays		BI		
12	Verify correct operation of all vacuums			X	
13	Clean magnetic card reader		X		
14	Install receipt printer paper				
16	Clean cabinet face, doors, and screen		X		
17	Print System Reports	X	X	X	X
18.	Upgrade Software				X
19.	Vacuum out inside of cabinet				X
20.	Verify phone operations	X			



Symptoms	Causes and Solutions
----------	----------------------

System will not read credit card

- Magnetic card reader may be dirty. Clean card reader using Magnetic card reader cleaner card.
- Power to card reader may not be connected. Connect power back up to card reader.
- Magnetic card reader may be defective. Contact factory for help in troubleshooting and replacement.

Audio portion of SNC is not working.

- Volume control has been turned down too low. Turn volume back to an acceptable level.
- Audio speaker is disconnected. Reconnect audio speaker.
- Sound card connection has been removed. Reconnect sound card connector.
- Sound card is defective. Contact factory for replacement.

Video portion of SNC is not working.

- Video is disconnected either at the monitor or the CPU. Reconnect the video at the appropriate connection.
- Video monitor is defective. Contact factory for replacement.

Printer is printing lightly.

- Paper is wet. Replace paper.

Customers are not getting receipts.

- Printer is jammed. Unjam paper and reload.
- Customer is not returning to the SNC and putting in code. Instruct customer on proper usage of the SNC.

Customer billing is too high.

- Customer left bay of vacuum running without pressing stop. Instruct customer on proper usage of the SNC and issue a credit through IC Verify.



Symptoms

Causes and Solutions

System is not working at all.

- Contact factory for troubleshooting help.

Unit is not responding to functional test codes or use codes (i.e. no: (bill \$.00)

- Timer and/or PBC Board not in communication with SNC Computer. Cycle power to unit – wait for time display to engage within 3 seconds of re-energizing.

System not responding as above

- Temporary power outs/brown out may shut entire system down for a longer period of time than backup can keep the computer up and running. All units need a re-energizing as above to establish communication with the SNC Computer.

TECHNICAL TRAINING

Installation:

MATERIALS

- SWIPE N CLEAN CABINET ASSEMBLY
- JCCTXSRV COMPUTER
- 1030 PBC BAY CONTROL BOARD(S).....Manual/page II-2
- 1036 PBC VAC CONTROL BOARD(S).....Manual/page II-4
- 1037 PBC VEND CONTROL BOARD(S).....Manual/page II-7
- 1034S TIMER).....Manual/page II-9
- 33.6 MHZ FAX MODEMS
- NULL MODEM
- 2 CDR AWG 22 SHIELDED/GROUND

PROCEDURE

Each unit should arrive with the appropriate PBC board and timer already installed from the JCC factory.

It will be necessary for the receiver of the units to ensure each unit is SNC capable upon delivery. Pre-delivery construction of the site must include installation of sufficient conduit to connect the communication network of the JCCTXSRV computer to each unit of the site.

- (1. *Generally the cabling for the bays are routed along with the control cabling back to the Super Saver control panel; then brought to the SNC cabinet as one bundle.*
- (2. *Vacuums are typically routed individually but some locations do bring individual vacuums together at a homerun before making the final approach to the SNC cabinet.*
- (3. *Vendors need both a communication pair run to the SNC cabinet and power cable run to the Super Saver control panel.*
- (4. *Automatics need a conduit for low voltage cables brought to the SNC cabinet and a conduit for high voltage brought to the auto control panel.*

Bays, vacuums, and vendors are hard wired between the PBC and timers back to the communication ports of the JCCTXSRV computer. The automatic is hard wired from the controller of the automatic entrance control back to an isolated comm. Port of the JCCTXSRV computer.

Each device of the system is uniquely identified by its location address. This address is critical for the system to operate as designed. Improper addressing of any device will create a malfunction in the system's integrity. The proper procedure for addressing is found in chapter V of the SWIPE-N-CLEAN OPERATOR'S MANUAL. We generally identify each unit by standing at the street facing the front entrance of the carwash and starting from left to right front to back number each bay in ascending numerical order; repeating the same process with vacuums and vendors.

Operations:

- (1. Each device is designed to operate as a coin only device and can be accessed by adding coins until the required amount of money has been received.
- (2. These units will not operate in the SNC mode until the JCCTXSRV computer recognizes them.
- (3. One can ensure the bays and vacuums are SNC operational by doing a simple test at each unit after the JCCTXSRV computer is on and the credit card application is running. Using the keypad at each of these devices input the code 123456# and wait for the timer to return the response “bill \$0.00”, twice.
- (4. The correct response indicates the devices are recognized as compatible pairs of that unit and is accepting both credit card and fleet code information input from the keypad of that unit.

TROUBLESHOOTING	
PROBLEM	SOLUTION
1. No response to six-digit fleet code at any SNC equipped bay or vacuum.	Check both timer and PBC board to ensure they react to power up within three (3) seconds.
1a. If no good.	Check each device separately to determine if one or both devices are not responding correctly. <i>(Ensure both devices have their two pin communication leads connected to the con 5 connector on the 1034 & 1036 PBCs)</i>
1b. If good.	Check both devices to verify addresses are paired up.
1c. If no good.	Program both devices to pair up to the same unit.
1d. If good.	Check the six-digit code to determine “bill \$0.00” response.

Note 1: Device information table is located in the Microsoft Access SNC_Database. * You may have to call for instructions on how to find or access this table.**

PROBLEM	SOLUTION
1e. If no good.	Check <i>device information;</i> table for <i>power-up notification times.</i> a. Power-up times for both the timer and the PBC board, <i>must be within (3) three seconds of each other!</i> b. Both timer and PBC board must show up upon power-ups. c. Both timer and PBC board must show up on the same communication port.
1f. If good, then	Cycle power at main power panel for control transformer of the Super Saver. Then check the six-digit code to determine if you have a “bill \$0.00” response. **Note** Exception electronic vend PBC / timer combinations. See Note 2

Note 2: Vacuums cycle power with circuit breaker inside the meter door. Vendors can only be tested with a valid credit card or fleet code.

1g. If no good	Check other unit devices for same location address.
----------------	---

Note 3: Vendor Islands work a little differently than bays and vacuums. Six-digit test codes will not “bill \$0.00”.

2. The vendor does not respond to a fleet or a credit card code.	<i>Reminder: See note 2 above. First you will need to have either a good fleet code or an active credit card code. Setting up fleet codes are an administrative function see carwash administrator to get a functioning fleet test code.</i>
2a. Do you have a good fleet code or an active credit card code? If yes?	<i>Enter code.</i> Listen for two quick beeps and watch for all the red LEDS on the vendor meter door to light up. Go to step 2c.
2b. If you don't have a good code?	Get one then do the solution step in 2a.
2c. Did code work? If no?	Remove the power from the timer by disconnecting the large opaque 10-pin connector from the top left connection on back of the timer. Wait 3 – 5 seconds then replace the power connector. Go to 2e.
2d. If code worked.	Check any product to ensure it vends properly. Go to 2i.
2e. Did timer display start up within three seconds? Yes?	Remove the cover from the vendor PBC board and check that LEDS flash on and off immediately after removing and reapplying power. Check the connection to the 485 communication 2-pin connector; at <i>con 6</i> . Voltage at each of the pins should be ~ 2.5 vdc.
2f. Did the vendor PBC react as indicated above in 2e? Yes?	<i>Enter code.</i> Listen for two quick beeps and watch for all the red LEDS on the vendor meter door to light up. Go to step 2g.

PROBLEM	SOLUTION
2g. Did the code work? Yes?	Go to step 2d.
2h. If code did not work.	Go to step 1e.
2i. Did all products vend? No.	Are there any red flashing LEDS on products that do not vend. If yes go to 2k.
2j. Yes.	Test complete
2k. If you have red flashing LEDS	Check for out of product indicator switch. If needed refill product.
2l. Red LED is not flashing and product still does not dispense. No sounds of drive motor engaging.	Check individual vendor signal cable for good contact at plug connection. Check to determine if drive motor engages.
2m. Drive motor engages and product still does not drop.	Check dispenser rack for proper installation and adjustments.
2n. Nothing helps	Call JCC for Tech Assist.
3. Unable to get valid credit card swipe and approval.	Swipe credit card at either the JCC SNC cabinet or the automatic Hamilton ACW5 entrance control cabinet.
3a. Does voice and written messages respond to indicate card swipe has been recognized? No.	Check card reader to ensure 5vdc is available to card reader. If no 5vdc go to step 3d.
3b. Voice and written messages available to indicates card swipe has been detected.	Can you hear modem dialing and connect to bank verification network? If modem does not dial out go to step 3e.
3c. If yes, do both messages continue to indicate credit is being verified? Yes.	Does message continue until card is either approval or denied. If yes try another card and go to step 3.
3d. If no 5vdc	Check 5vdc output of the 1038 PBC at con 1. If present check the fuse on the card swipe. If the fuse and the 5vdc output are okay put dipswitch no. 1 in the on position and cycle the power to the card swipe. Return dipswitch to the off position and swipe your card again. If card swipe not detected replace card swipe.
3e. Modem does not dial out or connect to network.	Check for power indicators on the modem. If power indicator is okay. Check for working telephone line. If telephone line is good and power is turned on reset modem by cycling power to unit. Check to see if problem is resolved. If not resolved request replacement modem.
4. Printer problems	
4a. Printer paper jams.	Check printer to ensure it is snug against the front of the cabinet door. Rethread printer and test for smooth paper feed and consistency of print. Tighten print back into alignment slot.
4b. Printer does not respond to keypad access.	Is printer power turned on? Is printer connected to the correct com port? Does printer have null modem installed?
4c. Printer message is smeared, incomplete or illegible.	Clean print head. If results are unsuccessful replace print head.

Swipe-N-Clean®

	-A-				
Audio Speakers		II-1		Planning Steps	IV-1
	-B-			Printer	IV-9
Bay Connections		IV-5		• Installing Paper	IV-10
	-C-			• Maintenance	IV-9
Cabinet		II-1		• Paper Loading Steps	IV-2
Communication Cables		IV-5		Push Button Controller Board	II
Components		II		• Bay	II-2
Credit Card Processor (CCP)		III-3		• Point of Sale	II-6
	-D-			• Vacuum	II-4
Dimensions-Cabinet & Faceplate		III-1		Programming Instructions	
	-E-			• 1034 Timer	V-1
Electrical		IV-3		• Push Button Controller	V-4
• Bays		IV-5		-R-	
• Phone Line		IV-3		Receipt-Obtaining a Receipt	III-6
• SNC Cabinet		IV-3		Receipt Example	III-7
	-I-			-S-	
IC Verify		VI		Select-N-Touch	III-3
• Issuing Credit to a Customer		VI-5		• Meter Fronts	III-3
• Previewing & Settling Transactions		VI-3		• Price/Time Display	III-4
• Start-Up		VI-1		Start-Up System	VI-1
• View Settlement Transaction Report		VI-4		Swipe-N-Clean Operation	III-2
Income Monitoring		I-3		• Swiping a Credit Card	III-2
Installation		IV-2		-T-	
	-M-			Trouble-Shooting	IX-1
Maintenance		VII-1		-U-	
	-O-			Use Code	III-3
Online-Swipe-N-Clean		VII		• Assignment of Use Code	III-3
Operation		III		• Inputting at the Bay Meters	III-3
Operating Instructions-Swipe-N-Clean		III-2		• Inputting at the Vacuums	III-5
Operating Instructions-PBC Board		V-7		-V-	
Operational & Mounting Specifications		III-1		Vacuum Connections	IV-8
	-P-			-W-	
				Warranty	



TERM	DESCRIPTION
SNC	<ul style="list-style-type: none"> • Swipe-N-Clean™ - The Only Credit Card Service for the Self Service Industry
PBC	<ul style="list-style-type: none"> • Push Button Controller
POSPBC	<ul style="list-style-type: none"> • Point of Sale - Push Button Controller
SNT	<ul style="list-style-type: none"> • Select-N-Touch - 10 Position easy to use Touch Pad with Time Remaining Display, Colorful Graphics and Indicator Lights
USE CODE	<ul style="list-style-type: none"> • The last four digits of the user credit card number followed by the pound (#) sign - Assigned by the Swipe-N-Clean unit.
CCP	<ul style="list-style-type: none"> • Credit Card Processor
ICVerify	<ul style="list-style-type: none"> • The Software used to connect you to the credit card processor, via your merchant code.

