



# Reverse Osmosis System

## *Installation/Operation Manual*



**COLEMAN  
HANNA**  
CARWASH SYSTEMS LLC

AN O'HANRAHAN COLEMAN COMPANY

5842 W 34th St • Houston, TX 77092

1.800.999.9878 1.713.683.9878

[www.colemanhanna.com](http://www.colemanhanna.com)



Find us on Facebook:  
[/ColemanHannaCarwash](https://www.facebook.com/ColemanHannaCarwash)



## REVERSE OSMOSIS SYSTEMS

### TABLE OF CONTENTS

R.O. SYSTEM DESCRIPTION .....	2
R.O. EQUIPMENT INSTALLATION.....	3
R.O. SYSTEM CHECK-OUT PROCEDURE .....	4
R.O. UNIT TURN ON PROCEDURE .....	5
R.O. UNIT RATING.....	6
R.O. BAY DELIVERY AND HOOK-UP.....	7
COMPUTER OPERATION DESCRIPTION.....	8
<i>PRODUCTION</i>	
<i>DELIVERY</i>	
<i>R.O. SIZE</i>	
R.O. PARTS.....	9-10
TROUBLE SHOOTING GUIDE.....	11
FLOAT SWITCH HOOK-UP.....	12
DRAWING OF FRONT OF R.O. SYSTEMS BOARD PANEL.....	13
DRAWING OF BACK OF R.O. SYSTEMS BOARD PANEL.....	14
PRESSURE BOOSTER PUMP installation instructions & parts list.....	15-26
SINGLE R.O. STAND .....	RO1.0



## SPARKLE REVERSE OSMOSIS UNIT

### System Description

The Sparkle Reverse Osmosis (Spot Free Rinse System) is engineered with the best available components on the market to deliver low pressure, spot free water to the car wash bays. The system can be installed on any existing car wash, as well as, new installations. Years of trouble free service, with little maintenance, can be expected. The following equipment is included in your Sparkle Reverse Osmosis Pumping and Storage Unit.

1. Product Water Storage Tank
2. Blue Charcoal Filter
3. Chlorine Test Kit
4. 10' 3/4" Product Hose
5. R.O. Owner's and Installation Manual.

The following should be installed for the R.O. Unit by its appropriate installer:

1. 220 Volt Single-Phase electricity, ground and other electrical hook-ups as required by local Electrical Codes and City Ordinances.
2. 1/2" (Use 1" for 3200 GPD or Above Units) Water Supply Line. This line should be taken off of the existing water softener to provide softened water to the R.O. Unit.

**NOTE:** If the water supplied to the R.O. Unit is 50° F, then hot and cold water must be blended together to provide a consistent water temperature between 70° and 90° F.

3. 1/2" Drain Line.
4. A clean floor and working space for the R.O. Unit and Product Storage Tank.



## SPARKLE REVERSE OSMOSIS UNIT EQUIPMENT INSTALLATION

1. Position fiberglass tank in equipment room as close the Super Saver as possible.

**NOTE: When installing tank, make sure that the area the tank is clean and free of dirt and debris, so as not to damage the Product Storage tank.**

2. Place blue charcoal filter between softened water supply and R.O. unit. Hook-up incoming water into the inlet side then turn on water supply and allow the unit to flush with water for at least 10 minutes or until water that is coming out of filter outlet that is clean and clear. Turn water supply off.
3. Install a 1/2" hose from the outlet side of the charcoal filter to the inlet hook-up on the R.O. unit. This connecting point is located on the back of the R.O. unit behind the 0-100 psi pressure gauge.
4. On the back of the R.O. unit control panel is a blue 3/8" hose that attaches to the top of the product storage tank. This hose provides a route for the spot-free water to get from the R.O. unit to the storage tank.
5. On the back of the R.O. unit control panel is a red 3/8" hose that goes to the 1/2" drain provided for the unit.

**NOTE: This water can be returned to the wash tank if desired.**

6. Inside the R.O. unit control box is a 4-conductor cable coming from the computer. This control cable goes to the float switch that is located in the product storage tank. The proper connection sequence is as follows:

**Red Lead ----- Lower Float Switch**  
**Green Lead ----- Upper Float Switch**  
**Black Lead ----- Upper and Lower Float**  
(See Appendix B)

7. Install 3/4" line between the outlet of the product storage tank (lower fitting) and the inlet side of the delivery pumps (elbow located on top of pump).



## SPARKLE REVERSE OSMOSIS UNIT CHECKOUT PROCEDURE

Before continuing installation, perform the following checks:

1. Turn on water supply valve and check for leaks of any kind. If any are found, turn off the valve, repair leak and retest. The water pressure should read between 20-60 psi, at the 0-100 psi gauge, depending on the city water pressure.
2. Perform chlorine test according to the instructions provided in the test kit. If any trace of yellow is found, re-check installation of charcoal filter for a reversed hook-up. Properly install charcoal filters, and retest. If the charcoal filter is properly installed and the chlorine test fails again then the charcoal filter is defective and must be replaced.

**<<< CAUTION HIGH VOLTAGE >>>**

3. Check electrical voltage at breaker and verify that 220 Volts single phase is provided to unit.
4. Check that drain hose has been connected from R.O. unit to drain.
5. Check to see if the "run" and "power" lights on the Omron computer are lit.



## REVERSE OSMOSIS UNIT TURN-ON PROCEDURE

Now that the Sparkle Reverse Osmosis Unit is installed, Spot Free water can be produced. Turn power on to the R.O. unit and it should start to produce SF water (Product Water). There should be a supply of water going to the Product storage tank and a small amount of water coming out of the drain hose (Reject Water). The pressure gauge on the front of the R.O. control panel will indicate the product supply pump pressure. It should read between 130-195 psi. The unit should run for several minutes, allowing air to escape the system.

Do not make any adjustments until the unit has been turned on for about 10-15 minutes. This unit was factory run and tested and should not need any adjustments, but if needed, proceed as follows:

To adjust the amount of Product Water or Reject Water adjust the regulator. The regulator is located in the middle of the R.O. control panel, for the supply pump. When the regulator is increased (turned clockwise) there will be less flow indicated on the reject flow meter and more flow on the product flow meter.

**NOTE: Never exceed 195 psi, or damage will occur to the R.O. Unit pump and membrane.**

To properly set the ratio of Product Water to reject water, adjust the regulator starting out at about 100 psi and increase the pressure in 10-psi increments. You will notice that, even though you keep increasing the pressure, the product water does not increase (only the reject water decreases). At this point, by increasing the pressure, you are only working the membranes harder and harder, but yet not producing any more water. A lot of systems run typically at 150-170 psi.



## SPARKLE REVERSE OSMOSIS UNIT RATINGS

Typical recovery rates and settings for a Sparkle R.O. System are as follows:

System Size	Product Water		Reject Water	
	Minimum GPM	Maximum GPM	Minimum GPM	Maximum GPM
500 GPD System	.2	.4	.8	1.0
1500 GPD System	.7	.9	1.4	1.5
3200 GPD System	1.6	2.6	3.0	3.5
4800 GPD System	2.5	3.0	4.0	4.5

Never exceed the above listed recovery rates or severe fouling will result and membrane warranty will be void. It is best and most economical to have a high rate of reject water, than to take a chance in damaging membranes by pushing the R.O. unit too hard.

If the unit is not producing the anticipated amount of product water, the following factors can usually be contributing to its failure:

- A. TDS (Total Dissolved Solids) above 300 PPM
- B. Water temperature is too cold
- C. Hard water

**Important Note: Once the product tank has about 2-3' of water, you will need to prime the delivery pump. To do this, simply loosen the hose fitting on the discharge side of the pump, allowing water and air to flow through the pump until all air is purged from the line.**

If there are any problems, questions, or concerns on setting up this unit contact the company, 1-800-999-9878 or 1-713-683-9878.



## SPARKLE REVERSE OSMOSIS UNIT BAY DELIVERY AND HOOK-UP

Now the R.O. Unit is producing Spot Free Water and it is time to hook-up the bay delivery system.

Install 3/8" poly-flow tubing from each solenoid on the R.O. Control Panel to the top of the 360 Degree boom in each bay. Install the brass check valves (provided) at the top of each boom so that the SF water will flow through the check valve, into the top of the boom, down the hose, and out the trigger gun or wand.

NOTE: This check valve must be installed. It prevents high pressure from backing up into the R.O. Unit.

**Do this for each bay connecting the #1 solenoid to the #1 solenoid to the #1 Bay, the #2 solenoid to the #2 Bay, etc. If the unit is mounted on the Super Saver, then the factory has already pre-wired the low voltage.**

Connect one conductor of a 2-conductor control cable from a 24 Volt Hot and the other conductor from a 24 Volt Common to terminals 1 and 2 on the R.O. Unit Control Box Terminal Strip. This hook up is for bay #1. Hook up each bay accordingly.

The rotary switch must be wired into the system, proving the 24 Volt hot to each bay when the selection is made according to the selection decal. Check the level of the poly-holding tank and verify that there is product water approximately 6" above the outlet fitting on the tank. Bleed the line between the delivery pump and the holding tank by loosening the hose fitting at the front end of the pump. When the air is purged out of the line and water is freely flowing re-tighten fitting snugly. The R.O. Unit is now ready for use.

Turn on a bay and there should be spot free water coming through the system. It is common for the SF water to take up to 60 Seconds before it comes out of the trigger gun or wand the first time. Continue to run each bay for several minutes to flush out all contaminants from the hoses and fittings. The pressure from the delivery pump is constant and un-adjustable. It should read from 150-190 PSI.

Again check for leaks and repair as needed. Close up the electrical panels and replace all covers.

Make sure the test switch located in front of the R.O. Unit control box is in the off position. This will allow the unit to automatically shut off when the fiberglass-holding tank is full. The test switch is used to by pass the tank switches so that the operator can verify that the system is working. The by-pass switch is not provided on the Super Saver unit; only the freestanding unit.





## AUTOMATIC HOOK UP

You will need to run two wires from the R.O. Electrical Panel to the Water Wizard "Electrical Control Center". On "Term 2", on the water wizard panel, you will find two terminals marked "Spot-Free". Connect one wire to each of these terminals. On the R.O. Electrical panel connect one wire to input # 010 on the OMRON computer and the other wire to 24 VOLT AC hot common on the output side of the OMRON computer. If you have two water wizards, use input #011 for the second one. All other wires are connected the same.

## COMPUTER OPERATION DESCRIPTION

### PRODUCTION

Computer receives a signal from upper float switch that tank is low on water. If signal is present over 10 seconds the computer will turn on water solenoid valve to production pump. After 10 seconds the computer then determines that if the water pressure is above 20 PSI, to turn on the production pump motor starter. If at any time the computer does not receive a signal from the pressure switch that water pressure is above 20 PSI, then the computer will flash output 107 and turn off the production pump.

### DELIVERY

When the computer receives a 24V signal from any bays (inputs 4-11), it has a one second delay in turning on the delivery pump motor starter. If at anytime the computer receives a signal from low water cut off that the poly tank is empty the computer will shut down the delivery pump and flash output 106.

Power and the run light on the Omron computer must be on for the computer to function properly.

### REVERSE OSMOSIS SIZE

**To determine what size your R.O. Unit is, simply measure the membranes mounted on the unit.**

- If the membrane is 2 ½" x 40" it is capable of producing 500 gallons per day.
- If the membrane is 4"x40" the unit is capable of producing 1600 gallons per day.
- If the membrane is (2) 4"x40" the unit is capable of producing 3200 gallons per day.
- If the membrane is (3) 4"x40" the unit is capable of 4800 gallons per day and so on.



### REVERSE OSMOSIS PARTS LIST

ITEM	PART #	DESCRIPTION
1	47030	.2-2.0 GPM Flow Meter
	47040	.1-1.0 GPM Flow Meter
	47044	.5-5.0 GPM Flow Meter
	47048	1.0-10.0 GPM Flow Meter
3	47010	0-300 PSI Panel-Mount Gauge
4	58020	Pressure Regulator
5	64070	24V ½ Solenoid Valve
6	47011	0-300 PSI Lower-Mount Pressure Gauge
8	64019	Two-Stage Solenoid
	64021	Three-Stage Solenoid
	64023	Four-Stage Solenoid
9	64026	24V Solenoid Coil
10		¼ MPT x 3/8 Poly Flow Tubing Fitting
11	22164	¼ HEX Nipple
12	22052	¼ ST ELL
13	22228	3/8 Hose Fitting Swivel
14		3/8 MP x 3/8 Flare X 90 °
15	22046	3/8 Elbow
16	22200	38 ST Tee
17	22102	3/8 x ½ Bushing
18	64002	½ Solenoid Valve
19	22216	½ MPT x 3/8 Flare
20	22218	½ MPT x ½ Hose Barb
22	34020	3/8 Check Valve
21		3/8 MPT x 3/8 Flare
22	222212	3/8 MP x 3/8 Hose Barb
23	22046	3/8 Elbow
24	22226	¼ Hose Barb Swivel
25		¼ FPT x ¼ Flare x 90°
26		¼ MPT x ¼ Flare x 90°
27	22088	¼ x 3/8 Bushing
28	22102	½ x 3/8 Bushing
29	22176	½ x 3/8 Bushing
30	62130	Reverse Osmosis Membrane AKA-500 2 ½" x 4
	62130-1	Reverse Osmosis Element for AKA-500
	62130-2	Reverse Osmosis Housing AKA-500
	62132	Reverse Osmosis Membrane AKA-1600 4"x 40
	62132-2	Reverse Osmosis Element for AKA-1600
31	22084	½ MPT x ½ FPT Coupling
32		½ MPT x ½ Flare x 90°
34	57002	Procon Pump For 500 GPD Reverse Osmosis
	57030	Procon Pump for 1600 GPD Reverse Osmosis



ITEM	PART #	DESCRIPTION
35	22056	1/2 ST Ell
37	22172	1/2 Hex Nipple
39	22166	3/8 x 1/4 Hex Nipple
40		Pressure Switch Reverse Action 69WR5
41	66004	3/8 Filter Housing
	66034	3/4 Filter
42	57050	PB-10 Pump
43	22108	3/4 x 1/2 Bushing
ITEMS	PART #	DESCRIPTION
NOT	33460	Omron Controller (may vary with unit size)
SHOWN	66054	2 Cubic Feet Charcoal Filter
	66064	Bag Charcoal 2 Cubic Feet

FRONT OF R.O. SYSTEM BOARD PANEL

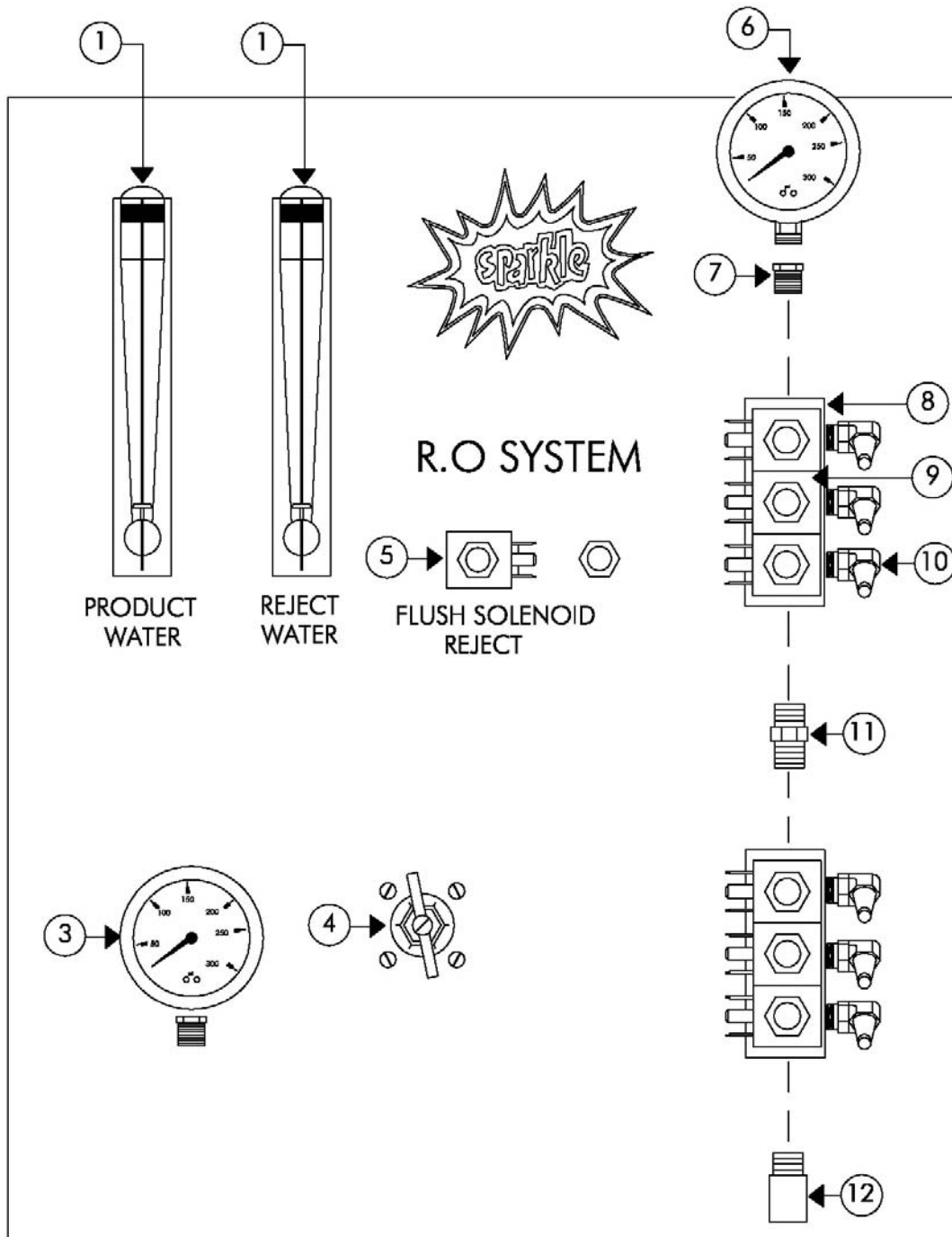

## BACK OF R.O. SYSTEM BOARD PANEL

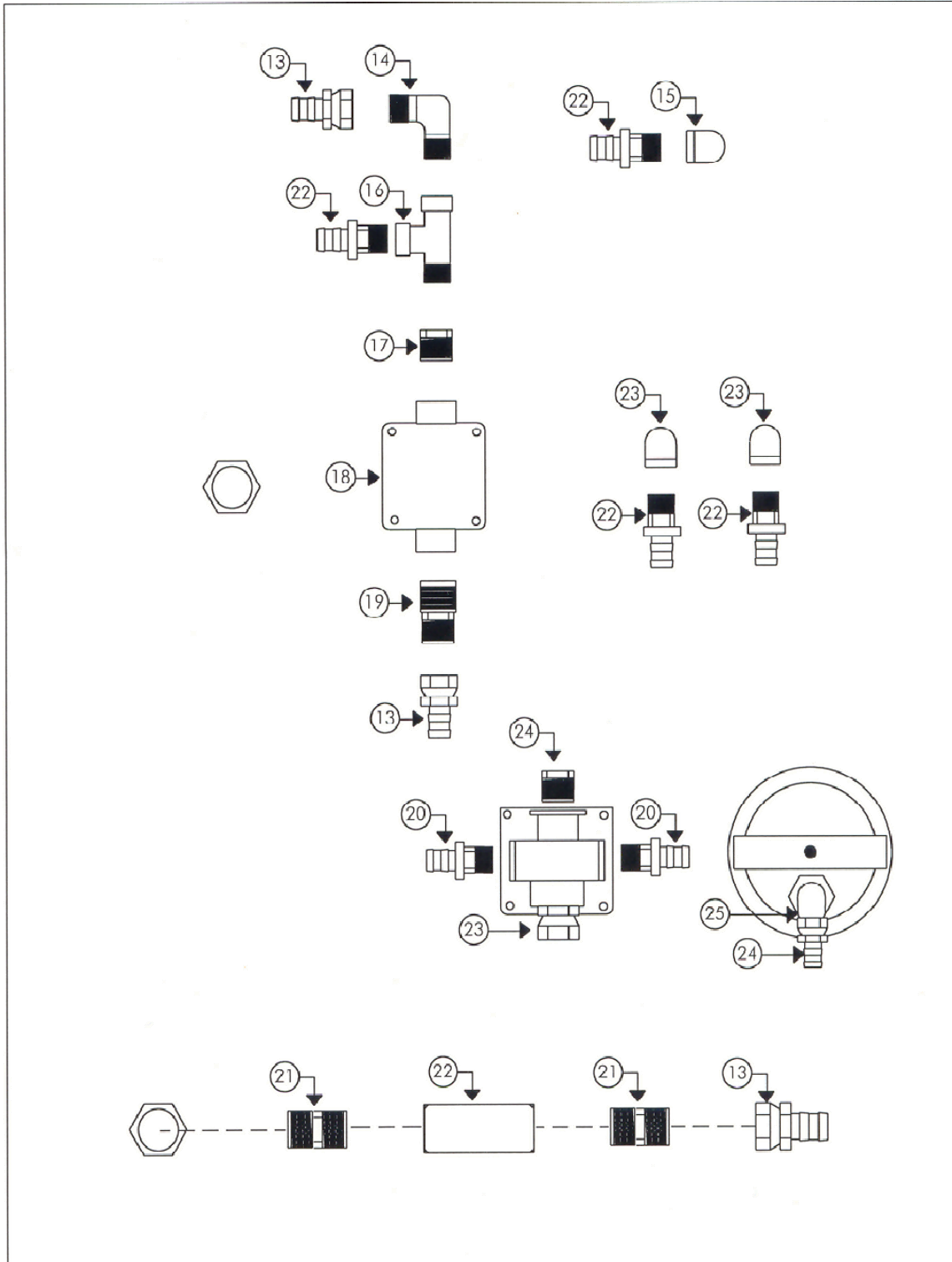



## TROUBLE SHOOTING GUIDE

NO.	INPUTS	LIGHTS	LIGHT OPERATION
0000	Water Pressure Switch	On	Turns off when pressure is low
0001	Low Water Switch	Off	Turns on when Tank Runs Empty
0002	Upper Water Switch	Off	Turns on When Tank is Low on Water
0003	Program for High TDS	Off	Changes Program to Flush More
0004	Bay 1 Input	Off	Turns on When Bay 1 is on SF
0005	Bay 2 Input	Off	Turns on When Bay 2 is on SF
0006	Bay 3 Input	Off	Turns on When Bay 3 is on S
0007	Bay 4 Input	Off	Turns on When Bay 4 is on S
0008	Bay 5 Input	Off	Turns on When Bay 5 is on S
0009	Bay 6 Input	Off	Turns on When Bay 6 is on S
0010	Bay 7 or Auto 1	Off	Turns on When Bay 7 is on S
0011	Bay 8 or Auto 2 Input	Off	Turns on When Bay 8 is on S
	OUTPUTS	LIGHTS	LIGHT OPERATION
100	Self Serve Delivery Pump	Off	Turns on When Bay 1-8 is on SF
101	Water Solenoid	Off	Turns on to Feed Production Pump
102	Production Pump	Off	Turns on Refill Tank
103	Flush Solenoid	Off	Turns on to Flush Membranes
104	Auto #1 Delivery Pump	Off	Turns on When Auto 1 Calls for SF
105	Auto #2 Delivery Pump	Off	Turns on When Auto 2 Calls for SF
106	Flashing Low Water Light	Off	Flashes When Tank is Empty
107	Flashing Low Press. Light	Off	Flashes When Water Pressure is Low

FLOAT SWITCH HOOK-UP

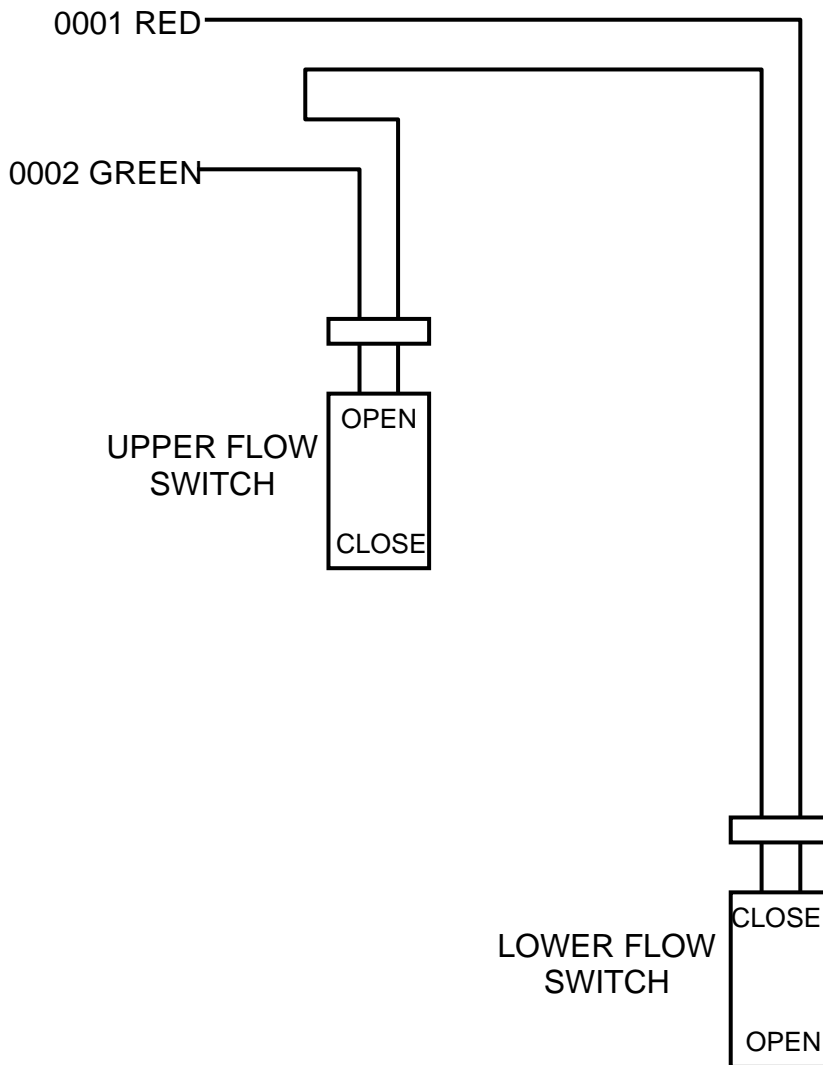

# **STA-RITE®**

## **OWNER'S MANUAL**

INSTALLATION AND OPERATING INSTRUCTIONS  
REPAIR PARTS LIST

**Signature 2000  
High Pressure Booster Pump  
60 Hz. 1/2 through 2 HP**

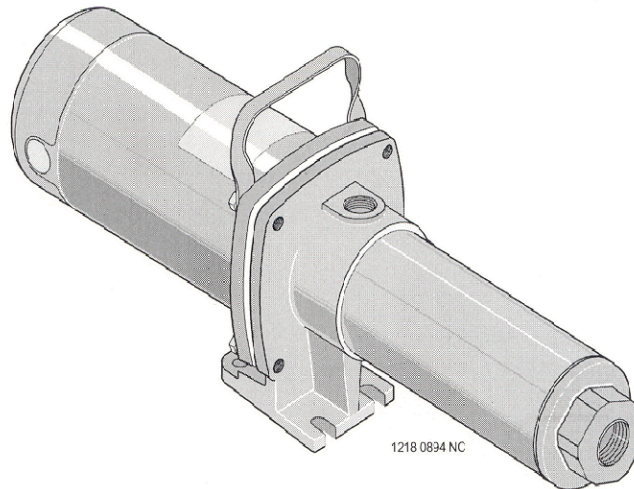

**STA-RITE INDUSTRIES, INC., DELAVAN, WISCONSIN 53115**

Printed in U.S.A. © 2001, Sta-Rite Industries, Inc.

S327 (Rev. 4/27/01)





**⚠ DANGER**

**⚠ WARNING**

**⚠ CAUTION**

**ELECTRICAL SAFETY**

**⚠ WARNING**



Hazardous voltage. Can shock, burn, or cause death.

Ground pump before connecting to power supply.

**⚠** Some models of pump are supplied with 3-connector grounding type cord. Connect only to properly grounded, GFCI protected outlet. Do not lift pump by electrical cord.

**⚠** Pump is non-submersible. Keep motor dry at all times. Do not wash motor. Do not immerse. Protect motor from wet weather.

**⚠** If using extension cord, use only UL approved indoor/outdoor,

3-wire, grounding type cord. Do not allow any part of cord or receptacle ends to sit in water or damp locations.

**⚠** Unplug pump before servicing.

**⚠ CAUTION** Burn Hazard. Do not touch an operating motor. Modern motors are designed to operate at high temperatures. To avoid burns when servicing pump, allow it to cool for 20 minutes after shut-down before handling.

Follow local and/or national plumbing and electrical codes when installing.

**⚠ WARNING** Hazardous Pressure. **DO NOT** run the pump with discharge shutoff, as hose may burst or pump may be damaged due to high temperatures.

**READ AND FOLLOW SAFETY INSTRUCTIONS!**

This is the safety alert symbol. When you see this symbol on your pump or in this manual, look for one of the following signal words and be alert to the potential for personal injury:

**DANGER** warns about hazards that will cause serious personal injury, death or major property damage if ignored.

**WARNING** warns about hazards that can cause serious personal injury, death or major property damage if ignored.

**CAUTION** warns about hazards that will or can cause minor personal injury or property damage if ignored.

The word **NOTICE** indicates special instructions which are important but not related to hazards.

**GENERAL SAFETY**

To avoid risk of serious bodily injury and property damage, read safety instructions carefully before installing pump.

Do not allow pump or any system component to freeze. To do so may damage system and will void warranty.

**⚠ WARNING** Risk of electric shock. To avoid fatal shocks, proceed as follows if pump needs servicing.

- A. Disconnect power to pump outlet box before pulling pump cord plug. After plug is pulled, let pump cool for 20 minutes before attempting to work on it.
- B. Take extreme care when changing fuses. To reduced chance of fatal electrical shocks, **DO NOT** stand in water or put your finger in the fuse socket.
- C. Ground electrical outlet box.
- D. Use only Ground Fault Circuit Interrupter (GFCI) protected grounded outlet for cord plug.

Never run pump dry. Running pump dry can damage internal parts, overheat pump (which can cause burns to people handling or servicing pump), and will void warranty.

Do not pump chemicals or corrosive liquids with pump.

**⚠ WARNING** Hazardous Pressure.

- A. Use high pressure reinforced type discharge hose **ONLY**. See parts list for available hose, nozzle and fittings. A high pressure relief valve is recommended.
- B. **DO NOT** use garden hose with High Pressure Booster pump. Garden hose will not stand the discharge pressure produced and will fail.
- C. High pressure discharge stream is dangerous. To avoid injury, **DO NOT** aim the discharge stream at any person or animal.
- D. **BE SURE** that the pump suction pipe pressure plus the pump discharge pressure does not exceed the pressure rating of hose and fittings. See Table I for pump discharge pressure ratings.

### INSPECT THE SHIPMENT

The high pressure booster pump has been carefully inspected and packaged to assure safe delivery. Inspect the pump and fittings and report to the carrier any items which are damaged or missing.

Model	HP	Phase	Avg. GPM
HP7C-02, HPS7C-01	1/2	1	7
HP7C3-02, HPS7C3-01	1/2	3	7
HP7D-02, HPS7D-01	3/4	1	7
HP7D3-02, HPS7D3-01	3/4	3	7
HP7E-02, HPS7E-01	1	1	7
HP7E3-02, HPS7E3-01	1	3	7
HP10C-02, HPS10C-01	1/2	1	10
HP10C3-02, HPS10C3-01	1/2	3	10
HP10D-02, HPS10D-01	3/4	1	10
HP10D3-02, HP10D3-01	3/4	3	10
HP10E-02, HPS10E-01	1	1	10
HP10E3-02, HPS10E3-01	1	3	10
HP10F-02, HPS10F-01	1-1/2	1	10
HP10F3-02, HPS10F3-01	1-1/2	3	10
HP10G-02, HPS10G-01	2	1	10
HP10G3-02, HPS10G3-01	2	3	10
HP20E-01, HPS20E-01	1	1	20
HP20E3-01, HPS20E3-01	1	3	20
HP20F-01, HPS20F-01	1-1/2	1	20
HP20F3-01, HPS20F3-01	1-1/2	3	20
HP20G-01, HPS20G-01	2	1	20
HP20G3-01, HPS20G3-01	2	3	20

\*The "S" in the Model Number indicates a stainless steel pump body, a stainless steel discharge assembly and stainless steel capscrews.

**TABLE I - DISCHARGE PRESSURE**

GPM	HP	No. of Stages	Discharge Pressure PSI at Rated Flow	Discharge Pressure PSI at No Flow
7	1/2	9	90	130
7	3/4	12	123	173
7	1	16	162	229
10	1/2	6	74	113
10	3/4	8	97	147
10	1	10	134	188
10	1-1/2	14	173	206
10	2	16	197	260
20	1	7	275	110
20	1-1/2	9	97	143
20	2	11	123	175

\*For total discharge pressure, add this pressure to suction pipe pressure. For example, an HP7C pump taking suction from a 100 psi water service line will produce 130 + 100 = 230 psi total discharge pressure at 0 GPM flow. If suction pressure drops to 50 psi, discharge pressure will drop to 180 psi.

**NOTE:** Model numbers that include an "S" (HPS7C, HPS10D, etc) are identical to models listed above, except that they have a stainless steel suction, discharge assembly, and capscrews. Model numbers ending in 3 (HP7C3, HPS10C3, etc) have 3-phase motors.

### INSTALLATION

The pump is designed to boost city water pressure or water pressure from a private water system. Use this high pressure stream to wash down milk parlors, barns, garages and driveways, or for fire protection.

The pump is portable with a convenient carrying handle. If an existing pressure water system is to be used as a water supply, it can be connected with available fittings and 3/4" or 1" high pressure hose to the pump inlet. A special heavy duty 3/4" or 1" suction hose with fittings is available as an accessory. If pump is permanently mounted on wall, use a 3/4" or 1" pipe or heavy-duty hose for suction line. 20 GPM models require one-inch discharge hose to reduce friction losses.

**⚠ WARNING Hazardous pressure. Pump body may explode if pressures exceed rated limits.** Maximum inlet pressure is 80 PSI. Maximum discharge pressure is 315 PSI. Warranty is void if these pressure limits are exceeded.

### HIGH PRESSURE BOOSTER PUMP INSTALLATION INSTRUCTIONS

These instructions cover high pressure booster pump installations as shown below:

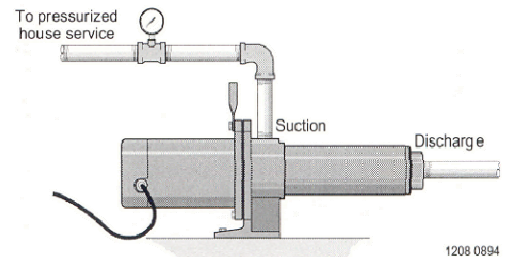

Figure 1 – Connection to house service.

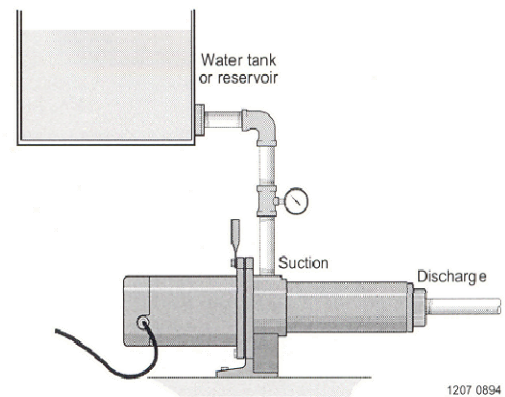

Figure 2 – Connection to water reservoir.

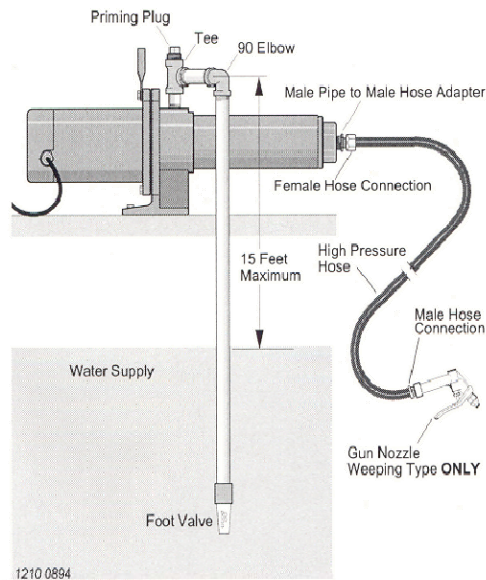

Figure 3 – Cistern or shallow well installation.

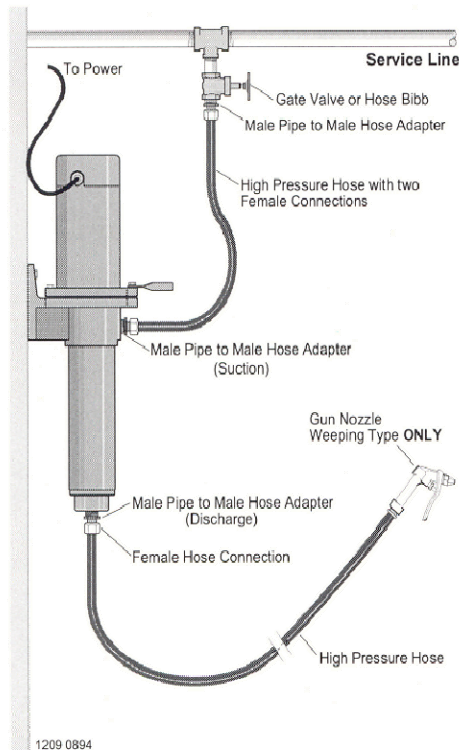

Figure 4 – Wall mounted to pressurized service line.

To reduce friction losses to a minimum, inlet (suction) line should be **short** and have as few elbows as possible.

Size the inlet according to the chart below:

Ave. GPM	Threaded Inlet Size	Recommended Inlet Line Size	Recommended Discharge Line Size
7	3/4" NPT	1"	1"
10	3/4" NPT	1"	1"
20	1" NPT	1-1/4"	1-1/4"

An inlet strainer will prevent suspended debris from clogging pump.

The internal running surfaces of the pump and seals require water lubrication for good, consistent operation. **Allowing pump to run dry will severely damage pump and seals.**

Install a pressure gauge in pump inlet line. Keep at least two pounds per square inch pressure (2 PSI) in inlet line whenever pump is operating. If this is not possible, consult customer service representative.

## LUBRICATION

It is not necessary to lubricate pump or motor. The motor is equipped with sealed ball bearings, lubricated for the life of the bearing. The mechanical shaft seal in the pump is self-lubricating and requires no adjustment. Disassemble pump to replace seal (See "Maintenance", Pages 7 and 8).

## OPERATION

**NOTICE:** Observe the following precautions when operating the pump:

1. **Keep the motor dry! Do not** direct stream from pump discharge onto the motor!
2. **⚠ WARNING Hazardous pressure. Do not** run the pump with discharge shutoff, as hose may burst or pump may be damaged due to high temperatures.
3. **Do not** use a standard trigger gun with this pump. Use only trigger guns with an automatic weeping feature. These are available as accessories and are provided with three nozzles. The smallest nozzle restricts the flow, allowing use of a smaller water source. The two larger nozzles are used if the water source will supply the pump's full capacity.
4. **Do not** run pump dry; to do so may damage the seal.
5. To avoid internal damage to pump, **Do not** operate with water temperature above 175 degrees F.

**⚠ Disconnect power before working on pump, motor, pressure switch, or wiring.**

### Single Phase

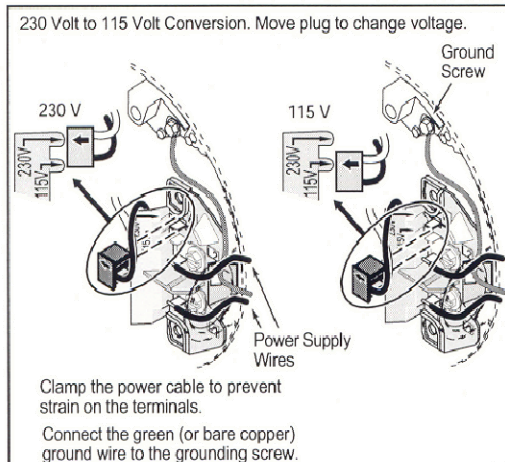

Figure 5: Motor wiring connection, Plug-in

### Single Phase

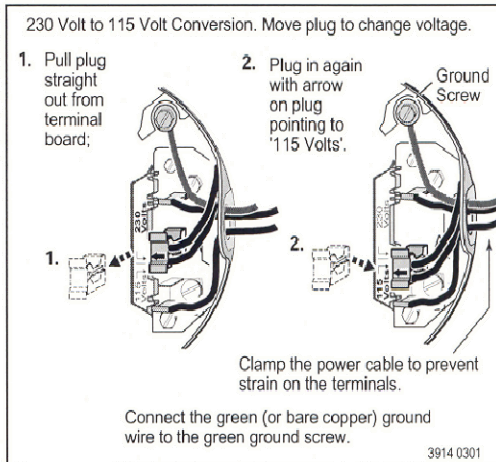

Figure 6: Motor wiring connection, Spade Connector

## ELECTRICAL

- ⚠ Ground motor before connecting to electrical power supply.**
- ⚠ Failure to ground motor can cause severe or fatal electrical shock hazard.**
- ⚠ Explosion hazard. Do not ground to a gas supply line.**
- ⚠ To avoid dangerous or fatal electrical shock, turn OFF power to motor before working on electrical connections.**
- ⚠ Supply voltage must be within  $\pm 10\%$  of nameplate voltage. Incorrect voltage can cause fire or serious damage to motor and voids warranty. If in doubt consult a licensed electrician.**
- ⚠ Use wire size specified in Wiring Chart (Table II, Page 6). If possible, connect pump to a separate branch circuit with no other appliances on it.**
- ⚠ Wire motor according to diagram on motor nameplate. If nameplate diagram differs from diagrams above, follow nameplate diagram.**

**For All 3-phase Motors:** Follow the wiring diagram on the motor junction box or on the motor nameplate.

## WIRING CONNECTIONS

1. Install, ground, wire and maintain this pump in compliance with the National Electrical Code (NEC) or the Canadian Electrical Code (CEC) and with all local codes and ordinances that apply. Consult your local building inspector for local information.
2. Make sure that the voltage, frequency and phase (single phase or three phase) of the power supply agree with that stamped on the motor nameplate. If

in doubt, check with the power company.

3. Some models are equipped with three phase motors. Three phase motors require magnetic starters and can run in either direction, depending on how they are connected to the power supply.

**NOTICE:** Dual voltage motors are factory wired for 230 volts. If necessary, reconnect the motor for 115 volts, as shown. Do not alter the wiring in single voltage motors.

Install, ground, wire, and maintain your pump in compliance with the National Electrical Code (NEC) or the Canadian Electrical Code (CEC), as applicable, and with all local codes and ordinances that apply. Consult your local building inspector for code information.

**NOTICE:** Clamp the power cable to prevent strain on the terminal screws.

**NOTICE:** Your Motor Terminal Board (under the motor end cover) looks like one of those shown above. Do not change motor wiring if line voltage is 230 volts. Connect power supply as shown for your supply voltage.

**To Convert from 230 Volts to 115 Volts, Spade Connector type (see Figure 6).**

1. Unplug the motor.
2. Loosen the two screws on the end of the motor. Gently pull the canopy from the motor.  
**NOTICE:** Do not pull or jerk wires.
3. Connect the green (or bare copper) ground wire to the green ground screw first (see Figure 5). Use a solid copper wire at least as large as the power supply wires.
4. Move the white wire with black tracer from the "B" position to the "A" position on the terminal board.
5. Move the BLACK wire from the "A" position to the "L1" position on the terminal board.
6. Change is complete.

**To Convert 230 Volts to 115 Volts, Plug-in type (see Figure 5).**

1. Unplug the motor.
2. Loosen the two screws on the end of the motor. Gently pull the canopy from the motor.  
**NOTICE:** Do not pull or jerk wires.
3. Connect the green (or bare copper) ground wire to the green ground screw first (see Figure 6). Use a solid copper wire at least as large as the power supply wires.
4. Pull the plug straight out from the terminal board, from 230 Volt socket (Figure 5).
5. Plug in again with arrow on plug pointing to 115 Volts.
6. Change is complete.

**NOTICE:** Some models are equipped with three phase motors. Three phase motors require magnetic starters and can run in either direction, depending on how they are connected to the power supply.

**To Check For Proper Rotation – 3 Phase Motors**

**⚠ WARNING Risk of electrical shock.**

1. Be sure power is disconnected to motor when working on electrical connections.
2. Remove the motor end cover, exposing motor shaft. Momentarily start pump. If hookup is correct, the shaft will rotate clockwise.
3. If rotation is not clockwise, reverse any two leads to the starter. The rotation will now be correct.

**GROUNDING THE MOTOR**

Ground the pump permanently using a wire of size and type specified by local or National Electrical Code.

**Models (HP7C-01 and HP7D Series Only) with factory installed cord and plug:**

**⚠ WARNING Risk of electric shock.** This equipment is only for use on 115V and is equipped with an approved 3-conductor cord and 3-prong, grounding-type plug. To reduce the risk of electric shock, be certain that it is connected to a properly grounded, grounding-type receptacle. Do not modify or remove plug. Make sure pump circuit meets National Electrical Code. To avoid dangerous electrical shock hazard, keep cord dry at all times.

**Models without cord and plug:**

1. Connect ground wire first. Connect the ground first, then to green grounding terminal provided under motor canopy (see Figure 5) identified as GRD. Make ground connection to this terminal. **Do not** connect motor to electrical power supply until unit is permanently grounded; otherwise serious or fatal electrical shock hazard may be caused.
2. For best ground connection, connect to a grounded lead in the service panel or to a metal underground water pipe or well casing at least 10 ft. long. If plastic pipe or insulated fittings are used, run ground wire directly to the metal well casing or use ground electrode furnished by the power company.

**MAINTENANCE**

**Pump Disassembly**

**⚠ WARNING Hazardous voltage.** Can shock, burn or cause death. Disconnect power to pump before servicing.

Tools required:

1. 7/16" open end wrench (2 required).
2. Flat blade screwdriver with insulated handle.
3. Work bench with vise recommended.
4. Pliers or similar tool.
5. Pipe wrench.

**TABLE II - RECOMMENDED FUSING AND WIRING**

Motor H.P.	Volts/Phase	Max. Load Amps	Branch Fuse Rating Amps	Wire Length			
				0'-50'	51-100'	101-200'	201-300'
				AWG Wire Size			
1/2	115/230/1	12.4/6.2	20/15	12/14	12/14	10/14	8/14
1/2	230/460/3	3.1/1.55	15/15	14/14	14/14	14/14	14/14
3/4	115/230/1	14.8/7.4	20/15	12/14	12/14	8/14	6/14
3/4	230/460/3	3.6/1.8	15/15	14/14	14/14	14/14	14/14
1	115/230/1	19.2/9.6	25/15	10/14	10/14	8/14	6/12
1	230/460/3	4.7/2.35	15/15	14/14	14/14	14/14	14/14
1-1/2	230/1	12.0	15	14	14	14	12
1-1/2	230/460/3	6.8/3.4	15/15	14/14	14/14	14/14	14/14
2	230/1	10.4	15	14	14	14	14
2	230/460/3	6.0/3.0	15/15	14/14	14/14	14/14	14/14

**Impeller Stack Changeout (See Figure 7)**

Remove pump from service and mount vertically in vise (if available) motor side down. Hold at center of motor. It may be desirable to wrap motor with a shop rag to protect outside surface.

Proceed as follows:

1. Attach pipe wrench to flats on discharge connection and turn clockwise to remove (left hand threads).
2. Remove screws holding motor canopy and remove canopy. Pull straight off as shown. Leave switch wires attached (if present).

**⚠ WARNING** Capacitor voltage may be hazardous. To discharge capacitor, hold insulated handle screwdriver **by the handle** and short capacitor terminals together. Do not touch metal screwdriver blade or capacitor terminals.

3. Unscrew capacitor clamp and remove capacitor. Do not disconnect capacitor wires. Slide 7/16" open end wrench in behind spring loaded centrifugal switch as

shown. Place on motor shaft flats to hold shaft stationary.

4. With one 7/16" wrench in place on motor shaft, place second wrench on shaft hex at pump end and unscrew impeller stack by turning counter-clockwise.
5. Once loose from motor shaft, hold shaft by snap ring using a pliers or similar tool, and pull stack from shell. You may have to apply a back and forth motion to break stack loose from shell.

To assemble with replacement impeller stack, keep pump in the vertical position, motor down, and reverse instructions 1 through 5.

Assembly hints:

- A. Apply a soapy water solution to suction and discharge O-Rings to ease seating of shell.
- B. Make sure mechanical shaft seal spring is in proper position on motor shaft.
- C. On three-phase models, apply Loctite No. 271 to motor shaft threads before reinstalling stack.

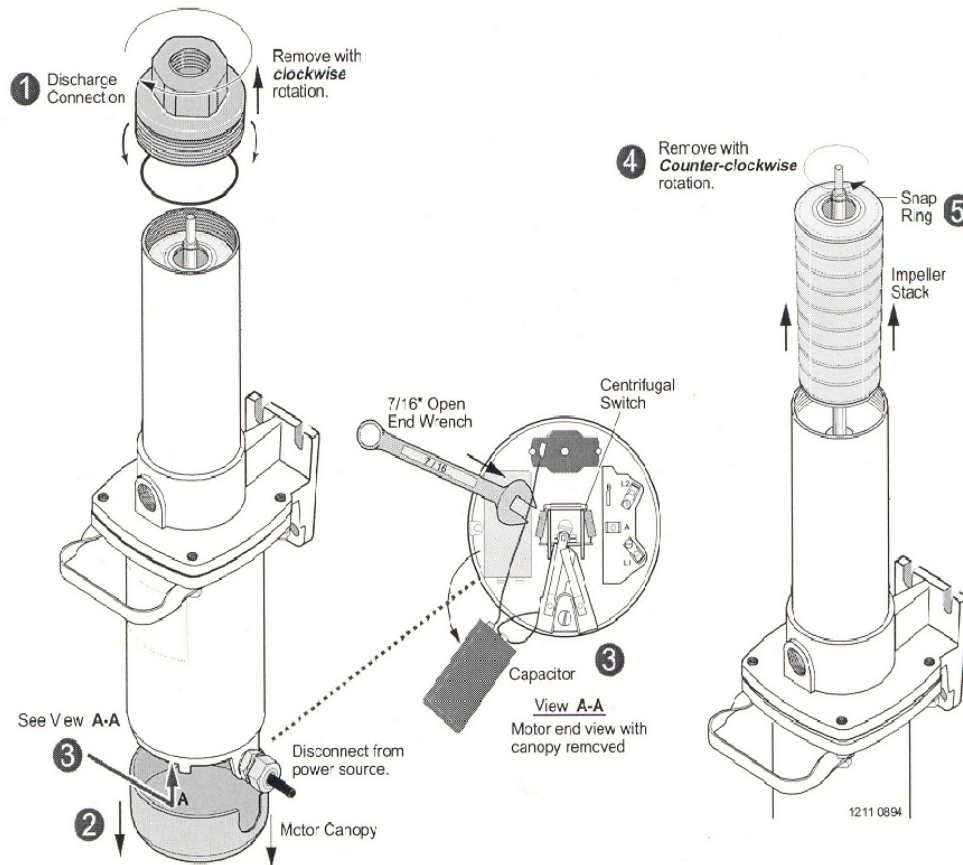

Figure 7 – Impeller stack changeout.

**Mechanical Seal Changeout**

(refer to Figures 7 and 8)

This procedure is best completed with the pump held in a vertical position, motor down.

First complete "Disassembly" instructions 1 through 5 under "Impeller Stack Changeout." (see Figure 7).

6. Remove 4 capscrews holding pump body to motor. Pump handle will come off with top capscrews.
7. Unscrew pump shell from pump body, turning clockwise (left hand threads).
8. Remove mechanical shaft seal spring and rotating half from motor shaft. Use care not to scratch motor shaft when removing rotating half.
9. Remove pump body from motor and place on flat surface, face down. Again, use care not to scratch motor shaft.
10. Use a screwdriver to push ceramic seat out from seal cavity as shown.
11. Installation of ceramic seat:
  - A. Turn pump body over so seal cavity is up; clean cavity thoroughly.
  - B. Clean polished surface of ceramic seat with a clean cloth.
  - C. Lubricate outside rubber surface of seat with soapy water. Place cardboard washer over

polished face of seat and press into seal cavity using a 3/4" socket or a piece of 3/4" standard pipe.

- D. Be sure polished surface of seat is free of dirt and has not been damaged by insertion. Remove excess soapy water. Dispose of cardboard washer.
12. Installation of rotating half and spring:
    - A. Reinstall pump body on motor using extreme caution not to hit ceramic portion of seal on motor shaft. Reattach pump body to motor using capscrews. Be sure to reinstall pump handle at this time.
    - B. Inspect shaft to make sure that it is clean.
    - C. Clean face of rotating half of seal with a clean cloth.
    - D. Lubricate inside diameter of rotating half with soapy water and slide onto motor shaft (sealing face first).
    - E. Place spring over motor shaft so it rests on rotating half.
  13. To complete reassembly from this point, reverse instructions 1 through 5 under "Impeller Stack Changeout."

**NOTICE:** Lubricate suction and discharge O-Rings with soapy water for easier installation of shell.

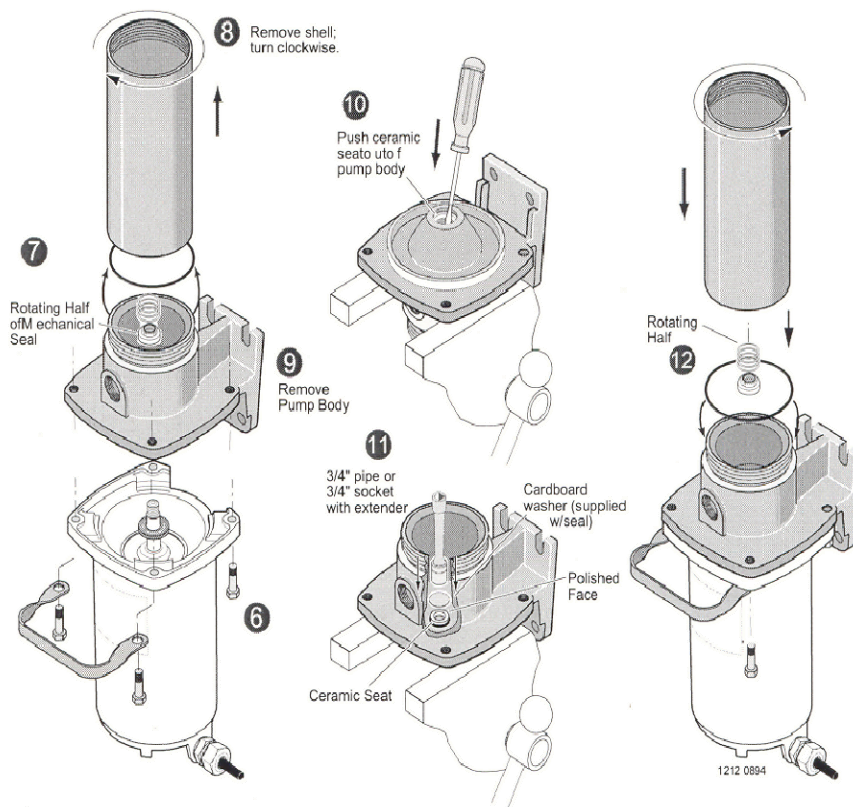
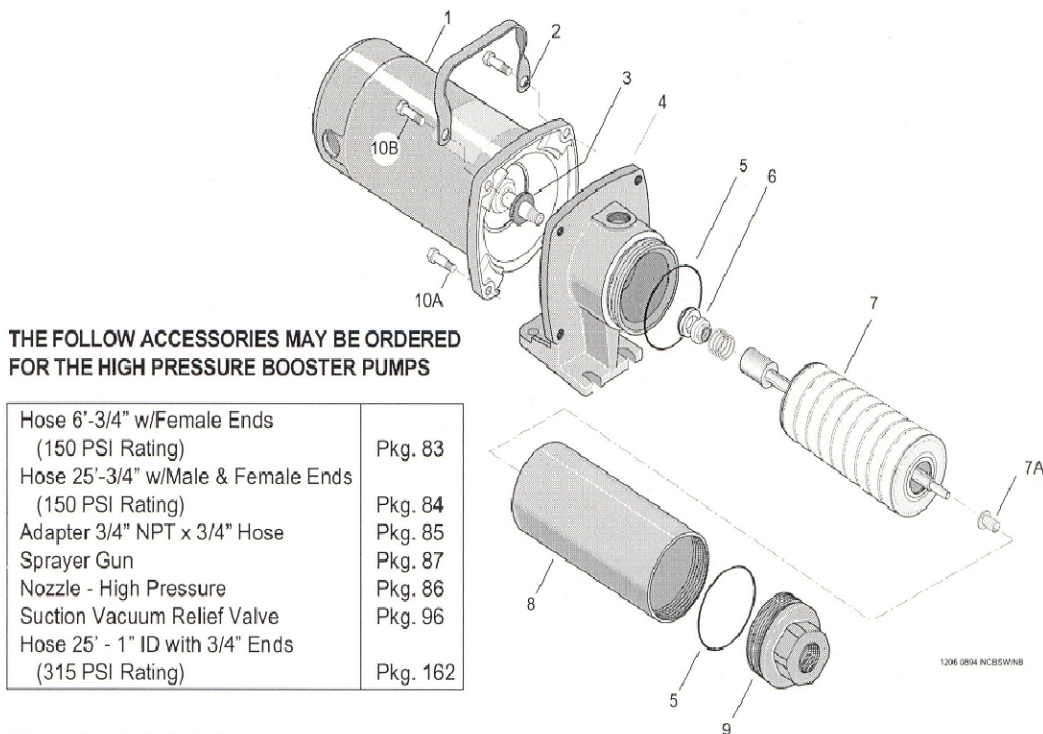

Figure 8 – Mechanical seal changeout.



**THE FOLLOW ACCESSORIES MAY BE ORDERED FOR THE HIGH PRESSURE BOOSTER PUMPS**

Hose 6'-3/4" w/Female Ends (150 PSI Rating)	Pkg. 83
Hose 25'-3/4" w/Male & Female Ends (150 PSI Rating)	Pkg. 84
Adapter 3/4" NPT x 3/4" Hose	Pkg. 85
Sprayer Gun	Pkg. 87
Nozzle - High Pressure	Pkg. 86
Suction Vacuum Relief Valve	Pkg. 96
Hose 25' - 1" ID with 3/4" Ends (315 PSI Rating)	Pkg. 162

Figure 8 – Exploded view.

**REPAIR PARTS LIST** (See Page 11 for HP20 Series Repair Parts)

Key No.	Description	Qty.	HP7C-02	HP7D-02	HP7E-02	HP10F-02	HP10G-02
			HP7C3-02	HP7D3-02	HP7E3-02		HP10G3-02
			HP10C-02	HP10D-02	HP10E-02	HP10F3-02	HP10G3-02
			1/2 HP	3/4 HP	1 HP	1-1/2 HP	2 HP
1	Motor - 115/230 Volt, 1 Phase	1	A100DHL	J218-955C	J218-601A	A100GSL	AE100G5L
1	Motor - 230/460 Volt, 3 Phase	1	AP100CH	AP100DL2	AP100EH	AP100FHP	AP100GH
2	Handle (†)	1	C54-21	C54-21	C54-21	-	-
3	Water Slinger	1	17351-0009	17351-0009	17351-0009	17351-0009	17351-0009
4	Pump Body	1	C2-85	C2-85	C2-85	C2-85	C2-85
5	O-Ring	2	U9-430	U9-430	U9-430	U9-430	U9-430
6	Shaft Seal Assembly	1	U9-118	U9-118	U9-118	U9-118	U9-118
7	Pump Stack (7 GPM Pump)	1	P325-422	P325-423	P325-424	-	-
7	Pump Stack (10 GPM Pump)	1	P325-425	P325-426	P325-439	P325-428	P325-429
7A	Nylatron Bearing (included with Key No. 8)	1	W31112	W31112	W31112	W31112	W31112
8	Pump Shell (7 GPM Pump)†	1	P56-430SSL	P56-431SSL	P56-432SSL	-	-
8	Pump Shell (10 GPM Pump)	1	P56-460SSL	P56-461SSL	P56-469SSL	P56-452SSL	P56-432SSL
9	Discharge Assembly	1	C152-3	C152-3	C152-3	C152-3	C152-4
10A	Capscrew - 3/8 x 16 x 1-1/4**	2	U30-75ZP	U30-75ZP	U30-75ZP	U30-75ZP	U30-75ZP
10B	Capscrew - 3/8 x 16 x 1-1/2"	2	U30-76ZP	U30-76ZP	U30-76ZP	-	-
#	Cord Connector**	1	U71-7	U71-7	-	-	-
#	Cord**	1	U17-402	U17-1238	-	-	-

\* All 10 GPM pumps use (4) U30-75ZP capscrews.

† Handle comes with HP7 series and HP10E series.

\*\* Included with Model Numbers HP7C-01 and the HP7D Series Model Numbers.

# Not Illustrated.



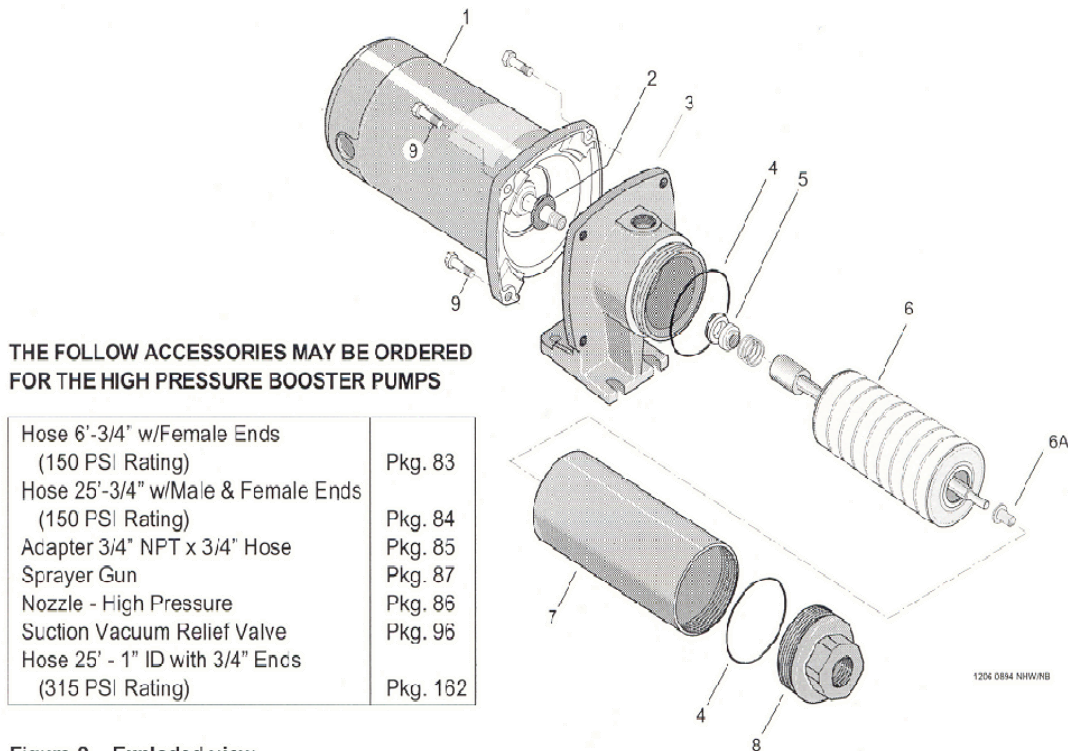

Figure 9 – Exploded view.

**REPAIR PARTS LIST** (See Page 11 for HPS20 Series Repair Parts)

Key No.	Description	Qty.	HPS7C-01	HPS7D-01	HPS7E-01	HPS10F-01	HPS10G-01
			HPS7C3-01	HPS7D3-01	HPS7E3-01		
			HPS10C-01	HPS10D-01	HPS10E-01	HPS10F3-01	HPS10G3-01
			HPS10C3-01	HPS10D3-01	HPS10E3-01		
			1/2 HP	3/4 HP	1HP	1-1/2 HP	2 HP
1	Motor - 115/230 Volt, 1 Phase	1	A100DHL	A100DHL	A100FLL	A100GSL	AE100G5L
1	Motor - 230/460, 3 Phase	1	AP100CH	AP100DL2	AP100EH	AP100FH	AP100GH
2	Water Slinger	1	17351-0009	17351-0009	17351-0009	17351-0009	17351-0009
3	Pump Body	1	C2-86SS	C2-86SS	C2-86SS	C2-86SS	C2-86SS
4	O-Ring	2	U9-430	U9-430	U9-430	U9-430	U9-430
5	Shaft Seal Assembly	1	U9-118	U9-118	U9-118	U9-118	U9-118
6	Pump Stack (7 GPM)	1	P325-422	P325-423	P325-424	-	-
6	Pump Stack (10 GPM)	1	P325-425	P325-426	P325-439	P325-428	P325-429
6A	Nylatron Bearing (included with Key No. 8)	1	W31112	W31112	W31112	W31112	W31112
7	Pump Shell (7GPM)	1	P56-430SSL	P56-431SSL	P56-432SSL	-	-
7	Pump Shell (10GPM)	1	P56-460SSL	P56-461SSL	P56-469SSL	P56-452SSL	P56-432SSL
8	Discharge Assembly	1	C152-4	C152-4	C152-4	C152-4	C152-4
9	Capscrew 3/8 x 16 x 1-1/4", S.S.	4	U30-75SS	U30-75SS	U30-75SS	U30-75SS	U30-75SS

### REPAIR PARTS LIST

Key No.	Description	Qty.	HP20E-02 HP20E3-02 1 HP	HP20F-02 HP20F3-02 1-1/2 HP	HP20G-02 HP20G3-02 2 HP
1	Motor - 115/230 Volt, 1 Phase	1	J218-601A	A100GSL	AE100G5L
1	Motor - 230/460 Volt, 3 Phase	1	AP100EH	AP100FHP	AP100GH
2	Handle	1	C54-21	C54-21	C54-21
3	Water Slinger	1	17351-0009	17351-0009	17351-0009
4	Pump Body	1	C2-85A	C2-85A	C2-85A
5	O-Ring	2	U9-430	U9-430	U9-430
6	Shaft Seal Assembly	1	U9-118	U9-118	U9-118
7	Pump Stack	1	P325-336	P325-337	P325-421
7A	Nylatron Bearing (included with Key No. 8)	1	W31112	W31112	W31112
8	Pump Shell	1	P56-433SSL	P56-434SSL	P56-452SSL
9	Discharge Assembly	1	C152-3A	C152-3A	C152-3A
10A	Capscrew - 3/8 x 16 x 1-1/4"	2	U30-75ZP	U30-75ZP	U30-75ZP
10B	Capscrew - 3/8 x 16 x 1-1/2"	2	U30-76ZP	U30-76ZP	U30-76ZP

### REPAIR PARTS LIST

Key No.	Description	Qty.	HPS20E-01 HPS20E3-01 1HP	HPS20F-01 HPS20F3-01 1-1/2 HP	HPS20G-01 HPS20G3-01 2 HP
1	Motor - 115/230 Volt, 1 Phase	1	J218-956C	A100GSL	AE100G5L
1	Motor - 230/460, 3 Phase	1	AP100EL2	AP100FH	AP100GH
2	Water Slinger	1	17351-0009	17351-0009	17351-0009
3	Pump Body	1	C2-86SSA	C2-86SSA	C2-86SSA
4	O-Ring	2	U9-430	U9-430	U9-430
5	Shaft Seal Assembly	1	U9-118	U9-118	U9-118
6	Pump Stack (HPS20/1 Phase)	1	P325-440	P325-431	P325-432
6	Pump Stack (HPS20/3 Phase)	1	P325-430	P325-431	P325-432
6A	Nylatron Bearing (included with Key No. 8)	1	W31112	W31112	W31112
7	Pump Shell (HPS20/1 Phase)	1	P56-470SSL	P56-434SSL	P56-452SSL
7	Pump Shell (HPS20/3 Phase)	1	P56-433SSL	P56-434SSL	P56-452SSL
8	Discharge Assembly	1	C152-4A	C152-4A	C152-4A
9	Capscrew 3/8 x 16 x 1-1/4"	2	U30-75ZP	U30-75ZP	U30-75ZP
9	Capscrew 3/8 x 16 x 1-1/2"	2	U30-76ZP	U30-76ZP	U30-76ZP

\* The 1 and 2 HP pumps use (4) U40-75SS Capscrews.



**LIMITED WARRANTY**

Sta-Rite warrants to the original consumer of the products listed below, that they will be free from defects in material and workmanship for the Warranty Period from the date of original installation or manufacture as noted.

<b>Product</b>	<b>Warranty Period</b>
Water Systems Products – jet pumps, small centrifugal pumps, submersible pumps and related accessories	<i>whichever occurs first:</i> 1 year from date of original installation, or 2 years from date of manufacture
Con-Aire® Tanks	5 years from date of original installation
Epoxy-Line Tanks	3 years from date of original installation
Sump/Sewage/Effluent Products	1 year from date of original installation, or 2 years from date of manufacture

Our warranty will not apply to any product that has been subject to negligence, misapplication, improper installation or maintenance. In the event a three phase submersible motor is operated with single phase power through a phase converter, or if three-leg ambient compensated, extra-quick trip overload relays of recommended size are not used, our warranty is void.

Buyer's only remedy and Sta-Rite's only duty is to repair or replace defective products (at Sta-Rite's choice). Buyer agrees to pay all labor and shipping charges associated with this warranty and to request warranty service through the installing dealer as soon as a problem is discovered. If warranty service is requested more than 30 days after the Warranty Period has ended, it will not be honored.

STA-RITE SHALL NOT BE LIABLE FOR ANY CONSEQUENTIAL, INCIDENTAL, OR CONTINGENT DAMAGES WHATSOEVER.

THE FOREGOING WARRANTIES ARE EXCLUSIVE AND IN LIEU OF ALL OTHER EXPRESS WARRANTIES. IMPLIED WARRANTIES, INCLUDING BUT NOT LIMITED TO THE IMPLIED WARRANTIES OF MERCHANTABILITY AND FITNESS FOR A PARTICULAR PURPOSE, SHALL NOT EXTEND BEYOND THE WARRANTY PERIOD PROVIDED HEREIN.

Certain states do not permit the exclusion or limitation of incidental or consequential damages or the placing of limitations on the duration of an implied warranty, therefore, the limitations or exclusions herein may not apply. This warranty sets forth specific legal rights and obligations, however, additional rights may exist, which may vary from state to state.

Supersedes all previous publications.

**Sta-Rite Industries, Inc. 293 Wright St., Delavan, WI 53115**

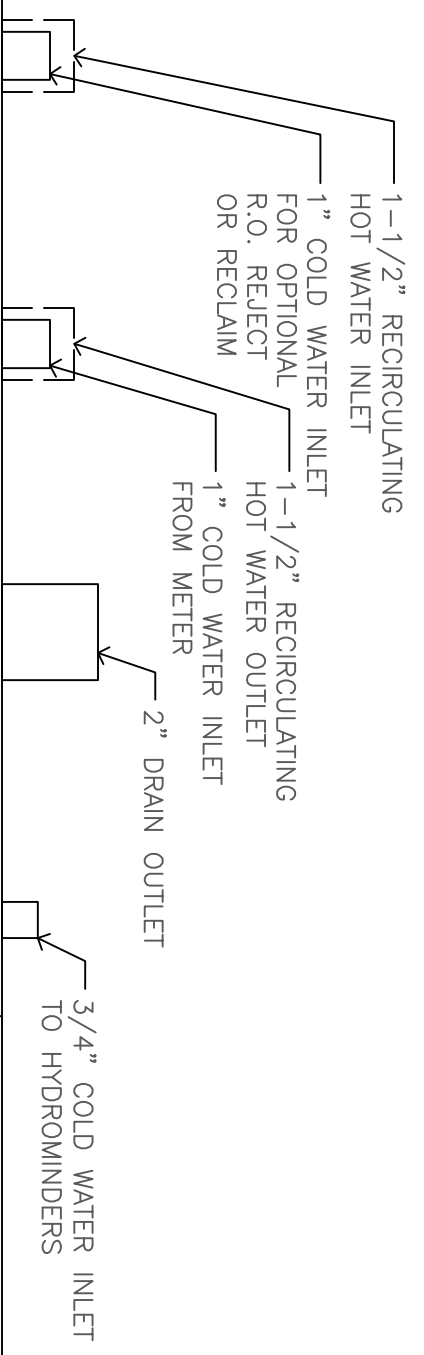

DETAIL A  
SCALE: 3" = 1'-0"

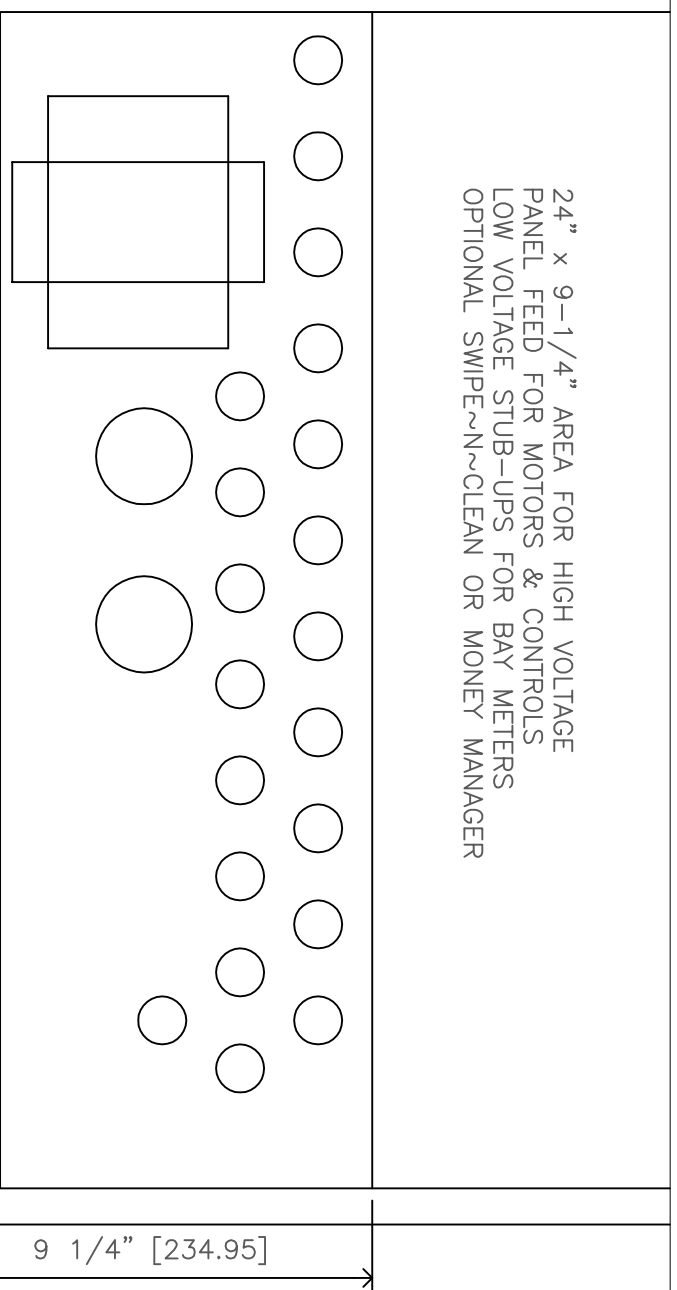

DETAIL B  
SCALE: 3" = 1'-0"

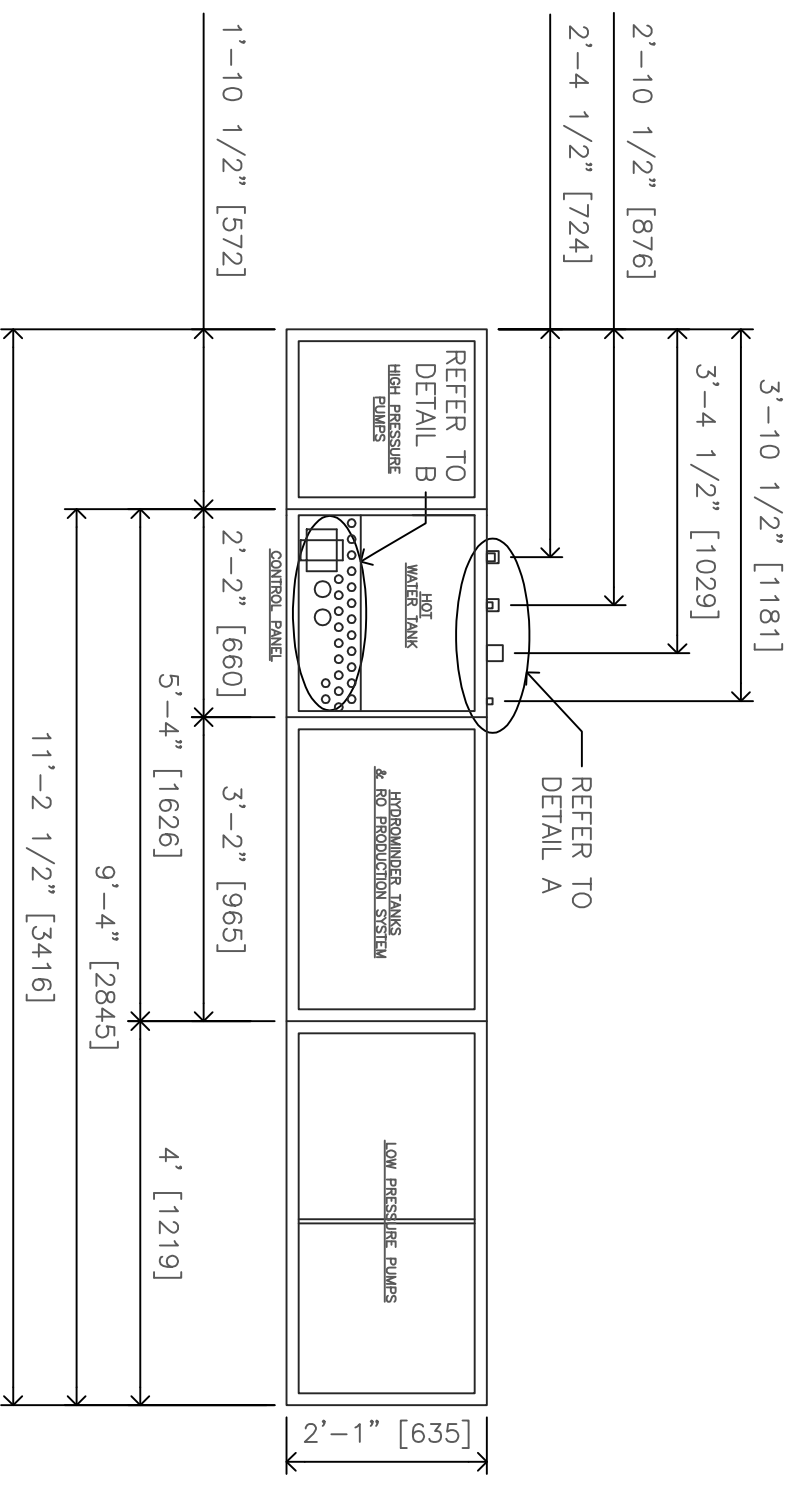

1 - 3 BAY SELF SERVE  
SCALE: 1/2" = 1'-0"

ALL DIMENSIONS BASED ON  
HIGH PRESSURE PUMPS TRIPLE  
STACKED FRAMEWORK

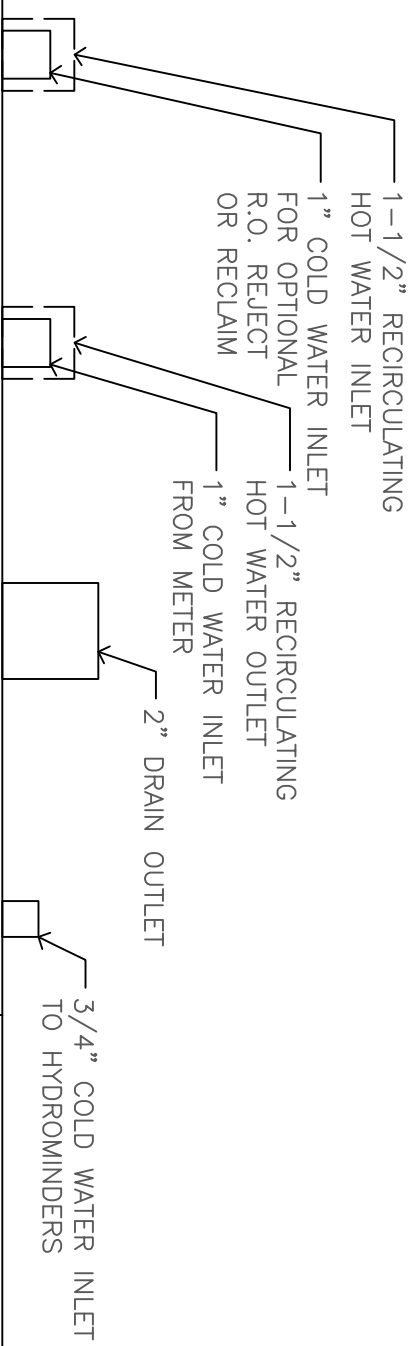

DETAIL A  
SCALE: 3" = 1'-0"

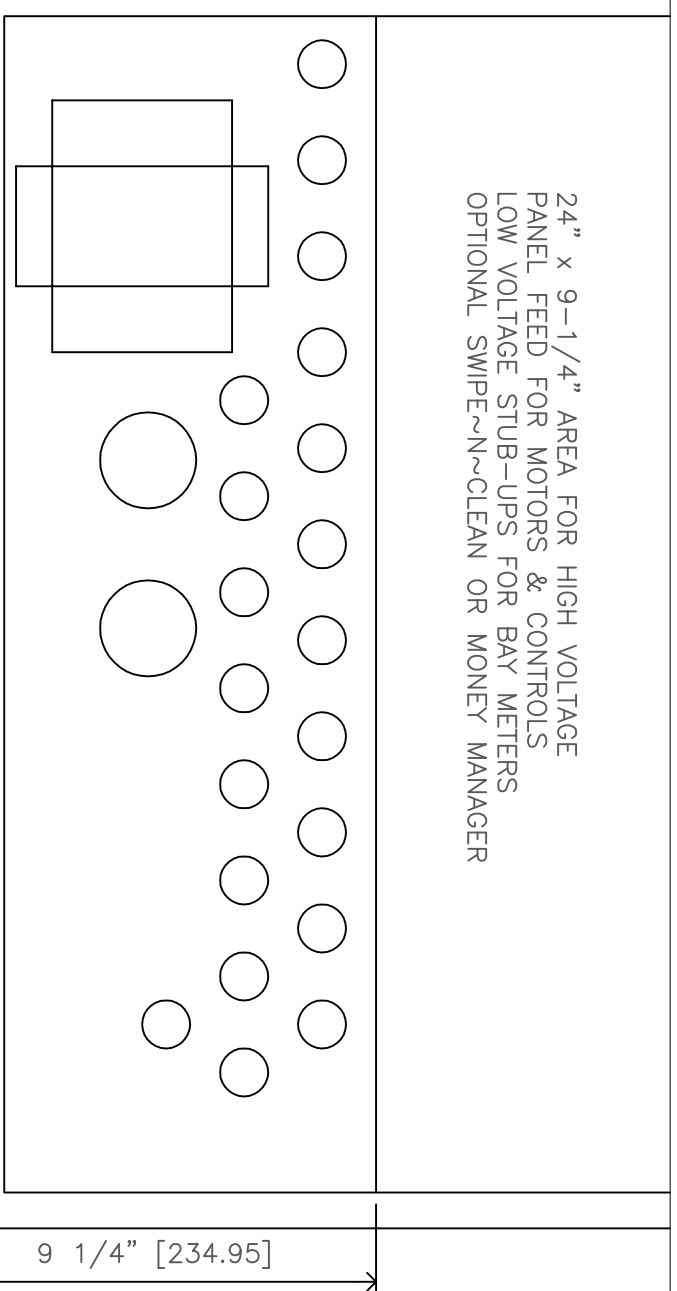

DETAIL B  
SCALE: 3" = 1'-0"

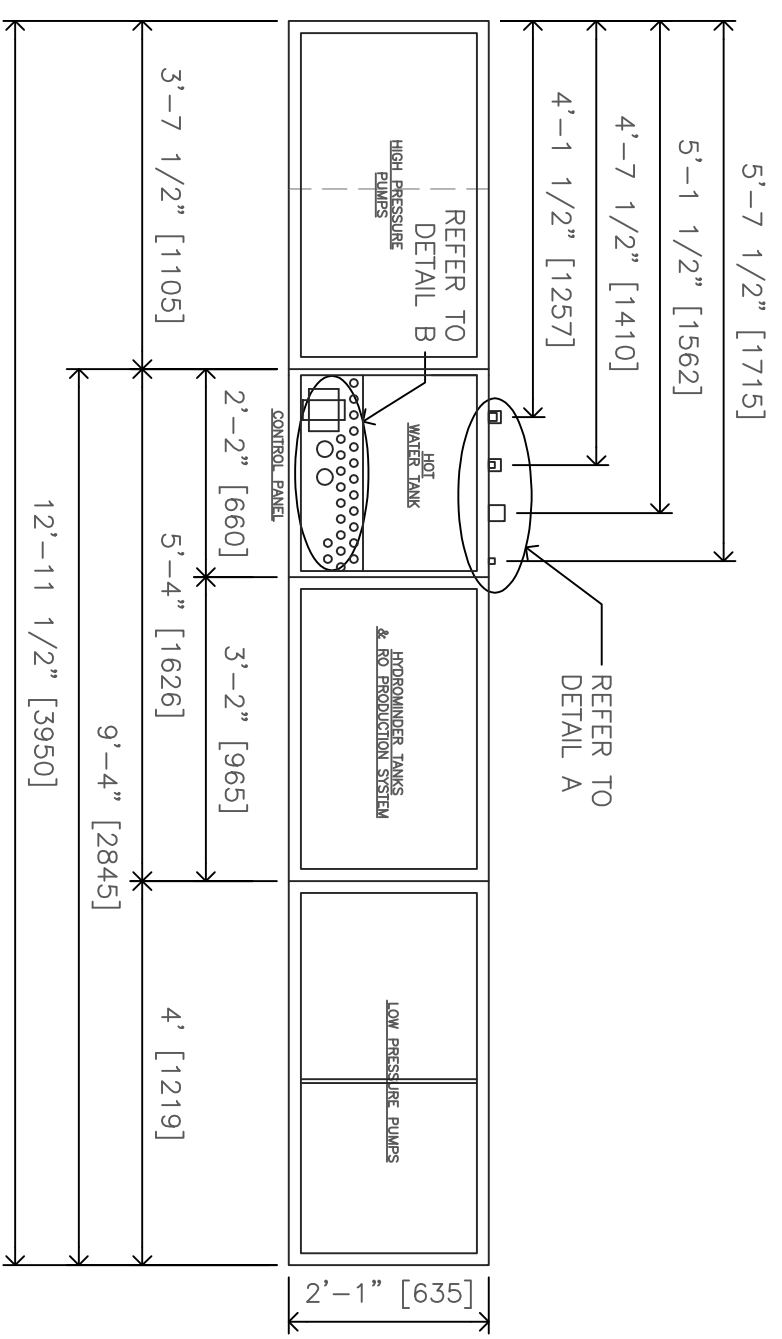

4 - 6 BAY SELF SERVE  
SCALE: 1/2" = 1'-0"

ALL DEMINIONS BASED ON  
HIGH PRESSURE PUMPS TRIPLE  
STACKED FRAMEWORK

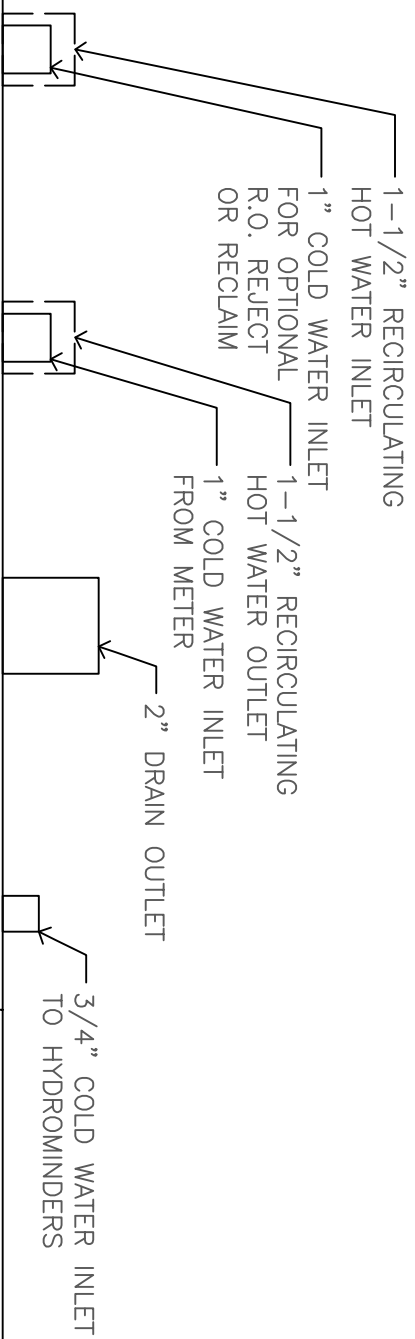

DETAIL A  
SCALE: 3" = 1'-0"

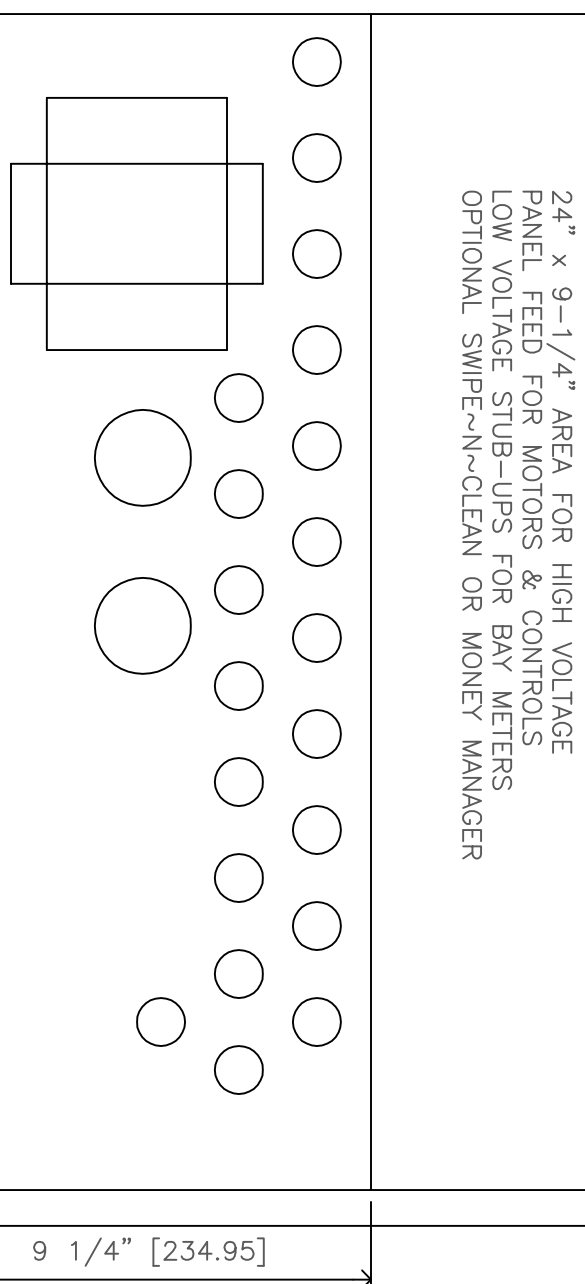

DETAIL B  
SCALE: 3" = 1'-0"

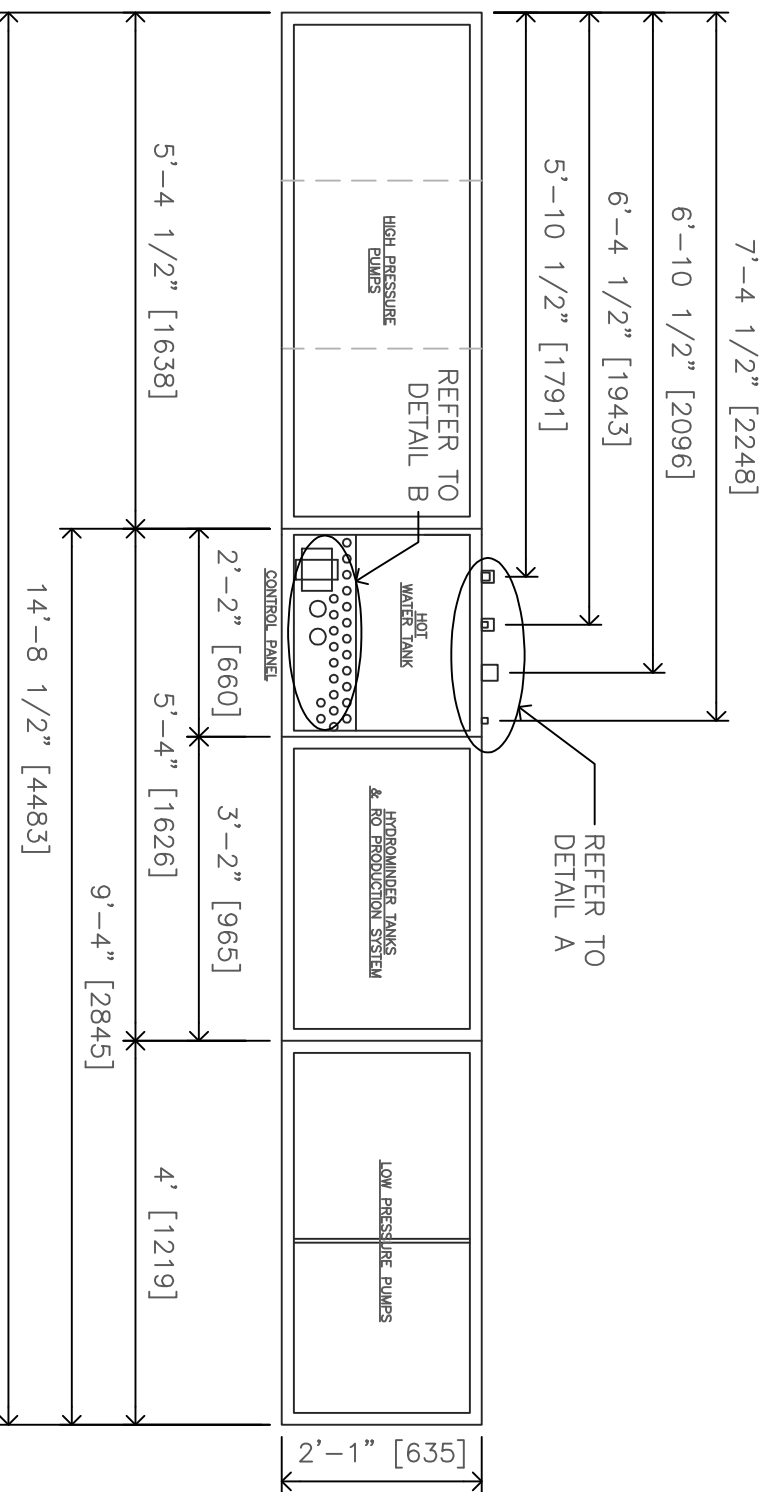

7 - 9 BAY SELF SERVE  
SCALE: 1/2" = 1'-0"

ALL DIMENSIONS BASED ON  
HIGH PRESSURE PUMPS TRIPLE  
STACKED FRAMEWORK

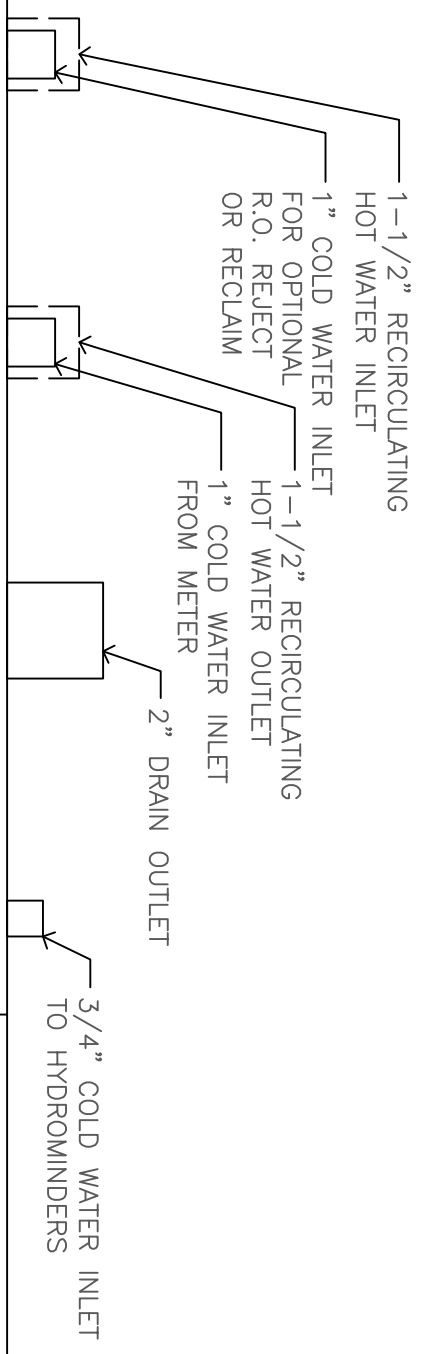

DETAIL A  
SCALE: 3" = 1'-0"

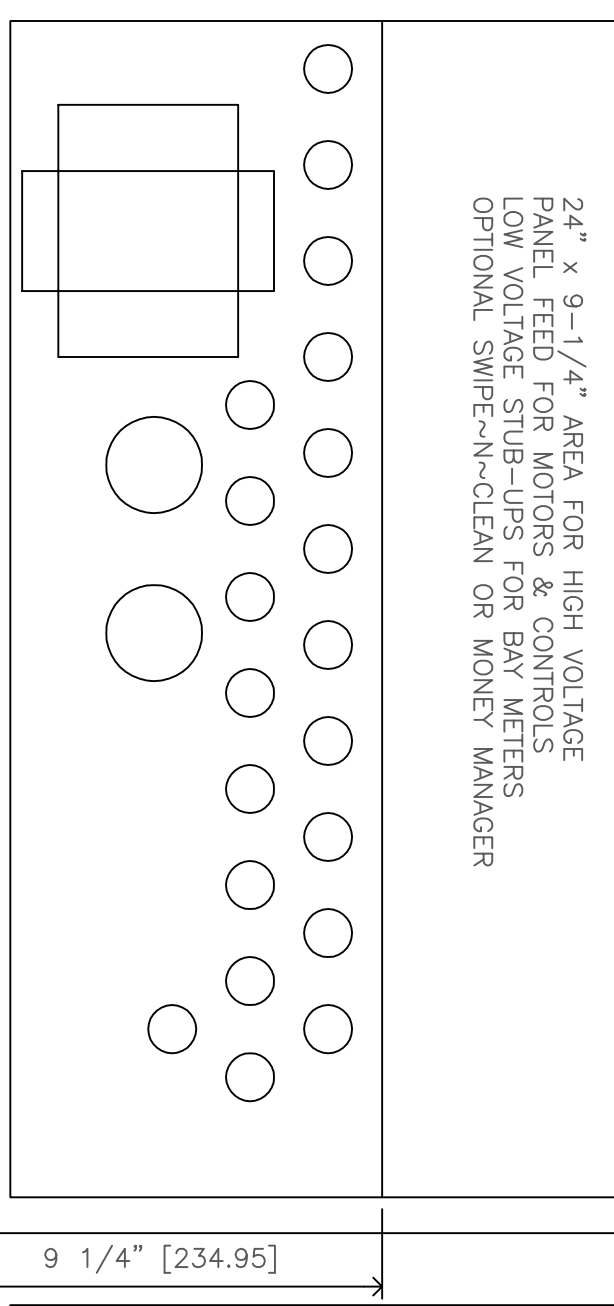

DETAIL B  
SCALE: 3" = 1'-0"

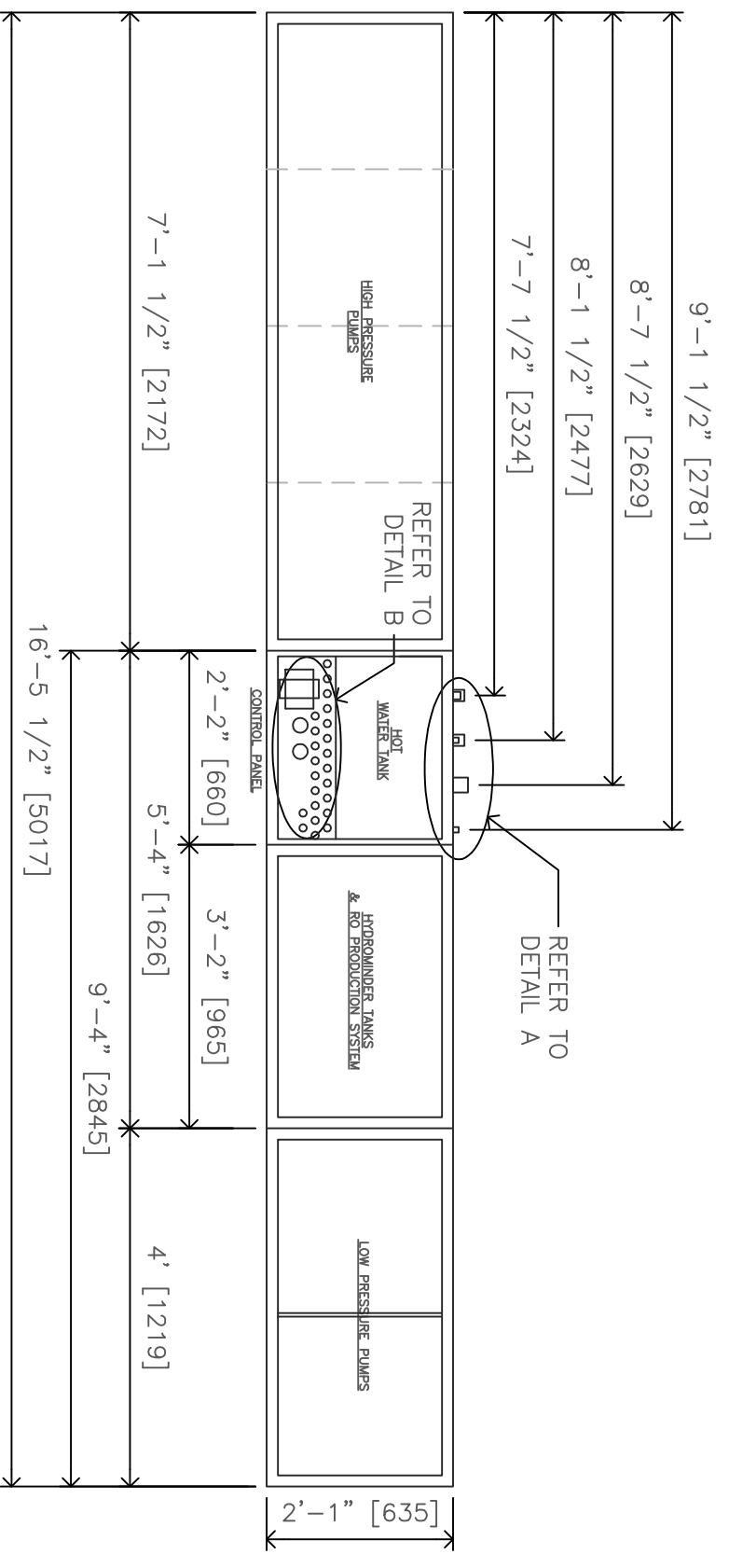

10 - 12 BAY SELF SERVE  
SCALE: 1/2" = 1'-0"

ALL DEMINIONS BASED ON  
HIGH PRESSURE PUMPS TRIPLE  
STACKED FRAMEWORK

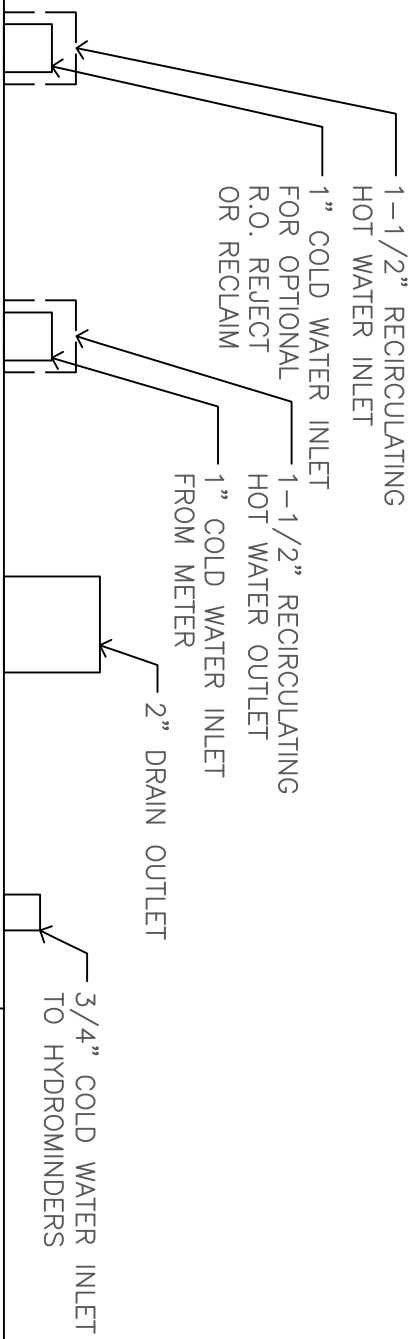

DETAIL A  
SCALE: 3" = 1'-0"

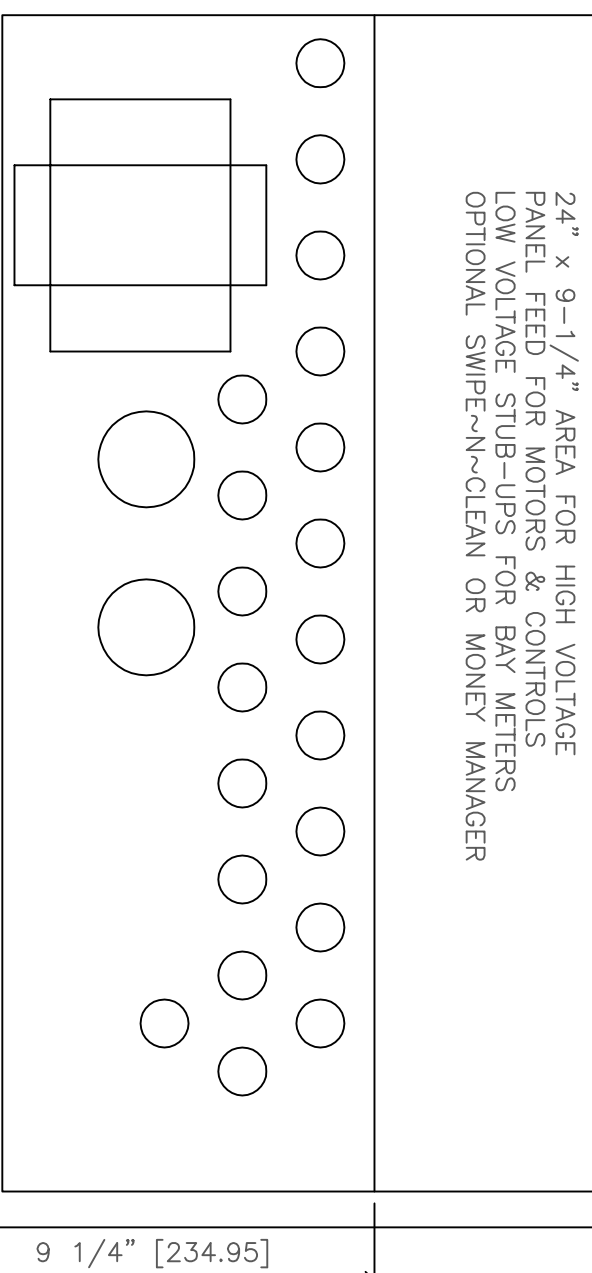

DETAIL B  
SCALE: 3" = 1'-0"

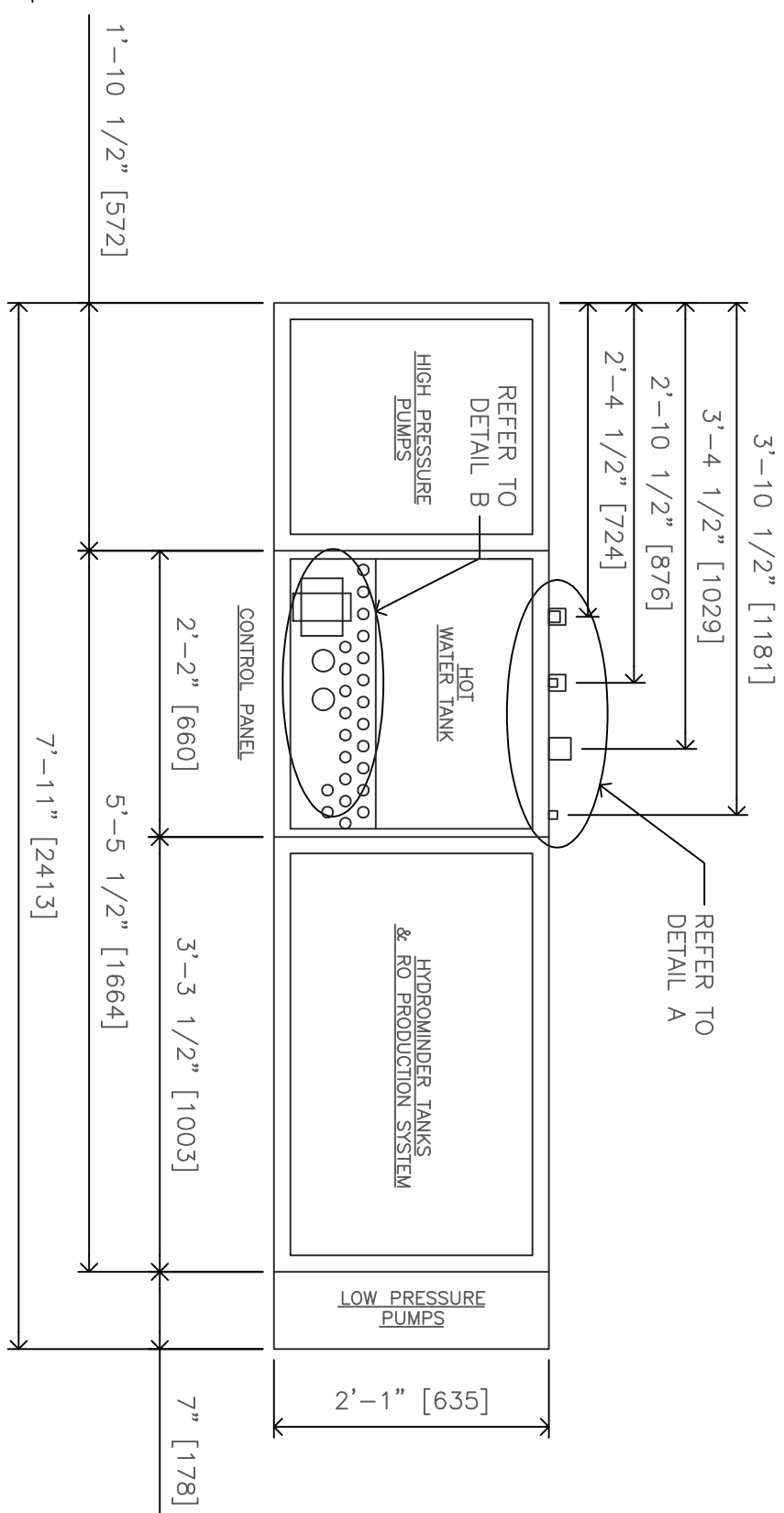

1 - 3 BAY POWER PACK  
SCALE: 3/4" = 1'-0"

ALL DIMENSIONS BASED ON HIGH PRESSURE PUMPS TRIPLE STACKED FRAMEWORK



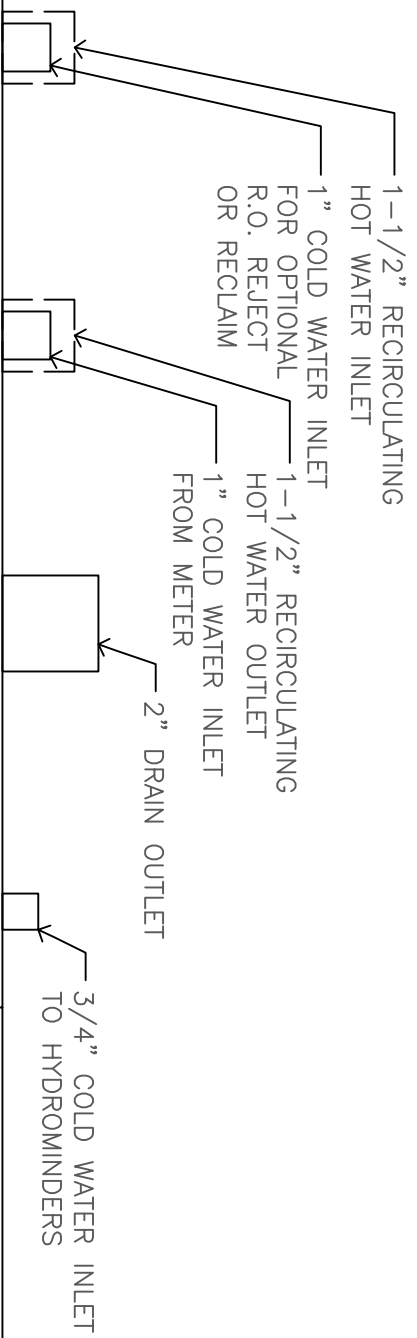

DETAIL A  
SCALE: 3" = 1'-0"

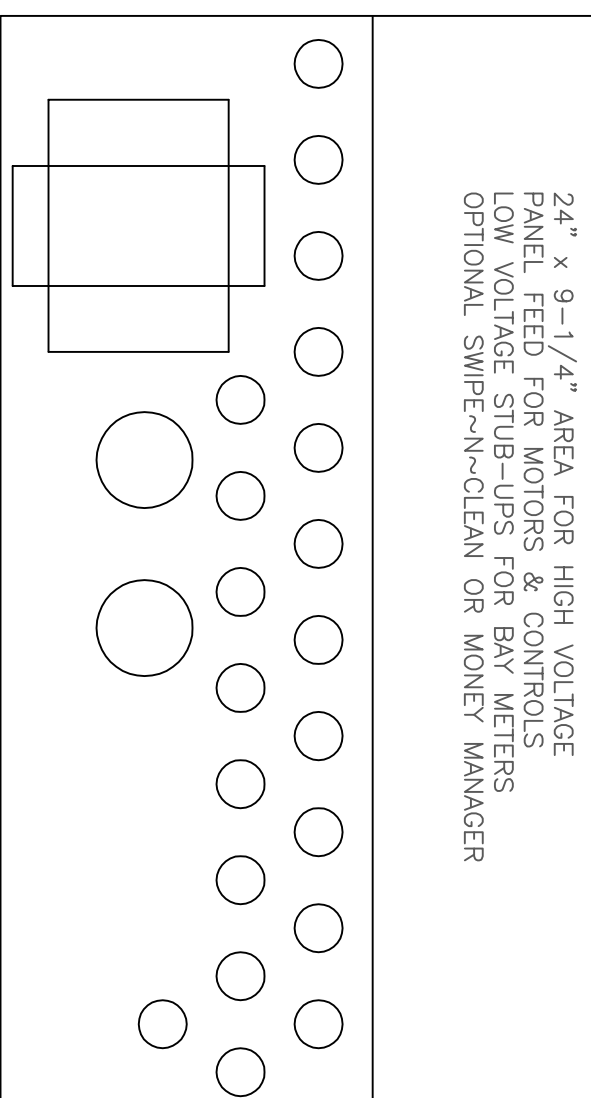

DETAIL B  
SCALE: 3" = 1'-0"

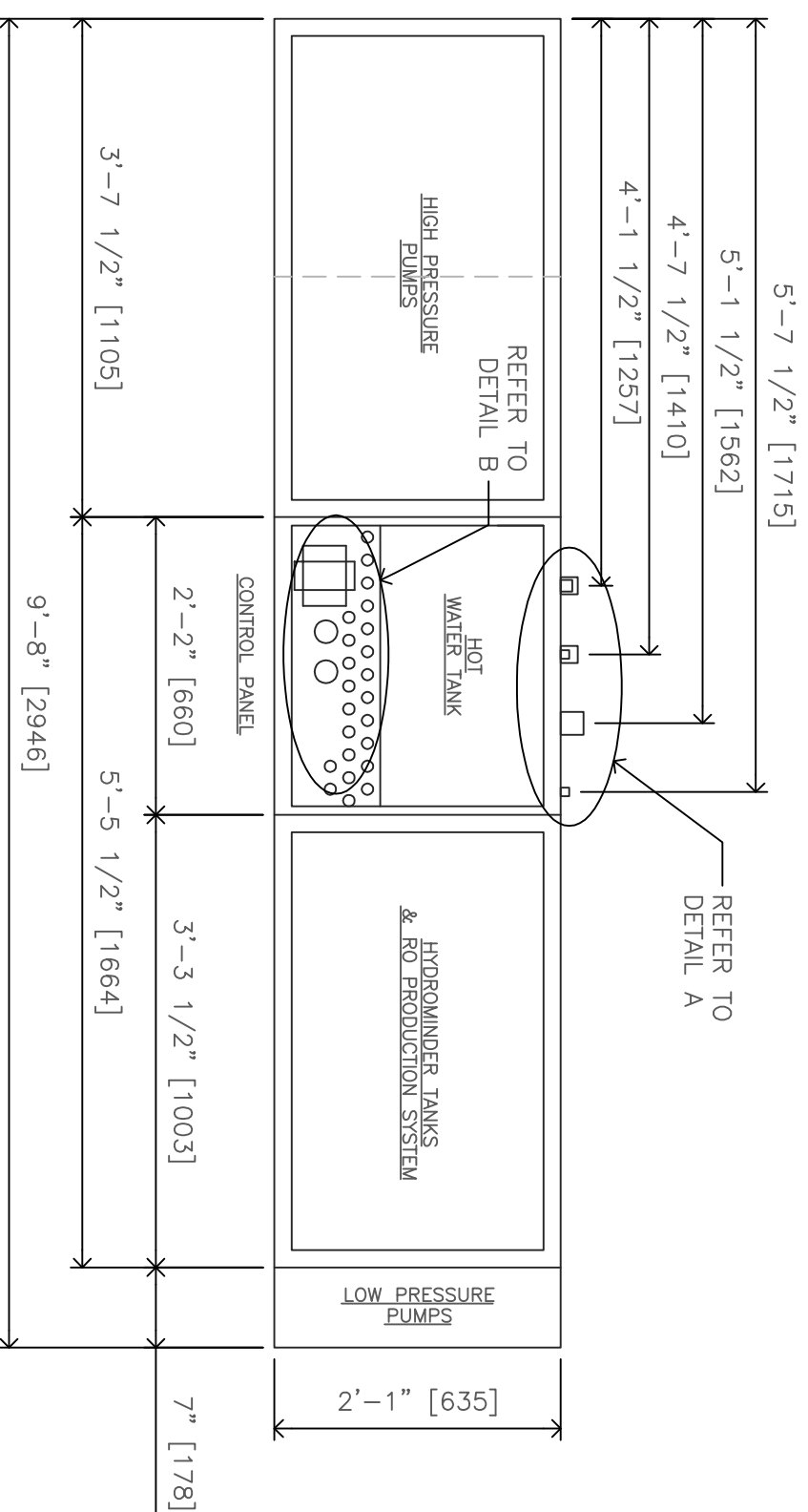

4 - 6 BAY POWER PACK  
SCALE: 3/4" = 1'-0"

ALL DIMENSIONS BASED ON HIGH PRESSURE PUMPS TRIPLE STACKED FRAMEWORK

# SINGLE R.O STAND

## OUTPUTS

- 100 SELF SERVICE DELIVERY PUMP
- 101 WATER SOLENOID
- 102 PRODUCTION PUMP
- 103 FLUSH SOLENOID
- 104 AUTOMATIC DELIVERY #1
- 105 AUTOMATIC DELIVERY #2
- 106 FLASHING LIGHT FOR LOW WATER ALARM
- 107 FLASHING LIGHT FOR LOW WATER PRESSURE ALARM

## INPUTS

- 000 PRESSURE SWITCH
- 001 LOW WATER SWITCH
- 002 HIGH WATER SWITCH
- 003 PROGRAM CHANGE
- 004 BAY 1
- 005 BAY 2
- 006 BAY 3
- 007 BAY 4
- 008 BAY 5
- 009 BAY 6
- 010 BAY 7 OR AUTOMATIC #1
- 011 BAY 8 OR AUTOMATIC #2

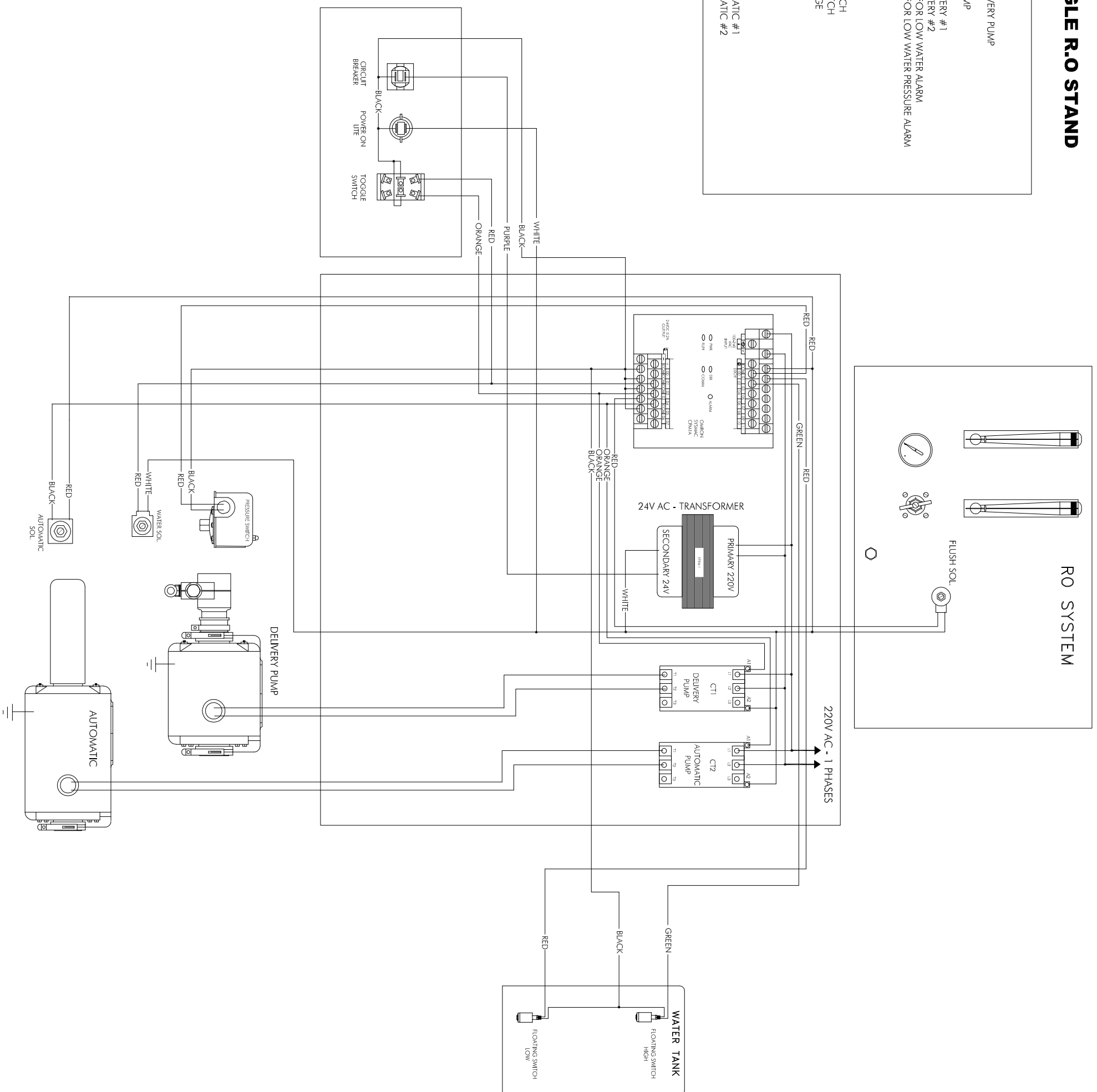

OWNER: JIM COLEMAN COMPANY 5842 W. 34TH STREET HOUSTON, TX 77092			
SHEET NAME: R.O. PANEL			
SCALE: AS SHOWN	DATE: 04/01/2002	DRAWN BY: H.PHAM	APPROVED BY: R.COLEMAN
DRAWING AKO: N/A	EQUIPMENT AKO: N/A	FILE NAME: T:\2002 SCHEMATIC\RO SYSTEM\RO1.0	

REVISIONS		

ENGINEER SEAL OR APPROVAL:	