

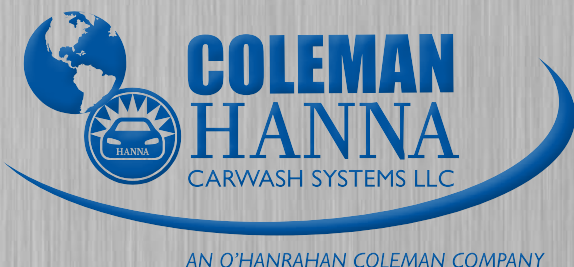

HydraBlast Wheel Washer

Service Manual



5842 W 34th St, Houston, TX 77092
1.800.999.9878 • 1.713.683.9878
www.colemanhanna.com



Find us on Facebook:
[/ColemanHannaCarwash](https://www.facebook.com/ColemanHannaCarwash)

1.0 Installation

The following information is a recommended means for installation of the Hanna High Pressure Wheel Washer. Check for the local utilities, making sure of proper access location and supply sizing. If anything must be changed, do so prior to the day of installation. Deficiencies discovered at the time of installation will greatly increase time spent before startup.



Figure 1-1. *The Hanna High Pressure Wheel Washer*

1.1 Installation Requirements

- Water: 16 GPM at 1000 PSI of water pressure
- Hydraulic: No hydraulics are required for this device
- Electrical: 1.80 Amps at 230 Volts AC to run the motor
- Pneumatic: 0.116 SCFM (Standard Cubic Feet per Minute) of air per car

1.2 Setup

This section goes over the required tools, product checks, and safety precautions needed to continue to the installation of the product.

1. Read this manual prior to opening crates or installing equipment.
2. Carefully open crates and identify the individual parts for assembly using the enclosed checklist. If there are any missing parts, notify your Hanna distributor immediately.



WARNING: IF USING A FORKLIFT TO INSTALL EQUIPMENT MAKE SURE TO FOLLOW OSHA AND GENERAL SAFETY RULES AND REGULATIONS TO ENSURE PERSONAL SAFETY.

3. Place the framework in the wash bay as shown on the layout drawing (available if purchased with system). Make sure the framework is facing the correct direction for vehicle travel. When all pieces for your configuration have been set in place, take the time to recheck the packing lists.
4. Make sure all of the necessary tools are on-hand before work is begun.
 - ✓ Set of ratchets/wrenches to secure bolts, nuts, connections, anchors, etc.
 - ✓ A mason drill to set the pilot holes for the anchor bolts.
 - ✓ Large hammer to insert the anchor bolts to the ground.
 - ✓ A power grinder to remove excess material from the anchor bolts.
 - ✓ Tube cutters for poly connections.
 - ✓ Blade/box cutter.
 - ✓ Forklifts for heavy material.
 - ✓ Tape measure to acquire proper distances and identifying marks.
 - ✓ Plumb bob to align the component to the centerline of the tunnel.
 - ✓ Teflon tape for fittings.
 - ✓ Never-seize for stainless steel hardware attachment.

1.3 Structure Installation

5. Begin installation by making sure that everything in the setup procedure is complete and have confirmed that you have everything needed to complete the installation.
6. Situate the structure so that it's perfectly over centerline of the carwash. Please refer to your M1 drawing to locate and reference where the centerline is to your system.
7. Double check for accuracy before anchoring the base plates. If centered correctly, there will be **54-55 inches** from the inner edge of the base plate on each side of the Wheel Washer to the centerline. Make sure that there is at least **30 inches of clearance** from the entrance and exit side of the Hanna Wheel Washer. This is so that the components in front of and behind the Wheel Washer are not interfered with.

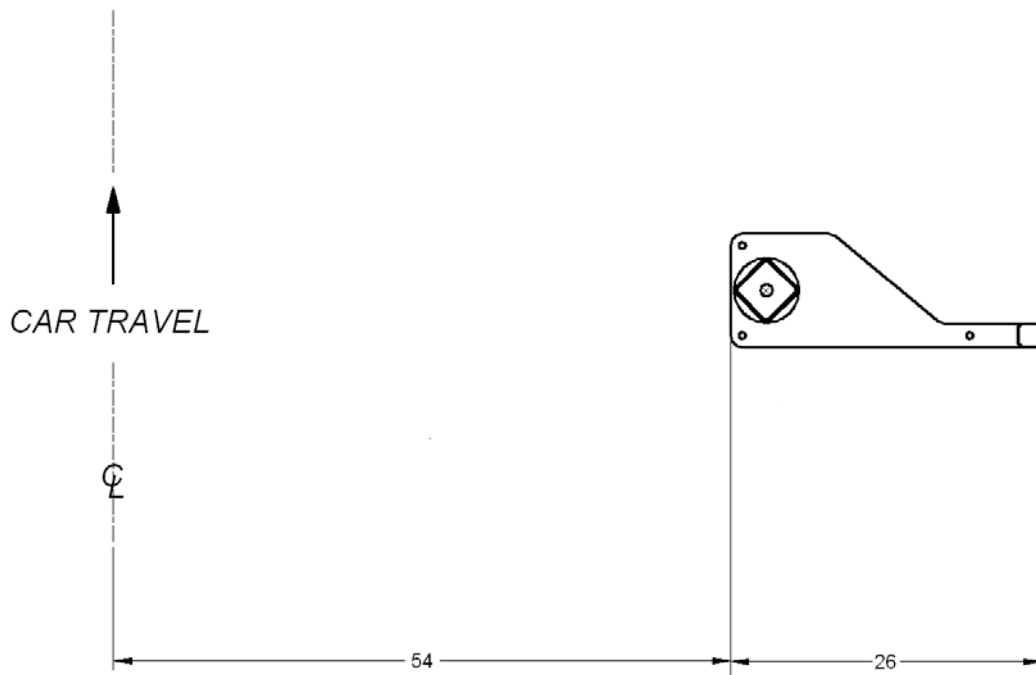

Figure 1-2 Centerline Orientation of the Hanna High Pressure Wheel Washer

- Once situated, drill the pilot holes for the anchor bolts, drive them into the ground, tighten and grind off the excess threads. Make sure there is enough clearance on each side of the component so the wash zone does not interfere with other components.

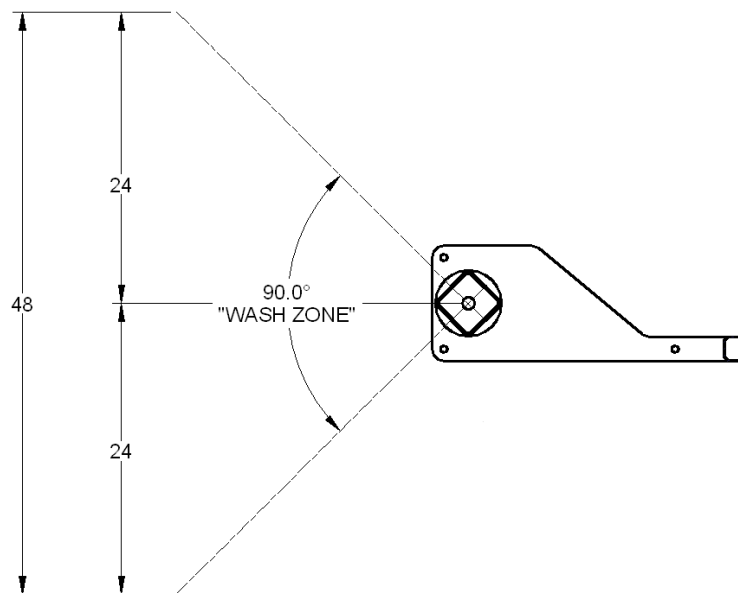

Figure 1-3. Wash Zone of the Hanna High Pressure Wheel Washer

- Double-check your nut and bolt connections on each side of the cylinder. Make sure they are loose enough so where the ends will act as hinge so the cylinder can move freely during operation.

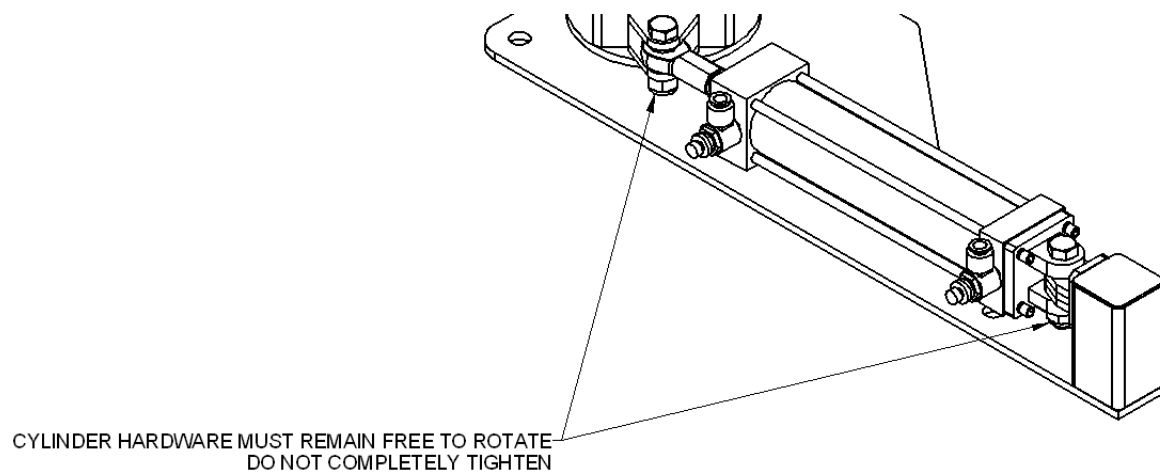

Figure 1-4. Hardware Connections on the Cylinder Assembly

10. Once properly mounted to the tunnel floor, begin making your water, pneumatic, and electrical connections to the device. **Note: For safety and organization it is recommended that the hosing and wiring be neatly bound with spiral wrap as shown in figures 1-5 and 1-6.**



Figure 1-5. *Wiring and Hosing Connections to the Wheel Washer*



Figure 1-6. *An Example of Spiral Wrap Used to Organize Hose and Wiring*

1.4 Pneumatic Connections

This section covers the needed air connections to make sure that all retract controls are properly installed

11. Two retract cylinder assemblies on the Wheel Washer require a total of four 3/8" poly air hose connections. There will be two tee-fitting connections that will lead to the pneumatic board (one tee fitting for the turn left motion and one tee fitting for the turn right motion).

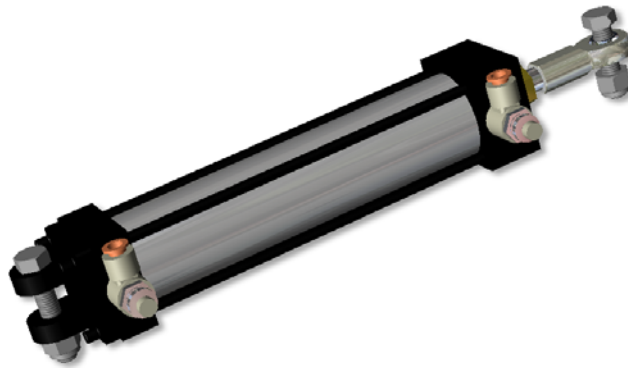

Figure 1-7. *Pneumatic Cylinder Assembly*

12. Figure 1-9 portrays the pneumatic board for controlling the extended and retract command to the air cylinders. The air required to run the Wheel Washer retracts is **.116 SCFM per car**.
13. During runtime, use the pneumatic flow adjuster on the cylinder to create a smoother pan movement to match the conveyor speed. Turning the airflow adjustment knob shown in figure 1-8 does this. Use the stop adjustment ring to limit how much the airflow can be adjusted.



Figure 1-8. *Pneumatic Flow Adjustment*

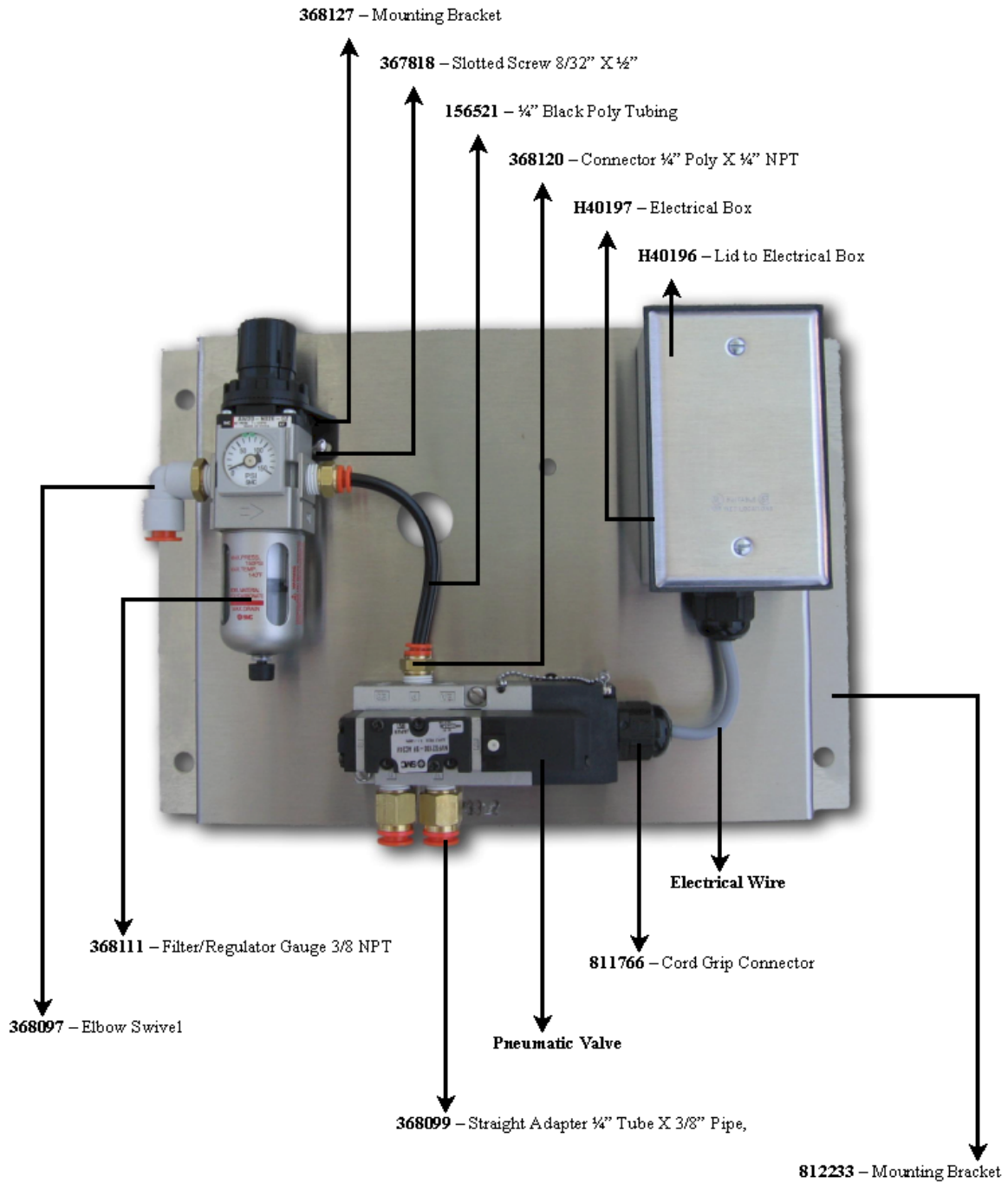

Figure 1-9. Pneumatic Valve Board for Arm Retract and Extend Motion

1.5 Water Connections

This section covers the needed connections to make sure that water is available to the correct areas.

14. In order for the High Pressure Wheel Washer to run effectively, the use of a single level high pressure pumping station is required. The flow rate must be **16 GPM** with a water pressure **1000 PSI**.
15. Branch off the hose leading from the Pump Station to the Wheel Washer with a T-fitting. Connect a hose to each of the 3/8" connections located in the back of each of the motors. Figure 1-8 portrays the swivel connector and adapter used.

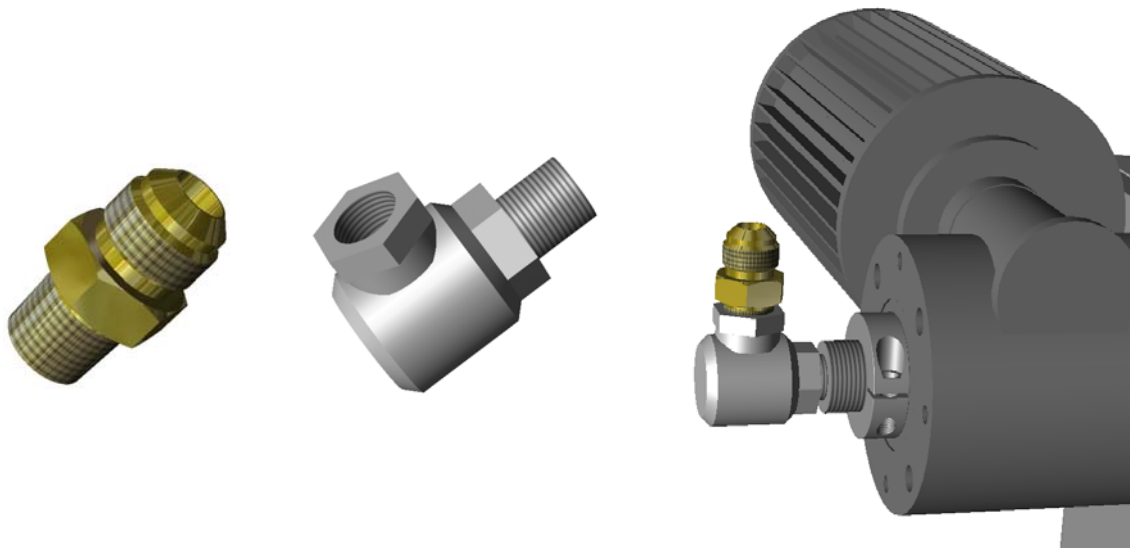

Figure 1-10. Water Connection Fittings Used For the High Pressure Wheel Washer

1.6 Electrical Connections

This section covers the electrical requirements needed to run the motor.

16. **1.80 AMPS at 230 Volts AC** is the required electrical energy to run the motor.

The motor utilizes a **three-phase connection**.

17. There will be 4 wires that will have to be connected from the Motor.

- Green Wire – Ground
- White Wire – Line 1
- Black Wire – Line 2
- Red Wire – Line 3



Figure 1-11. AC Right Angle Gear Motor

1.7 Setting Up With Wheel Tracking Controllers

Some Tunnel Wash Controllers are not capable of identifying or tracking individual wheels of vehicles. For these Wash Controllers, the wheel sensor will be operated in a “On-Demand” mode. This sensor will identify when a wheel is present and fire the pivot cylinder relay directly, bypassing the tunnel controller. The sensor has adjustable delays, so the signal can be manipulated to ignore erroneous data, such as water drops, and provide a continuous pivoting action even after the wheel has cleared the sensor.

1.8 Setting Up With Non-Wheel Tracking Controllers

For those tunnel controllers capable of identifying and tracking individual wheels, the sensor will be connected to the tunnel controller. This sensor will act as a standard ordinary sensor. The tunnel controller processor will determine the timing on the output functions. This sensor may still require some manipulation to ignore erroneous data, such as water drops.

1.9 Startup

This sections covers the description of how the Height Pressure Wheel Washer operates after a successful install and what should be done before washing cars.

18. Before running, it is very important that the water piping is flooded without the brass jets connected. Using the pump saturation, force through a liberal amount of water at normal running pressure. This is important to prevent any possibility of jet clogging. Flushing out the system will free the pipes of any loose debris that may have been lodged during the manufacturing process or through transit. Once flooded has been complete replace the brass jets.
19. When in operation mode, as the vehicle enters the car wash, the wheels are scanned and loaded into the tunnel controller memory. If your tunnels controller does not track wheel position, please refer to the non-wheel tracking controllers section of the manual
20. As the vehicle approaches the wheel washer, the contactor for the high-pressure pump and the rotational electric motor are closed simultaneously.

21. The Wheel Washer will then build to maximum operating pressure. This should be done 5 seconds before the wheels reach the edge of the wash zone.
22. Once the wheel is fully engulfed in the rotating spray, a signal is sent to the pneumatic panel, opening the pneumatic valve, and forcing both cylinders to extend. This will cause the pivot post to rotate.
23. The rotational speed of the pivot post is controlled by the flow control valves mounted directly on the air cylinders. Please refer to the pneumatic section of them manual on how adjust these flow control valves.
24. The wheel washer will continue to follow the wheel until it reaches maximum pivot rotation or until the next wheel comes into range of the wash zone.
25. Just prior to this time, the signal to the pneumatic valve is cancelled, the pneumatic valve closes, and the pivot post returns to its original position.
26. If the next wheel is the second wheel of the same car, the cycle repeats with the exception that the contactors for the pump and rotational motor will remain on prior to the wheel's approach.
27. The pneumatic valve must be re-energized for each wheel.



Figure 1-12. Wheel Washer in Action (guard removed for visual purposes)

2.0 Safety

Keep the following safety rules in mind when installing and using Hanna Car Wash Systems

Equipment:

NOTE: *Always follow local and national trade codes when installing any equipment.*

- Always disconnect power from any electrical device or component prior to servicing.
- Unplug the unit or use proper lock-out procedures so that no one can inadvertently turn the power on while you are working on that equipment.
- Use caution when maintaining any piece of equipment.
- Wear protective clothing and eyewear when using power tools.
- Direct discharge of high-pressure water and chemicals away from you and other persons, or direct it into approved containers.
- Keep equipment clean for proper operation.
- Keep hands or any body parts away from equipment while in operation.
- If you need to disassemble a part for service or repair, re-assemble equipment according to instructions.
- Be sure all components are firmly screwed or latched into position.
- Observe safety and handling instructions of the chemical manufacturers.
- Wear protective clothing and eyewear when dispensing or working with chemicals or other potentially hazardous materials.

2.1 Cautions, Warnings, and Notes

Throughout this manual there are various messages concerning safety – please heed these warnings!

2.1.1 Cautions

Cautions warn against a potential hazard that, if not avoided, may result in minor or moderate injury. Caution signs also alert against unsafe practices that may cause property damage.



CAUTION:

2.1.2 Warnings

Warning messages warn against a potential hazard that, if not avoided, may result in serious injury or death.



WARNING:

2.1.3 Notes

Note means reader take note. Notes contain helpful suggestions.

NOTE: *This parameter should NOT be changed when attempting to make system adjustments.*



Jim Coleman Company/Hanna Car Wash Systems

Main Office

5842 West 34th Street
Houston, TX 77092

800-999-9878 • 713-683-9878 • Fax: 713-683-9624
www.jcolemanco.com

Hanna Division Office

7905 Blankenship Dr.
Houston, TX 77055

866-683-6615 • 713-683-6615 • Fax: 713-590-6630
www.hannacarwash.com



Jim Coleman Company/Hanna Car Wash Systems

Main Office

5842 West 34th Street
Houston, TX 77092

800-999-9878 • 713-683-9878 • Fax: 713-683-9624
www.jcolemanco.com

Hanna Division Office

7905 Blankenship Dr.
Houston, TX 77055

866-683-6615 • 713-683-6615 • Fax: 713-590-6630
www.hannacarwash.com