

# Hub Cap Rocker Panel Brush

## *Service Manual*

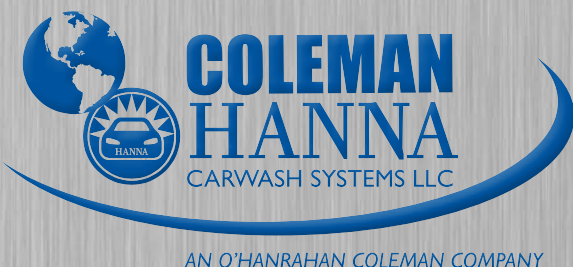

5842 W 34th St, Houston, TX 77092  
1.800.999.9878 • 1.713.683.9878  
[www.colemanhanna.com](http://www.colemanhanna.com)



Find us on Facebook:  
[/ColemanHannaCarwash](https://www.facebook.com/ColemanHannaCarwash)

# Table of Contents

**1.0 INTRODUCTION..... 1-1**

1.1 Design Features..... 1-2

    1.1.1 Frame ..... 1-2

    1.1.2 Legs and Frame Supports..... 1-2

    1.1.3 Brushes..... 1-3

    1.1.4 Cloth Panels ..... 1-3

    1.1.5 Arm Assemblies..... 1-3

    1.1.6 Arm Leveling..... 1-4

    1.1.7 Core Weldments..... 1-4

    1.1.8 Shock and Spring Assemblies..... 1-4

    1.1.9 Hydraulic Motors ..... 1-5

    1.1.10 Hydraulic Plumbing ..... 1-5

1.2 Basic Operation..... 1-5

    1.2.1 Side of Vehicle..... 1-6

    1.2.2 Electrical Controls ..... 1-6

    1.2.3 Water Plumbing ..... 1-6

1.3 Optional Equipment ..... 1-6

    1.3.1 Cloth Material ..... 1-7

    1.3.2 Brush Retract Controls..... 1-7

**2.0 SAFETY ..... 2-1**

2.1 Cautions, Warnings, and Notes..... 2-2

    2.1.1 Cautions ..... 2-2

    2.1.2 Warnings..... 2-2

    2.1.3 Notes ..... 2-2

<b>3.0</b>	<b>INSTALLATION</b> .....	<b>3-1</b>
3.1	Installation Requirements .....	3-1
3.2	General Requirements.....	3-1
3.3	Installation.....	3-1
3.4	RPM Adjustment .....	3-3
3.5	Hydraulic Fitting Assembly and Remake (A-LOK™) for Pressure Compensated Hydraulic Power Units .....	3-4
3.6	Hydraulic Fitting Torque (Triple-LOK™) for Fixed Displacement Hydraulic Power Units.....	3-6
3.7	Hanna Hydraulic Tubing Color Code.....	3-7
<b>4.0</b>	<b>PARTS AND MAINTENANCE</b> .....	<b>4-1</b>
4.1	General Maintenance .....	4-1
4.1.1	Daily Maintenance .....	4-1
4.1.2	Weekly Maintenance .....	4-1
4.1.3	Monthly Maintenance .....	4-2
4.2	Lubrication.....	4-2
4.3	Spare Parts List .....	4-3
4.4	Recommended Tool Kit.....	4-4
<b>5.0</b>	<b>TROUBLESHOOTING</b> .....	<b>5-1</b>
5.1	Brush Problems.....	5-1
5.2	Hydraulic Fitting Problems.....	5-2

## **Table of Figures**

Figure 1-1 Hanna XT Hub-Cap Rocker Panel Brush ..... 1-1

Figure 1-2 Hanna XT HCRP Brush Assembly ..... 1-3

Figure 1-3 Hanna XT HCRP Arm Assembly ..... 1-3

Figure 1-4 Hanna XT HCRP Core Weldment ..... 1-4

Figure 1-5 Hanna XT HCRP Shock and Spring Assembly ..... 1-4

Figure 1-6 Hanna XT HCRP Hydraulic Motor..... 1-5

Figure 1-7 Hanna XT Retract Cylinder Assembly ..... 1-7

Figure 3-1 A-LOK Fitting Remake..... 3-5

Figure 3-2 Hanna Hydraulic Tubing Color Code ..... 3-7

Table 3-1 Triple-LOC Assembly Torques and FFWR ..... 3-6

Table 4-1 Recommended Spare Parts List..... 4-3

Table 4-2 Recommended Installation Tools ..... 4-4

This page intentionally left blank.

## 1.0 Introduction

The Hanna XT Hub-Cap Rocker Panel (XT HCRP) Brush (Figure 1-1) represents the next generation of Hanna developed and Hanna tested modular car wash systems. This side-supported stainless-steel brush offers superior cleaning while gently washing all types and shapes of vehicles. Double rotating brushes concentrate cleaning motion to the lower vertical surfaces of the vehicle.

The XT series of brushes is part of the new Hanna XT modular structure and offers the car wash owner a new option to provide top service and reliability to their customers at an affordable cost. The XT HCRP Brush is also available in freestanding options.

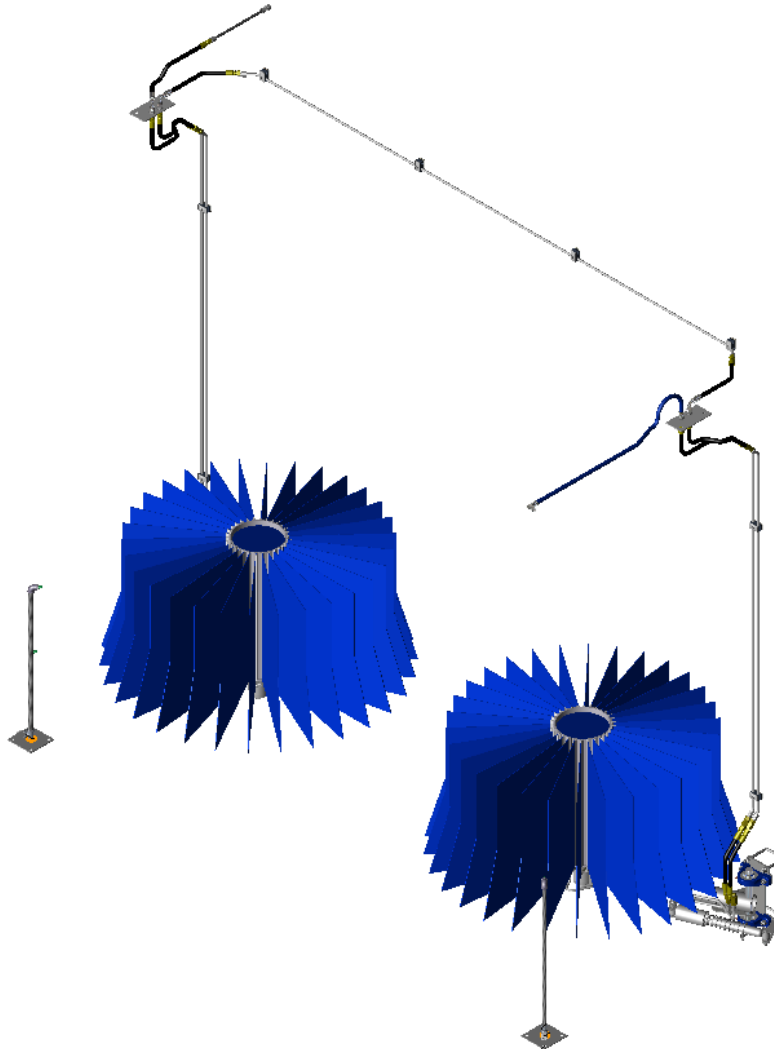

Figure 1-1 *Hanna XT Hub-Cap Rocker Panel Brush*

## 1.1 Design Features

The combination of the brush rotation, the vehicle's forward movement, and the basic design make the XT HCRP Brush a fully self-controlled unit. Two side brushes make up the XT HCRP, one on the right side and one on the left side. The brush design, with properly adjusted side pressure, provides a clean wash, regardless of vehicle size or shape. It is available in hydraulic drive only.

The brushes exhibit horizontal side movement (in and out) while the two rotating brushes turn into the vehicle. The rotating brushes provide superior cleaning on the sides of the vehicle.

The brushes are constructed of a long-life synthetic material designed to combine maximum cleaning ability with complete safety for any finish. They are completely safe for all types of synthetic lacquer surfaces or clear coat finishes.

The XT HCRP Brush is available in several height (spinning action) options, 21 in. (53.3 cm), 28 in. (71.1 cm), and 35 in. (88.9 cm). The brush utilizes a direct-drive hydraulic motor. This drive offers the flexibility of variable-speed adjustments. With variable speed (by adjusting the hydraulic valve), multi-textured wash material, and spinning action the XT HCRP is the most effective rocker-panel cleaning brush in the car-wash industry.

### 1.1.1 Frame

The XT HCRP Brush will adapt to any XT frame where clearance allows. Consult with your local distributor for specifics. Post weldments are available with freestanding options.

### 1.1.2 Legs and Frame Supports

The XT HCRP Brush will adapt to any XT frame where clearance allows. Consult with your local distributor for specifics.

### 1.1.3 Brushes

The brush is contoured to provide improved cleaning of the lower vertical surface of the vehicle (rocker panel). The brush material is heavy pack. Brush speed recommended at 75 RPM (for cloth).

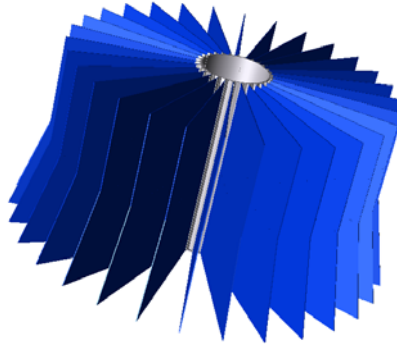

Figure 1-2 *XT HCRP Brush Assembly*

### 1.1.4 Cloth Panels

The cloth panels that make up the brushes are manufactured of a mixture of polypropylene and polyethylene fibers needed together to make cloth. Each brush mounting is engineered for maximum longevity ease of installation, and serviceability.

### 1.1.5 Arm Assemblies

All arms *must be level* in order for the brushes to function normally. The arms are made of high-quality stainless steel with the strength and rigidity needed for years of trouble-free service.

Each arm is 32 in. long and supported by two pillow-block bearings mounted to the exit side of the support post. The bearings need periodic lubrication with high-quality lithium grease. The shock and spring stabilizer assembly is attached to a post bracket and the brush-arm assembly. The function of the stabilizer is to control the brush to vehicle pressure and to return the brush-arm assembly to a rest position after the vehicle has passed.

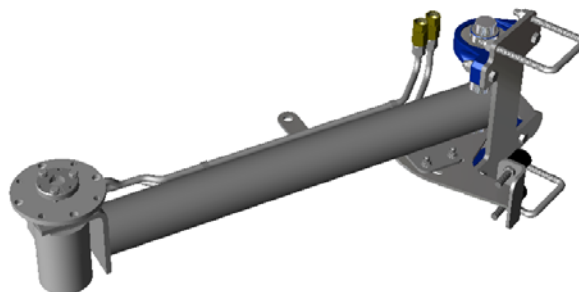

Figure 1-3 *XT HCRP Arm Assembly*



### 1.1.6 Arm Leveling

Smooth arm motion is a requirement for a well-tuned brush unit. To achieve arm leveling adjust the U-bolts on the arm bracket during installation or service with the use of a hand level.

### 1.1.7 Core Weldments

There is one aluminum-core shaft assembly above each arm. The assemblies hold the cloth panels that clean the vehicle.



**Figure 1-4** *XT HCRP Core Weldment*

### 1.1.8 Shock and Spring Assemblies

One shock and spring assembly is located under each arm. The assemblies are required in order for the arms to have enough reach to completely wash the sides of any vehicle. The shock and spring assemblies keep the arms in the rest position in addition to keeping pressure on the brush when it is rotating on the side of a vehicle. An optional “retract” is available.

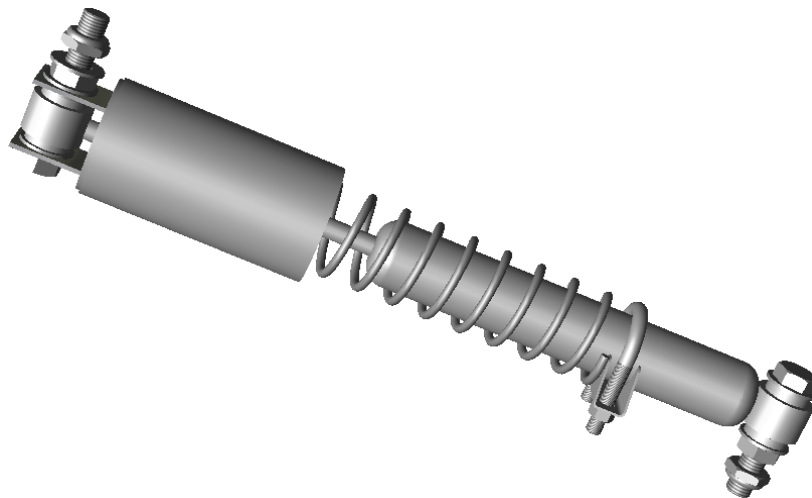

**Figure 1-5** *XT HCRP Shock and Spring Assembly*

### 1.1.9 Hydraulic Motors

There is one hydraulic motor mounted on each arm. These motors are direct drive and interchangeable between each arm assembly.



Figure 1-6 *XT HCRP Hydraulic Motor*

### 1.1.10 Hydraulic Plumbing

The hydraulic stainless steel lines are identified by a single band of colored tape and a double band of colored tape. The single band of colored tape denotes the pressure line and the double band of tape the return line.

## 1.2 Basic Operation

The XT HCRP Brush is designed to activate as a vehicle approaches and shut off as the vehicle moves past the brush. This is accomplished with a hydraulic solenoid valve on the hydraulic power unit if provided. Water to wet down the brushes is activated by a solenoid valve with internal plumbing only.

The system features two sets of rotating brushes with each featuring 30 cloth cleaning panels to give superior cleaning of the vertical surfaces of a vehicle. The rotating motion gently cleans the vehicle as the soft cloth conforms to the vehicle's shape.

The brush follows the contour of the vehicle through the action of the supporting arms. Brush rotation pressure against the vehicle surface, forward movement of the vehicle, and a shock and spring assembly supply the necessary pressure to extend the arm.

The brush employs a simple, yet effective, water dispensing system. Dispensing jets are located on the exit side of the brush to ensure maximum coverage of the brush area as well as a flushing action on the wash material to keep it clean.

The brush utilizes a direct-drive hydraulic motor on each arm. This drive motor offers the flexibility of variable-speed adjustments (by adjusting the central valve on the hydraulic unit). This combination of a variable speed motor, multi-textured wash material, and flexible arms produce the most effective cleaning brush in the industry.

The XT HCRP brush motors rotate continuously as long as the solenoid valve on the hydraulic power unit is operating. The brush arm assemblies are mounted to the exit side of the support post. The brush assemblies swing independently from one another in the direction of vehicle travel. Pressure of brush-to-vehicle contact is achieved by a shock with spring assembly, allowing brushes to conform to the contours and widths of individual vehicles' vertical surfaces.

### 1.2.1 Side of Vehicle

Due to the relative smooth surfaces found on the sides of vehicles, it would seem that the sides of a vehicle are the easiest to wash. In contrast, the sides of a vehicle are usually the most difficult to clean due to the highly visible large surfaces, as well as the presence of tough road grime located directly behind the wheels and tires. Hanna's XT HCRP Brush can effectively wash the sides of a vehicle because its brushes are capable of maintaining *gentle* and *consistent* brush contact throughout the entire length of the vehicle.

### 1.2.2 Electrical Controls

Hanna's XT HCRP Brush actually has very little in electrical controls. For most applications, the only electrical controls are the hydraulic solenoid and water application solenoid, operated by the system controller.

### 1.2.3 Water Plumbing

The XT HCRP Brush is supplied with a water spray manifold for each brush. If the Brush has foam brushes, high lubricity soap is *required*.

## 1.3 Optional Equipment

Hanna offers a variety of optional equipment. Check with your local distributor for additions to your equipment.

### 1.3.1 Cloth Material

Both cloth and foam (closed cell) wash materials are available in a wide variety of colors. Please contact your local Hanna distributor for information.

### 1.3.2 Brush Retract Controls

The XT HCRP Brush control system is capable of a “Retract” option. Please contact your local Hanna distributor for information.

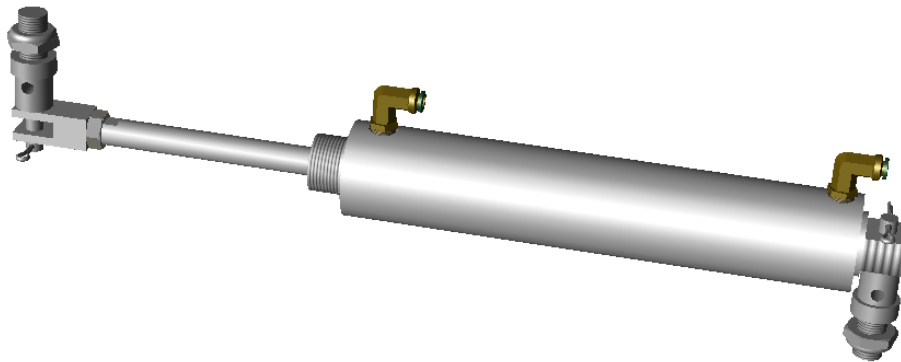

**Figure 1-7** *XT HCRP Retract Cylinder Assembly*

This page intentionally left blank.

## 2.0 Safety

Keep the following safety rules in mind when installing and using Hanna Car Wash System Equipment:

**NOTE:** *Always follow local and national trade codes when installing any equipment.*

- Always disconnect power from any electrical device or component prior to servicing.
- Unplug the unit or use proper lock-out procedures so that no one can inadvertently turn the power on while you are working on that equipment.
- Use caution when maintaining any piece of equipment.
- Wear protective clothing and eyewear when using power tools.
- Direct discharge of high-pressure water and chemicals away from you and other persons, or direct it into approved containers.
- Keep equipment clean for proper operation.
- Keep hands or any body parts away from equipment while in operation.
- If you need to disassemble a part for service or repair, re-assemble equipment according to instructions.
- Be sure all components are firmly screwed or latched into position.
- Observe safety and handling instructions of the chemical manufacturers.
- Wear protective clothing and eyewear when dispensing or working with chemicals or other potentially hazardous materials.

### 2.1 Cautions, Warnings, and Notes

Throughout this manual, there are various messages concerning safety – please heed these warnings! The following sections give some examples of these safety messages.

### 2.1.1 Cautions

Cautions warn against a potential hazard that, if not avoided, may result in minor or moderate injury. Caution signs also alert against unsafe practices that may cause property damage.



**CAUTION: *DO NOT TOUCH THE BLUE BUTTON! IT IS THE SYSTEM BUTTON AND USED FOR CONFIGURATION.***

### 2.1.2 Warnings

Warning messages warn against a potential hazard that, if not avoided, may result in serious injury or death.



**WARNING: *DO NOT REMOVE PLUGS UNDER ELECTRICAL POWER. MAIN ELECTRICAL POWER MUST BE SHUT OFF BEFORE DISCONNECTING OR CONNECTING ANY PLUG OR CABLE ON THE SPRAY HEAD.***

### 2.1.3 Notes

Note means reader take note. Notes contain helpful suggestions.

**NOTE:** *This parameter should NOT be changed when attempting to make system adjustments.*

## 3.0 Installation

The following information is a suggested means for installation of the XT HCRP Brush. It is understandable not all installations are the same, nor accomplished with the same ease. Therefore, many of your own ideas, experiences, and installation tricks are encouraged and should be implemented.

Prior to the actual installation an on-site visit and observations are recommended. This is especially true if the location is other than new and/or not of Hanna design. Check for the local utilities, making sure of proper access location and supply sizing. If anything must be changed, do so prior to the day of installation. Deficiencies discovered at the time of installation will greatly delay the project.

### 3.1 Installation Requirements

- Water: Customer is to provide and install a  $\frac{3}{4}$  in. water line at 60 psi (nominal).
- Hydraulic: Customer is to provide and install a proper hydraulic power system.
- Hydraulic flow should be at 3 gallons per minute.

### 3.2 General Requirements

Before getting started, you must find the proper location for your new Hanna XT HCRP Brush. We recommend a minimum for length of 5 ft. (2.13 m) clear area for proper operation. The clear area is defined as any space that allows the brush to operate freely, but will not interfere with or be interfered with by other devices.

### 3.3 Installation

1. **Read** this manual prior to opening crates or installing equipment.
2. Carefully open crates and identify the individual parts for assembly using the enclosed check list. If there are any missing parts, notify your Hanna distributor immediately (see warranty information in Chapter 3.0).





**WARNING: WHEN USING A FORKLIFT TO INSTALL EQUIPMENT MAKE SURE TO FOLLOW OSHA AND GENERAL SAFETY RULES AND REGULATIONS TO ENSURE PERSONAL SAFETY.**

3. Place the components in the wash bay as shown on the XT HCRP Brush layout. When all pieces for your configuration have been set in place, take the time to recheck all the layout dimensions using your conceptual drawing.
4. Install each arm onto the post legs and tighten all u-bolts. If you have a freestanding component you will need to install the post weldments first.
5. Install the core weldment assemblies on the arms (without cloth panels).
6. Make sure that the rubber stop prevents the arm from fully retracting to the point where the shock becomes fully closed.
7. Make sure the components are assembled correctly and leveled.
8. Install all hydraulic lines and fittings. Be sure to read Section 3.5 for proper installation of A-LOK fittings.



**WARNING: FAILURE OR IMPROPER SELECTION OR IMPROPER USE OF HOSE, TUBING, FITTINGS, ASSEMBLIES, OR RELATED ACCESSORIES CAN CAUSE DEATH, PERSONAL INJURY, AND PROPERTY DAMAGE.**

9. Connect hydraulic lines (both pressure and return) from your brush to your hydraulic power unit.
10. Connect water lines to your water system. Connect water solenoid to manifold with provided hoses and clamps.



**WARNING: MAIN ELECTRICAL POWER MUST BE SHUT OFF BEFORE DISCONNECTING OR CONNECTING ANY PLUGS OR WIRES IN THE CONTROL BOX.**

11. Connect (electrically) the hydraulic solenoid (provided with the hydraulic unit) and the water solenoid to the car wash controller.
12. Do NOT install the cloth panels at this time.
13. Operate the brush without cloth panels. Start the hydraulic flow slowly, and gradually increase flow until operating speed is reached. Motor speed for the brushes is 75 RPM (for cloth). The diver side should turn clockwise while the passenger side should turn counter clockwise.
14. Check for hydraulic leaks and smooth operation. Repair all hydraulic leaks and re-check operation.
15. If all hydraulic leaks are repaired, install cloth panels as displayed in layout drawing.
16. Check for smooth operation.

### 3.4 RPM Adjustment

For proper operation, brushes must rotate in the direction shown in the layout drawing and operate at the proper RPM.

To estimate the RPM of a brush, count the number of rotations in 15 seconds then multiply by 4. To increase or decrease RPM, use the proper hydraulic priority valve for the brush. Loosen the thumb screw and move the handle to achieve desired RPM. Tighten the thumb screw.

### 3.5 Hydraulic Fitting Assembly and Remake (A-LOK™) for Pressure Compensated Hydraulic Power Units

Stainless steel A-LOK (non-flared) fittings are used on Hanna's pressure compensated hydraulic power units. These fittings consist of four precision engineered parts designed to provide secure leak-proof joints capable of handling high-pressure applications. The tube fittings are completely assembled and ready for immediate use. Simply insert the tube until it bottoms in the fitting body. (If the fitting is disassembled, note that the small tapered end of the ferrule(s) go into the fitting body.)



**WARNING: FAILURE OR IMPROPER SELECTION OR IMPROPER USE OF HOSE, TUBING, FITTINGS, ASSEMBLIES, OR RELATED ACCESSORIES CAN CAUSE DEATH, PERSONAL INJURY, AND PROPERTY DAMAGE.**

If you need to assemble the A-LOK fitting, follow these steps:

1. Tighten nut finger tight.
2. Then tighten nut (with wrench) an additional 1-1/4 turns for 1/4 in. to 1 in. size fittings (6 mm to 25 mm). For 1/16 in., 1/8 in., 3/16 in., 2 mm, 3 mm, and 4 mm size tube fittings only wrench 3/4 turn from finger tight position. Be sure to hold the fitting body with a second wrench to prevent body from turning. It is also helpful to mark the nut to accurately count the number of turns.
3. If you have an inspection gauge, select the proper size inspection gauge and try to place it between the nut and the body hex. If gauge does not fit at any point between them, you have correctly tightened the nut. If you can slip the gauge into the space, the fitting is not properly made up, and you must repeat the assembly procedure.
4. For maximum number of remakes, mark the fitting and nut before disassembly. Before, retightening, make sure the assembly has been inserted into the fitting until the ferrule seals in the fitting. Retighten the nut by hand. Rotate the nut with a wrench to the original position as indicated by the previous marks lining up. (A noticeable increase in mechanical resistance will be felt indicating the ferrule is being re-sprung into sealing position.)

A disassembled joint can be remade simply by retightening the nut to the position of the original make up. If you need to remake the A-LOK fitting, follow these steps:

1. A disassembled joint can be remade simply by retightening the nut to the position of the original make up. For maximum number of remakes, mark the fitting and nut before disassembly.
2. Before retightening, make sure the assembly has been inserted into the fitting until the ferrules(s) seats in the fitting.
3. Retighten the nut by hand.
4. Rotate the nut with a wrench to the original position as indicated by the previous marks lining up. (A noticeable increase in mechanical resistance will be felt indicating the ferrule is being re-sprung into sealing position.)
5. Then snug the nut 1/4 turn as shown from A to B (Figure 4-1), past the original position. Only after several remakes will it become necessary to advance the nut slightly past the original position.

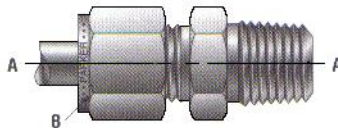

**Figure 3-1 A-LOK Fitting Remake**

**NOTE:** A-LOK<sup>TM</sup> tube fitting part numbers use symbols to identify the size, style, and material. Tube and pipe thread sizes begin with a number indicating their size in sixteenths of an inch. For example, 4=4/16 in. or 1/4 in., 16=16/16 in. or 1.

### 3.6 Hydraulic Fitting Torque (Triple-LOK™) for Fixed Displacement Hydraulic Power Units

Stainless Steel Triple-LOK (37° JIC or commonly referred to as flared) fittings are mainly used on Hanna's fixed displacement hydraulic power units. The fittings are completely assembled and ready for immediate use. Table 3-1 gives the torque values for Triple-LOK (JIC) fittings.

**Table 3-1 Triple-LOK Assembly Torques and FFWR**

SAE Dash Size	Thread Size	Assembly Torque <sup>1</sup> (+10% -0)		Tube Connection FFWR <sup>2</sup>	Swivel Nut or Hose Connection FFWR <sup>2</sup>
		in. lb.	ft. lb.		
-2	5/16-24	35	2	--	--
-3	3/8-24	65	5	--	--
-4	7/16-20	130	11	2	2
-5	½-20	165	14	2	2
-6	9/16-18	235	20	1-1/2	1-1/4
-8	¾-16	525	43	1-1/2	1
-10	7/8-14	650	55	1-1/2	1
-12	1-1/16-12	950	80	1-1/4	1
-14	1-3/16-12	1200	100	1	1
-16	1-5/16-12	1400	115	1	1
-20	1-5/8-12	1900	160	1	1
-24	1-7/8-12	2250	185	1	1
-32	2-1/2-12	3000	250	1	1
-40	3-12	--	--	1	1

1. Torque values are for unlubricated carbon steel components and properly lubricated stainless steel components. For brass fittings, use approximately 65% of the torque values shown, unlubricated. For stainless steel, a lubricant such as Permatex Anti-Seize is recommended to prevent galling.
2. The "Flats from Wrench Resistance" or "Flats" method is recommended for steel, stainless steel, and brass components.

### 3.7 Hanna Hydraulic Tubing Color Code

Hanna uses colored tape on all hydraulic tubing at the factory. Figure 3-2 shows the color code on all Hanna hydraulic operated equipment.



**HANNA**

HYDRAULIC TUBING COLOR CODE	
EQUIPMENT	COLOR CODE
Pressure Line	1 Stripe 
Return Line	2 Stripes 
Wraparound 98-C or Flex	Black 
Tire Washer	Brown 
HCRP	White 
Auto Prep	Purple 
SHWW or ASWW	Green 
Mitter Any Model	Blue 
Top Washer or Any Mitter	Yellow 
<b>SPARE COLORS</b>	
Also Code the Following:	
Superwave, High PSI Arch	Red 
and Any 2nd Brush in Syst.	Orange 
<b>Multi Equipment Combo's</b>	
1st Mitter in System	Blue 
2nd Mitter	Yellow 
3rd Mitter	Red 
1st ASWW in System	Green 
2nd ASWW	Orange 
3rd ASWW	Red 

Figure 3-2 Hanna Hydraulic Tubing Color Code

This page intentionally left blank.

## 4.0 Parts and Maintenance

### 4.1 General Maintenance

The XT HCRP Brush requires periodic inspection and maintenance. However, there are only a few items that should be inspected on a regular basis. For the first month of operation check, on a weekly basis, hardware for tightness on pivot arms, bearings, vertical-mount legs, brush cores, motor couplings, stop collars, and hydraulic-motor mounts.

#### 4.1.1 Daily Maintenance

- ✓ Check the wash panels for tears in the cloth (if any are torn, correct this by cutting the torn portion out in a “half moon” shape cut)
- ✓ Check the unit for proper operation prior to washing the first vehicle each day
- ✓ Check spray nozzles for proper delivery of water on the wash panels
- ✓ Check hydraulic lines for leaks
- ✓ Check water solenoid valve for positive on/off operation

#### 4.1.2 Weekly Maintenance

- ✓ Check bearings for proper operation and smooth movement
- ✓ Grease the four pillow block bearings
- ✓ Check for free movement on spring and shock assemblies
- ✓ Check arms for proper alignment and proper position on shafts
- ✓ Check frame, legs, and cross beams for cleanliness



### 4.1.3 Monthly Maintenance

- ✓ Check hydraulic lines and water hoses for wear or rub
- ✓ Check frame, legs, and cross beams for cracks and loose bolts
- ✓ Check and tighten hard stops as needed
- ✓ Check spray nozzles for wear
- ✓ Check all bearings for wear

## 4.2 Lubrication

Any lubrication program is only as good as the lubricants used. So we suggest you review this information and stock up on the best lubricants available.

It is recommended that once you decide on a type of lithium grease that you stick to the same type of lithium grease when you lubricate your bearings.

Use only one or two pumps of grease per bearing. If grease comes out of the seals this is too much and may damage the seal letting water into the bearing.

Weekly: Lubricate bearings using high-quality multi-purpose lithium grease.

### 4.3 Spare Parts List

Table 4-1 shows the recommended spare parts to be kept on hand by the Distributor and Owner/Operator.

**Table 4-1 Recommended Spare Parts List**

<b>Recommended Parts</b>	<b>Part Number</b>	<b>Distributor Carries Part In Stock</b>	<b>Owner/Operator<sup>1</sup> (Distributor Support) Carries Part In Stock</b>	<b>Owner/Operator<sup>2</sup> (No Distributor Support) Carries Part In Stock</b>
Bearing, Arm Bracket	010439	NO	NO	NO
Rubber Stop	228536	YES	NO	YES
Spring & Shock Assy.	810728	YES	YES	YES
Motor, Hydraulic <small>For Fixed Displacement Units</small>	366066	YES	NO	YES
Motor, Hydraulic <small>For Pressure Comp. Units</small>	366906	YES	NO	YES
Panel Insert, 21 in.	760884	NO	NO	NO
Panel Insert, 28 in.	760892	NO	NO	NO
Panel Insert, 35 in.	760900	NO	NO	NO
Retract Cylinder Assembly	813004	NO	NO	NO
Jet, Nylon, ¼ in. MPT	021899	YES	NO	NO
Core Weldment, 10 x 21	763003	YES	NO	NO
Core Weldment, 10 x 28	800151	YES	NO	NO
Core Weldment, 10 x 35	763037	YES	NO	NO

1. Recommends what spare parts should be kept on hand by the Car Wash Owner/Operator if there is close support from the distributor and parts are quickly obtainable.
2. Recommends what spare parts should be kept on hand by the Car Wash Owner/Operator if there is NOT close support from the distributor and parts are NOT quickly obtainable.

## 4.4 Recommended Tool Kit

Table 4-2 shows the recommended tools for installation and maintenance of your system.

**Table 4-2 Recommended Installation Tools**

1/2 in.	Open-End Box Wrench
9/16 in.	Open-End Box Wrench
3/4 in.	Open-End Box Wrench
7/8 in.	Open-End Box Wrench
15/16 in.	Open-End Box Wrench
1/8 in.	Ball-End Hex Bit T-Wrench (Allen Wrench)
5/32 in.	Ball-End Hex Bit T-Wrench (Allen Wrench)
3/16 in.	Ball-End Hex Bit T-Wrench (Allen Wrench)
1/4 in.	Ball-End Hex Bit T-Wrench (Allen Wrench)
12 in.	Adjustable Wrench
10 oz	“Dead Blow” Plastic Mallet
12 in.	Adjustable Wrench
Full Set	1/2 in. Drive Sockets
Full Set	3/8 in. Drive Sockets

## 5.0 Troubleshooting

This chapter helps you solve common brush problems. If you are still unable to find a solution after reading through this section, please call your distributor for technical assistance.

### 5.1 Brush Problems

<u>Problem</u>	<u>Possible Solutions</u>
<ul style="list-style-type: none"> <li>▪ BINDING OR JUMPING</li> </ul>	<ul style="list-style-type: none"> <li>▪ Check bearings for wear</li> <li>▪ Check shaft for alignment</li> <li>▪ Check arms for alignment</li> <li>▪ Check for proper RPM</li> <li>▪ Check back-pressure relief valve</li> <li>▪ Check hydraulic motor</li> </ul>
<ul style="list-style-type: none"> <li>▪ UNIT WILL NOT – STOP/START</li> </ul>	<ul style="list-style-type: none"> <li>▪ Check hydraulic solenoid valve</li> <li>▪ Check computer functions</li> <li>▪ Check hydraulic motor</li> <li>▪ Check for hydraulic leaks</li> </ul>
<ul style="list-style-type: none"> <li>▪ WATER WILL NOT SHUT-OFF</li> </ul>	<ul style="list-style-type: none"> <li>▪ Check valve diaphragm</li> <li>▪ Check water solenoid valve for sticking</li> <li>▪ Check for contamination in solenoid valve</li> </ul>
<ul style="list-style-type: none"> <li>▪ SQUEAKING</li> </ul>	<ul style="list-style-type: none"> <li>▪ Lubricate bearings with a high-quality Lithium grease</li> </ul>
<ul style="list-style-type: none"> <li>▪ BRUSH ROTATES IN WRONG DIRECTION (LEFT SIDE ROTATES COUNTER CLOCKWISE AND RIGHT SIDE ROTATES CLOCKWISE)</li> </ul>	<ul style="list-style-type: none"> <li>▪ Hydraulic pressure and return lines reversed</li> </ul>

## 5.2 Hydraulic Fitting Problems

<ul style="list-style-type: none"> <li>▪ TUBE NUT CONTINUES TO BACK OFF OR LOOSEN</li> </ul>	<ul style="list-style-type: none"> <li>▪ Excessive vibration can cause the 37° tube flare nut to back off from the fitting body. Consider better tube line routing and clamping to protect the fitting/tube union or control the system vibration.</li> </ul>
<ul style="list-style-type: none"> <li>▪ FLARE ON TUBE FITTING IS COLLAPSED</li> </ul>	<ul style="list-style-type: none"> <li>▪ 37° fittings are susceptible to over torque. Once the tube fitting has been over torqued the sealing capability is nearly gone. Additional tightening on the tube/hose joint will only cause additional leakage. Replace fitting and retighten with appropriate torque or FFWR method.</li> </ul>
<ul style="list-style-type: none"> <li>▪ DAMAGED FITTING</li> </ul>	<ul style="list-style-type: none"> <li>▪ Due to repeated use, abuse, handling, etc., the 37° flare fittings are susceptible to damage on the flare end of the fitting. These problems can often be avoided by proper handling and storage, including keeping plastic fitting caps and plugs on until fitting is used.</li> </ul>
<ul style="list-style-type: none"> <li>▪ TUBE IS OVER FLARED OR UNDER FLARED</li> </ul>	<ul style="list-style-type: none"> <li>▪ If tube is over flared the tube nut will not be able to engage fitting body or not be able to swivel freely. If tube is under flared, the possibility for tube blow off is greatly increased and the sealing area is greatly reduced. Re-flare to appropriate flare O.D. specifications as outlined in this catalog.</li> </ul>
<ul style="list-style-type: none"> <li>▪ POCK MARKS ON FLARE I.D.</li> </ul>	<ul style="list-style-type: none"> <li>▪ Tube end not deburred or cleaned properly before flaring.</li> </ul>

<ul style="list-style-type: none"> <li>▪ LEAKAGE – TUBE MISALIGNMENT OR IMPROPER FIT</li> </ul>	<ul style="list-style-type: none"> <li>▪ Align the flared tube end and the connecting tube fitting before tightening the tube nut. Ensure that the tubing is bent to the appropriate bend angles. Do not “force” the tube assembly into position. Use two wrenches during assembly.</li> </ul>
<ul style="list-style-type: none"> <li>▪ LEAKAGE – IMPROPER TIGHTENING</li> </ul>	<ul style="list-style-type: none"> <li>▪ Check the joint for appropriate tightness. Re-torque or use the FFWR method of assembly to ensure appropriate joint makeup. If leakage persists, it could be a problem listed below.</li> </ul>
<ul style="list-style-type: none"> <li>▪ LEAKAGE – TUBE CRACKED ALONG FLARE</li> </ul>	<ul style="list-style-type: none"> <li>▪ Poor quality tube, work-hardened tube, or faulty tube preparation can cause the tube to crack. Re-flare while addressing the aforementioned issues. Do not use a tube cutter with steel and stainless steel tube, as tube cutters tend to “work harden” the tube before flaring.</li> </ul>
<ul style="list-style-type: none"> <li>▪ LEAKAGE – TUBE SEALING SURFACE HAS IMPERFECTION CAUSING LEAKAGE BETWEEN TUBE FITTING AND TUBE FLARE</li> </ul>	<ul style="list-style-type: none"> <li>▪ Low quality welding tube often will leave a weld bead causing a leak path between the fitting and tube flare. Use a high-quality seamless or welded and redrawn type of tube. Problems with the flaring tooling can also cause a surface imperfection on the sealing surface of the tube flare as well. Flare cones/burnishing heads, when damaged can cause these imperfections in the mating tube flare. Re-flare while addressing the aforementioned problem areas.</li> </ul>

This page intentionally left blank.