

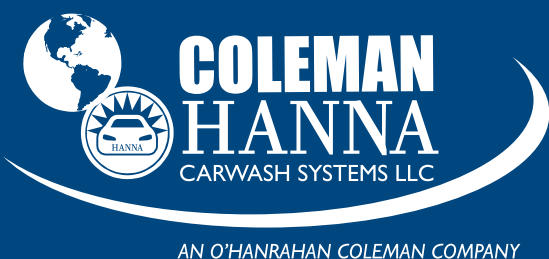

High Pressure Pumping *Installation Manual*



5842 W 34th St • Houston, TX 77092

1.800.999.9878 1.713.683.9878

www.colemanhanna.com



Find us on Facebook:
[/ColemanHannaCarwash](https://www.facebook.com/ColemanHannaCarwash)



TABLE OF CONTENTS

| | |
|--|----|
| Sparkle Equipment Planning And Arrangement | 2 |
| Sparkle Water Softener Installation | 3 |
| Sparkle Tank And Heater Installation | 4 |
| Sparkle Super Saver Installation..... | 5 |
| Sparkle Reverse Osmosis Unit..... | 6 |
| Sparkle Reverse Osmosis Unit Installation..... | 7 |
| Sparkle Meter And Safe Installation..... | 8 |
| Boom Installation..... | 9 |
| Line Installation | 10 |
| Air Compressor Installation | 11 |
| Sign Installation..... | 12 |
| Sparkle Reverse Osmosis Check-Out On Procedures..... | 14 |
| Sparkle Reverse Osmosis Turn On Procedures..... | 15 |
| Sparkle Reverse Osmosis Unit Ratings..... | 16 |
| Sparkle Super Saver Turn On Procedure..... | 17 |

**** READ MATERIAL SAFETY DATA SHEETS
BEFORE HANDLING PLUMBING CHEMICALS**

SPARKLE EQUIPMENT PLANNING AND ARRANGEMENT

Before any operation can be carried out there must be a time of planning. This is no different for the installation of car wash equipment. Carefully plan the equipment lay out and set up before starting installation process.

Certainly one of the first things that must be done is the uncrating of all equipment. Inspect each component for visible damage.

NOTE: If there is any damage to any boxes or crates, carefully inspect and evaluate the damage. Report any damage to the freight carrier immediately.

In the planning process, careful consideration should be made concerning the equipment room layout. Make the necessary utilities convenient to each piece of equipment.

This manual is assembled in a suggested installation manner. Located in the back is 3 sheets of equipment layout drawings. They should be used in assistance of equipment hook-up.

Completely read through this manual prior to beginning installation. This will enable the individual to understand each system and it's installation procedure.

<<< CAUTION >>>

The installation of this equipment involves High Pressure, Liquid or Natural Gas, and High/Low Voltage. Trained personnel should only be used in its hook-up.

SPARKLE WATER SOFTENER INSTALLATION

1. The first system that needs to be hooked-up in the car wash is the WATER SOFTENER AND BRINE TANK ASSEMBLY.

NOTE: A licensed plumber should be involved in this installation.

2. After thoroughly cleaning the area that the water softener is to be positioned at, move into place the unit and brine tank. Install unit as close to the incoming water supply as possible.
3. Plumb the water softener into the system as recommended by the plumbing blueprint, supplied with this manual.
 - a. Connect incoming water supply in water softener.
 - b. Supply outgoing softened water to water heater and Super Saver.

NOTE: Bypass valves must be installed to prevent car wash from being shut down in case water softener has to be serviced or replaced.

4. Plug 110-Volt cord into duplex receptacle provided by AN electrician.
5. Do to a wide variety of available water softeners, please consult the owner's manual provided with the softener to correctly set the clock or water meter.
6. Water softener installation is now completed.

SPARKLE TANK AND HEATER INSTALLATION

1. After uncrating the heater, clean out the area in which the heater will be positioned in the equipment room.
2. Set the heater about 6-8" from the wall and insure it has good ventilation all around.
3. Most heaters will consist of a boiler, insulated tank, and circulation pump. (Please refer to the owner's manual provided with the heater for proper hook-up).
4. The plumber must bring cold, soft water from softener to heater, then pipe hot soft water to Super Saver tank.
5. The electrician will need to provide 110V single phase 20 Amp service to the heater and circulation pump.

SPARKLE SUPER SAVER INSTALLATION

1. After thoroughly cleaning the equipment room, position the Super Saver approximately 12-18" from the wall.
2. On the bottom of the frame are leveling bolts so that you can level the unit as much as possible.
3. The unit consists of all of your high pressure and low-pressure functions with control panels.
4. Instruct your plumber to provide hot soft water to the hot water tank, and cold soft water to the rinse manifold and chemical tanks. He will need to provide a 1" hot soft water line and a 3/4" cold soft water line to rinse the manifold.

Backflow prevention is required for this equipment. This unit does not include any backflow prevention devices. Please install a suitable, approved backflow device at the incoming water supply into the building.

5. This unit must be hooked up by a qualified electrician. A suitable copper grounding conductor must be attached to the grounding bar that is located in the bottom of the control panel. All current-carrying conductors must be copper.
6. The electrician should provide an individual 3-phase circuit to the large control panel for each pump. He will need to tie the 3-phase power into the top of each motor starter.

*If your unit has a 3 HP motor, the load is 9.2 Amps per bay, or a 20 Amp breaker.

*If you have a 5 HP 3 phase motor, the load is 13.0 Amps per bay, or a 30 Amp breaker.

In addition to the bays, the electrician will need to provide a 110V single-phase control circuit to the 500 VA transformer that is located in the bottom of the panel. The circuit breaker must be a 15 or 20 Amp breaker for the transformer. The 110V circuit must be connected to the primary side of the transformer. If your unit has Spot Free Rinse, please provide a 220V single- phase 20 Amp breaker to the motor starter for this function. After all wiring is complete make sure to plug all unused knockouts.

The following chart shows HP breaker size and wire size:

| HP | Phase | Breaker | Wire Size |
|----|-------|---------|-----------|
| 3 | 1 | 30 Amp | 10 |
| 5 | 1 | 40 Amp | 8 |
| 3 | 3 | 20 Amp | 12 |
| 5 | 3 | 30 Amp | 10 |

DO NOT TURN POWER ON AT THIS TIME

SPARKLE REVERSE OSMOSIS UNIT

System Description

The Sparkle Reverse Osmosis (Spot Free Rinse System) is engineered with the best available components on the market to deliver low pressure spot free water to the car wash bays. The system can be installed on any existing car wash, as well as, new installations. Years of trouble free service, with little maintenance, can be expected. The following equipment is included in your Sparkle Reverse Osmosis Pumping and Storage Unit.

1. Fiberglass Product Water Storage Tank
2. Blue Charcoal Filter
3. Chlorine Test Kit
4. 10' 3/4" Product Hose
5. R.O. Owner's and Installation Manual.

The following should be installed for the R.O. Unit by its appropriate installer:

1. 220 Volt Single-Phase electricity, ground and other electrical hook-ups as required by local Electrical Codes and City Ordinances.
2. 1/2" Water Supply Line. This line should be taken off of the existing water softener to provide softened water to the R.O. Unit.

NOTE: If the water supplied to the R.O. Unit is 50° F, then hot and cold water must be blended together to provide a consistent water temperature between 70° and 90° F.

3. 1/2" Drain Line.
4. A clean 34" x 34" x 79" floor and working space for the R.O. Unit and Fiberglass Tank.

After the preceding has been provided for the LPS, according to all local, state and national codes and ordinances, the LPS is not ready to be installed.

SPARKLE REVERSE OSMOSIS UNIT EQUIPMENT INSTALLATION

1. Position fiberglass tank in equipment room as close the Super Saver as possible.

NOTE: When installing tank, make sure that the area around the tank is clean and free of dirt and debris, so as not to damage the fiberglass tank.

2. Place blue charcoal filter between softened water supply and R.O. unit. Hook-up incoming water into the inlet side. Turn on water supply and allow unit to flush with water for at least 10 minutes or until water that is coming out of filter outlet that is clean and clear. Turn water supply off.
3. Install a 1/2" hose from the outlet side of the charcoal filter to the inlet hook-up on the R.O. unit. This connecting point is located on the back of the R.O. unit behind the 0-100 psi pressure gauge.
4. On the back of the R.O. unit control panel is a blue 3/8" hose that attaches to the top of the fiberglass tank. This hose provides a route for the spot-free water to get from the R.O. unit to the storage tank.
5. On the back of the R.O. unit control panel is a red 3/8" hose that goes to the 1/2" drain provided for the unit.

NOTE: This water can be returned to the wash tank if desired.

6. Inside the R.O. unit control box is a 4-conductor cable coming from the computer. This control cable goes to the float switch that is located in the fiberglass storage tank. The proper connection sequence is as follows:

Red Lead ----- Lower Float Switch
Green Lead ----- Upper Float Switch
Black Lead ----- Upper and Lower Float
(See Appendix B)

7. Install 3/4" line between the outlet of the fiberglass storage tank (lower fitting) and the inlet side of the delivery pumps (elbow located on top of pump).

SPARKLE METER AND SAFE INSTALLATION

The meter and safes are installed on an individual preference. These are only guidelines.

1. In most cases the meter and safe installation should be accomplished before the bricking of the car wash.
2. Determine the desired set up of meter and safe combination before starting the installation process.
3. The Typical set up is one (1) meter for one (1) safe, or two (2) meters for one (1) safe.
4. The safes should be mounted in a very visible location. This is one of the best deterrents against theft and vandalism.
5. After determining proper heights and attaching points of meter and safes, have a qualified welder weld each item in place.
6. Install 1 1/2" PVC male adapters to meter and safe openings. Route flexible PVC tubing between meter and safe. (See Diagram)
7. Install minimum 1/2" EMT from pre-punched hole in top of meter box to above wall height. This will provide routing for the low voltage control cable to the meter.
8. Hook up a 15-conductor/18-gauge cable from each meter to the control panel on the Super Saver.

This completes the meter and safe installation procedure.

BOOM INSTALLATION

Two booms are provided for each bay. The first boom is the 360° ceiling mounted boom for high and low-pressure functions. The second boom is a 180° wall mounted boom for the foaming brush function.

1. The location of the 360° ceiling boom is not always in the center of the bay. Depending on the size of the bay, it is customary to mount the boom offset to the side where the wand holder will be. This causes the hose to be closer to the wand holder, therefore having less chance of cars catching the hose with their mirrors. Also, it is customary to put about 1/2" of shims on two legs, to make the boom lean toward the wand holder. This will cause the boom arm to return back to a position close the wand holder. Please mount booms with at least a 3/8" bolt to insure good strength for holding up the boom.
2. The 180° boom is normally located on the wall opposite the coin meter. Mount the boom on the wall so that the arm of the boom is not at the same height of the 360° ceiling mount boom. The 180° boom arm is the lower boom. Make sure you check the boom arm swing to insure that it does not interfere with light fixtures, the 360° boom, or other objects.
3. Mount the V-shaped bracket on the wall, noticing that the slotted hole on the bracket is at the bottom. Also, install the boom bracket bumpers at the top hole. You can adjust the slope of the bracket with the slotted holes so that the boom will usually fall in the direction of the flow of traffic through the bay.
4. Mount foam generator on hose feeding the brush boom and boom manifold on the 360°. Install all bay hoses on the booms now, but do not install brushes or trigger guns.

SPARKLE LINE INSTALLATION

According to the selections of the system that is being installed, there must be a delivery line from each product to each bay: high pressure wash, pre-soak, whitewall, foam brush, spot free, etc. The air -line from the whitewall and pre-soak systems can be tied together, and run only one line to boom manifold.

1. Begin the line installation in the equipment room, working from the equipment room out to the farthest bay. (See Diagram)
2. Leave plenty of extra hose at the boom connection for the boom manifold hook-up.
3. Using insulated conduit straps, attach all lines to a stabilized structure of the car wash building.
4. Cut length at equipment room leaving plenty of extra hose for equipment connection.

NOTE: It is a good procedure to separate all hoses for a particular bay and mark accordingly.

5. Continue working to the next farthest bay following the steps 1-4 from above.
6. Attach all hoses to the support structures as they are being installed.

NOTE: If the equipment store room is in between bays, work one side, installing hoses, then proceed to the other side of the equipment room.

AIR COMPRESSOR INSTALLATION

1. Clear out area for air compressor.
2. Remove air compressor from crate.
3. Place compressor in the equipment room 2-4" from wall.
4. Check oil in compressor and fill to its proper level.
5. If the air compressor is an upright model bolt it to the floor.
6. **Instruct the electrician** to run proper size electrical service to air compressor.
7. **Instruct the plumber** to run 1/2" air line from air compressor to Super Saver.
8. Install 3/8" air filter on air- line to remove moisture and debris from the air supply.
9. Hook air hose from Super Saver to air filter.

SIGN INSTALLATION

Please refer to the drawing for proper layout of your signs. Most signs are installed against a brick or masonry wall with plastic nail-in anchors. This anchor does not have a screw, but instead a nail.

1. Place sign on wall, mark holes, and remove sign.
2. Drill holes with masonry gun and 1/4" bit.
3. Place sign in line with holes and nail in anchors with a hammer.

Repeat this procedure for all signs.

SPARKLE REVERSE OSMOSIS UNIT CHECK-OUT PROCEDURE

Before continuing installation, perform the following checks:

1. Turn on water supply valve and check for leaks of any kind. If any are found, turn off the valve, repair leak and retest. The water pressure should read between 20-60 psi, at the 0-100 psi gauge, depending on the city water pressure.
2. Perform chlorine test according to the instructions provided in the test kit. If any trace of yellow is found, re-check installation of charcoal filter for a reversed hook-up. Properly install charcoal filters, and retest. If the charcoal filter is properly installed and the chlorine test fails again then the charcoal filter is defective and must be replaced.

<<< CAUTION HIGH VOLTAGE >>>

3. Check electrical voltage at breaker and verify that 220 Volts single phase is provided to unit.
4. Check that drain hose has been connected from R.O. unit to drain.
5. Check to see if the "run" and "power" lights on the Omron computer are lit.

REVERSE OSMOSIS UNIT TURN-ON PROCEDURE

Now that the Sparkle Reverse Osmosis Unit is installed, Spot Free water can be produced. Turn power on to the R.O. unit and it should start to produce SF water (Product Water). There should be a supply of water going to the fiberglass storage tank and a small amount of water coming out of the drain hose (Reject Water). The pressure gauge on the front of the R.O. control panel will indicate the product supply pump pressure. It should read between 130-195 psi. The unit should run for several minutes, allowing air to escape the system.

Do not make any adjustments until the unit has been turned on for about 10-15 minutes. This unit was factory run and tested and should not need any adjustments, but if needed, proceed as follows:

To adjust the amount of Product Water or Reject Water adjust the regulator. The regulator is located in the middle of the R.O. control panel, for the supply pump. When the regulator is increased (turned clockwise) there will be less flow indicated on the reject flow meter and more flow on the product flow meter.

NOTE: Never exceed 195 psi, or damage will occur to the R.O. Unit pump and membrane.

To properly set the ratio of Product Water to Reject water, adjust the regulator starting out at about 100 psi and increase the pressure in 10-psi increments. You will notice that, even though you keep increasing the pressure, the product water does not increase (only the reject water decreases). At this point, by increasing the pressure, you are only working the membranes harder and harder, but yet not producing any more water. A lot of systems run typically at 150-170 psi.

SPARKLE REVERSE OSMOSIS UNIT RATINGS

Typical recovery rates and settings for a Sparkle R.O. System are as follows:

| System Size | Product Water | | Reject Water | |
|-----------------|---------------|-------------|--------------|-------------|
| | Minimum GPM | Maximum GPM | Minimum GPM | Maximum GPM |
| 500 GPD System | .2 | .4 | .8 | 1.0 |
| 1500 GPD System | .7 | .9 | 1.4 | 1.5 |
| 3200 GPD System | 1.6 | 2.6 | 3.0 | 3.5 |
| 4800 GPD System | 2.5 | 3.0 | 4.0 | 4.5 |

Never exceed the above listed recovery rates or severe fouling will result and membrane warranty will be void. It is best and most economical to have a high rate of reject water, than to take a chance in damaging membranes by pushing the R.O. unit too hard.

If the unit is not producing the anticipated amount of product water, the following factors can usually be contributing to its failure:

- A. TDS (Total Dissolved Solids) above 300 PPM
- B. Water temperature is too cold
- C. Hard water

Once the fiberglass tank has about 2-3' of water, you will need to prime the delivery pump. To do this, simply loosen the hose fitting on the discharge side of the pump, allowing water and air to flow through the pump until all air is purged from the line.

If there are any problems in setting up this unit, or any questions concerning it, contact the factory, 1-800-999-9878 or 1-713-683-9878.

SPARKLE SUPER SAVER TURN-ON PROCEDURE READ ALL MSDS BEFORE HANDLING ANY CHEMICALS PLUMBING

1. Inspect each Hydrominder in each chemical tank for proper metering tip. Position drums of chemical in their proper place and insert hydrominder suction hose.
2. Turn on city water at main valve and purge all air from softener/ heater and lines.
3. When water enters the tank the Hydrominder will dilute the chemical to the proper amount for each service.
4. Once the Super Saver has water in all chemical and hot water tank along with pressure to rinse manifold, you can turn on power to bays.
5. You can now turn on air for air compressor to the Super Saver.
6. Go out to each bay and remove all spray tips and trigger guns from hoses.
7. Select rinse first and turn on each bay. After running the pump on rinse 2-3 minutes, switch to wash, wax and each low-pressure function. Allow each product to thoroughly flush lines.
8. Now install all trigger guns and tips. This will allow pump to build up pressure. The pumps have all been tested at 1000 psi and low-pressure functions have been set. Please refer to the pressure setting chart if adjustments need to be made on low-pressure functions. Keep in mind that this chart is the normal setting, but you can adjust to suit your personal preference. A rule of thumb on low-pressure settings is that air is always 10 psi less than the product it is accompanying. If you have too much air pressure, the symptom will be that the product is very irregular coming out of the trigger gun.
9. Test all coin mechanisms for coin acceptance and all timers for proper operation.
10. It is very important that you test every function on every bay. This will insure that no lines are crossed and that the proper product is being dispensed properly.
11. Once you open up the car wash, please have someone monitoring the location closely for the first several days to insure proper operation.

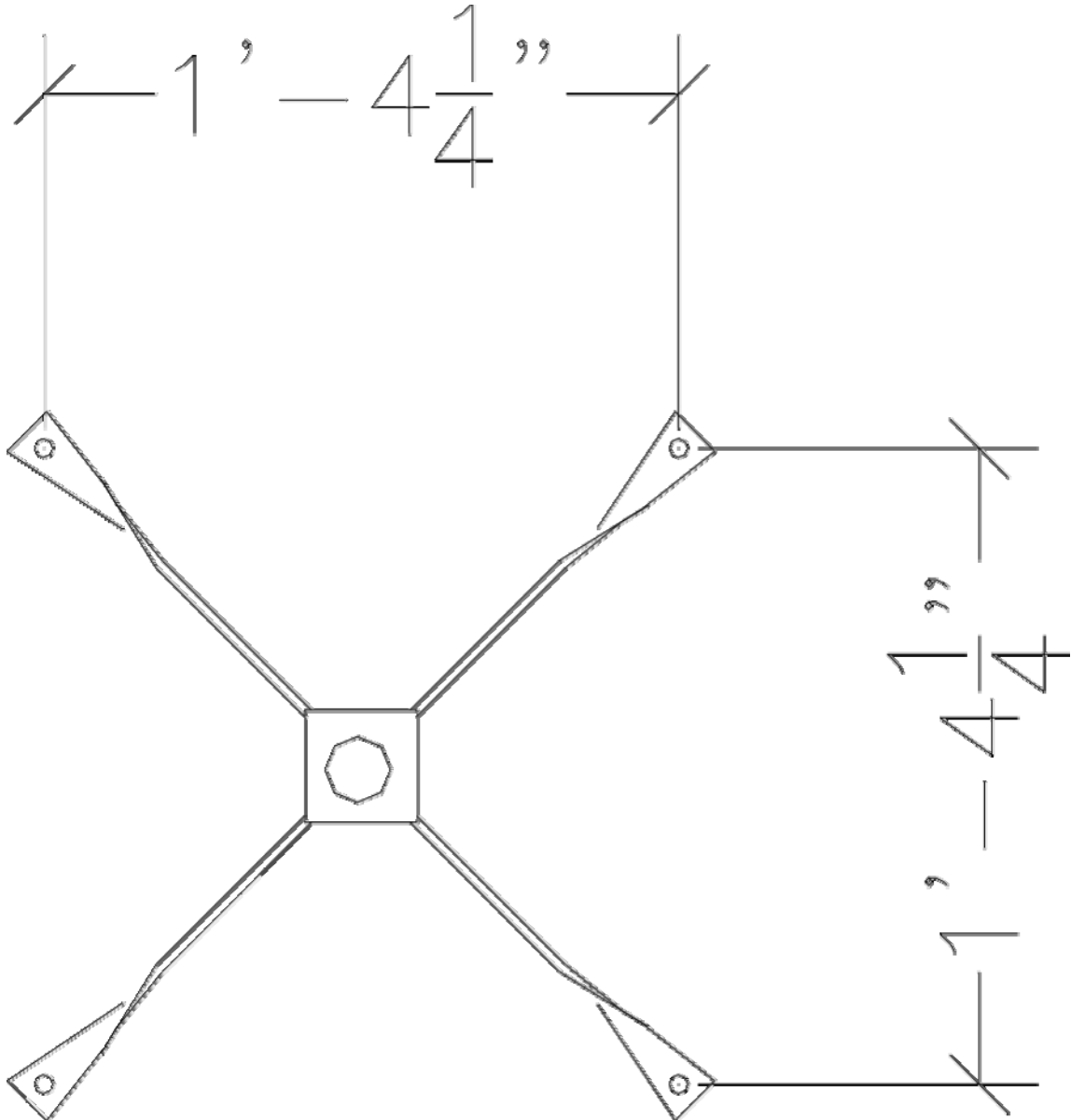

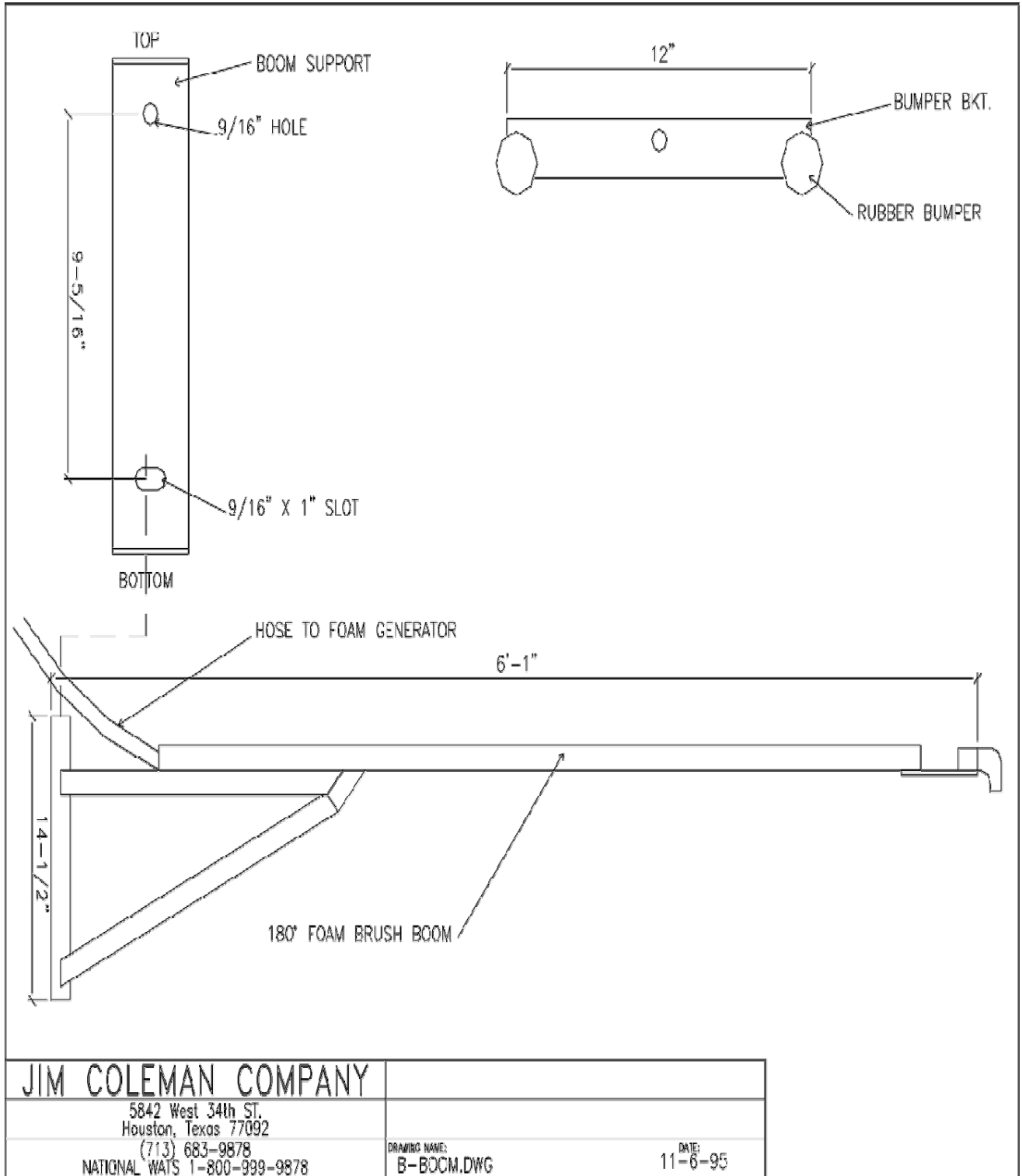

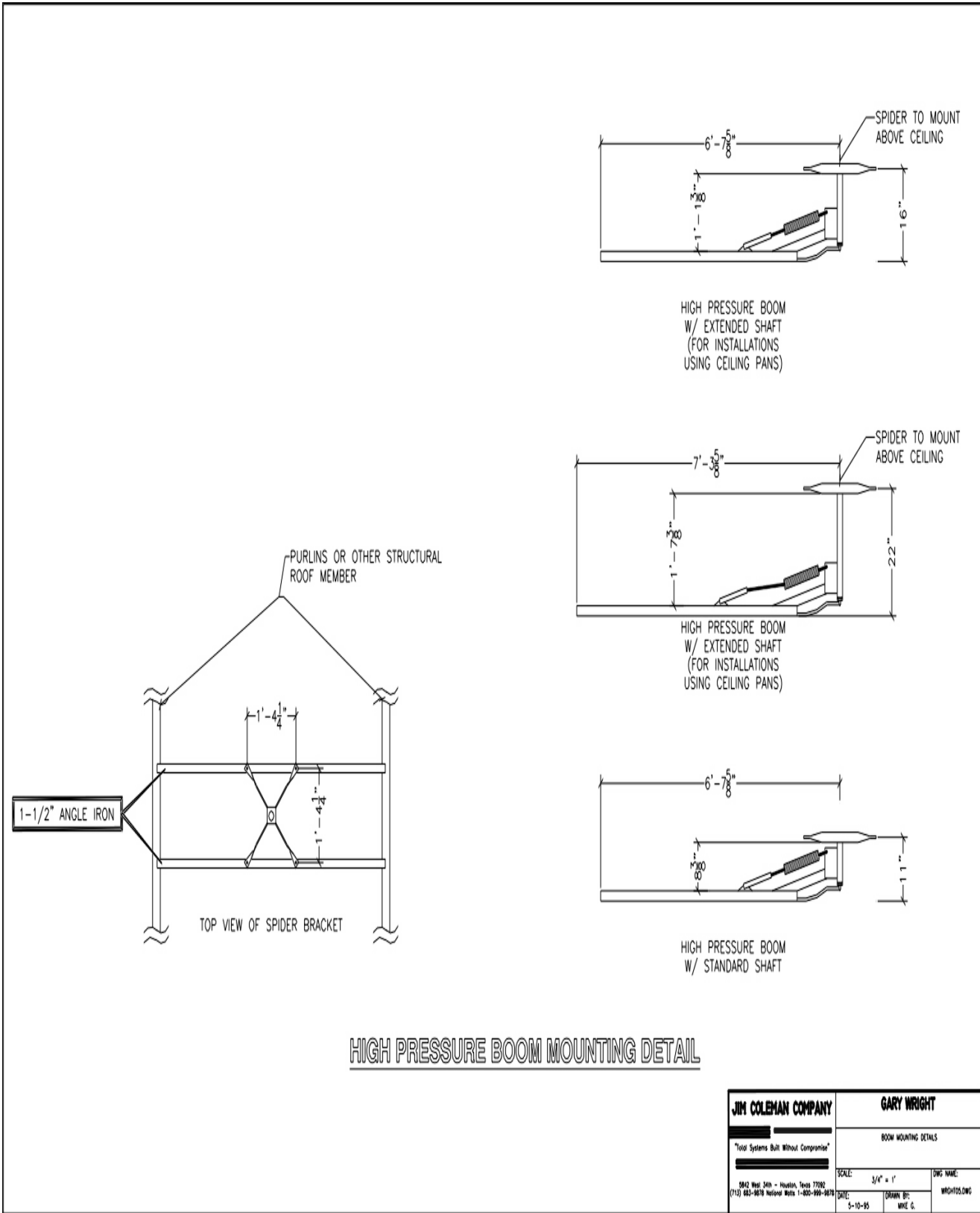

Self Serve Installation/Operation Manual

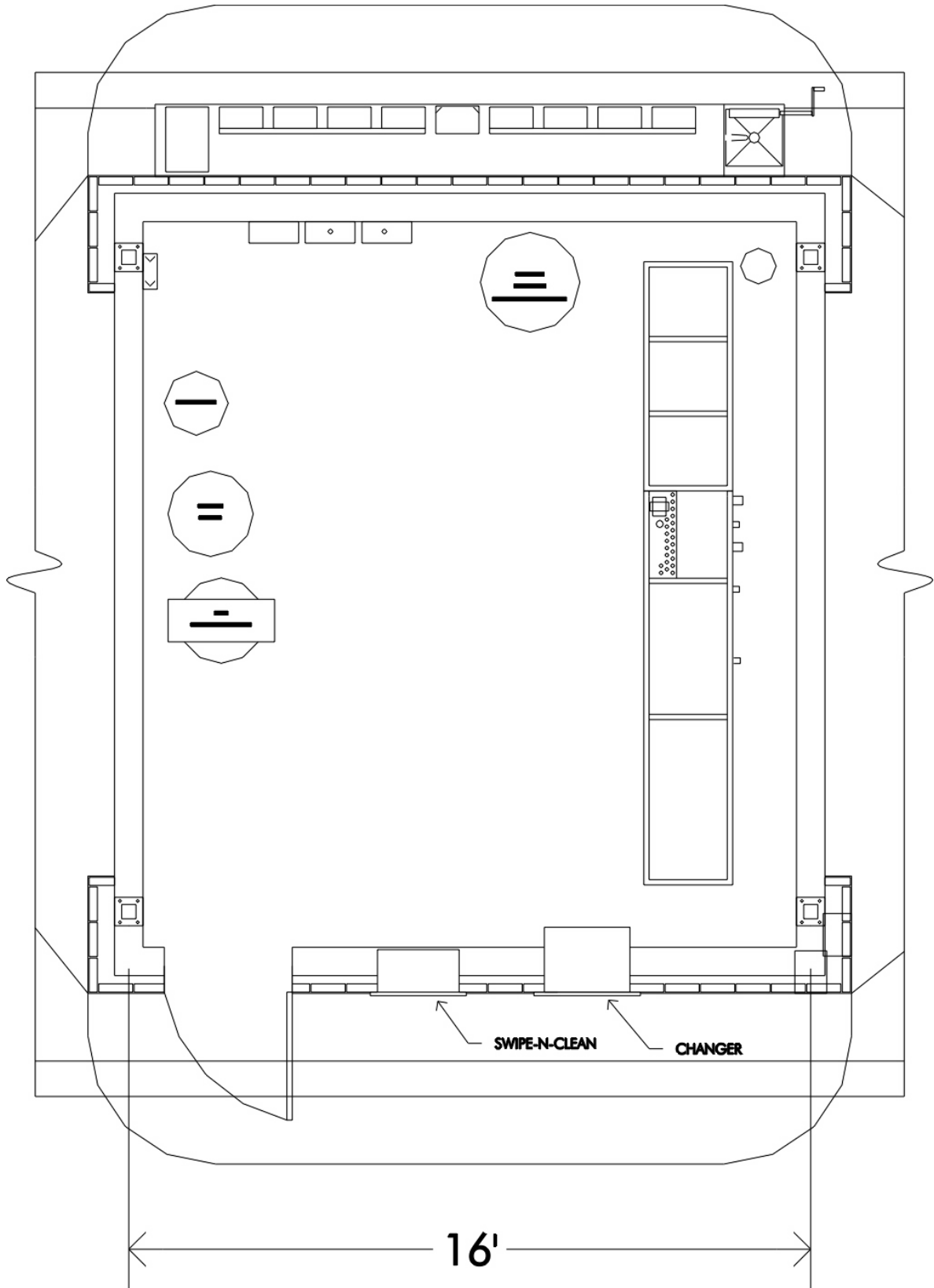

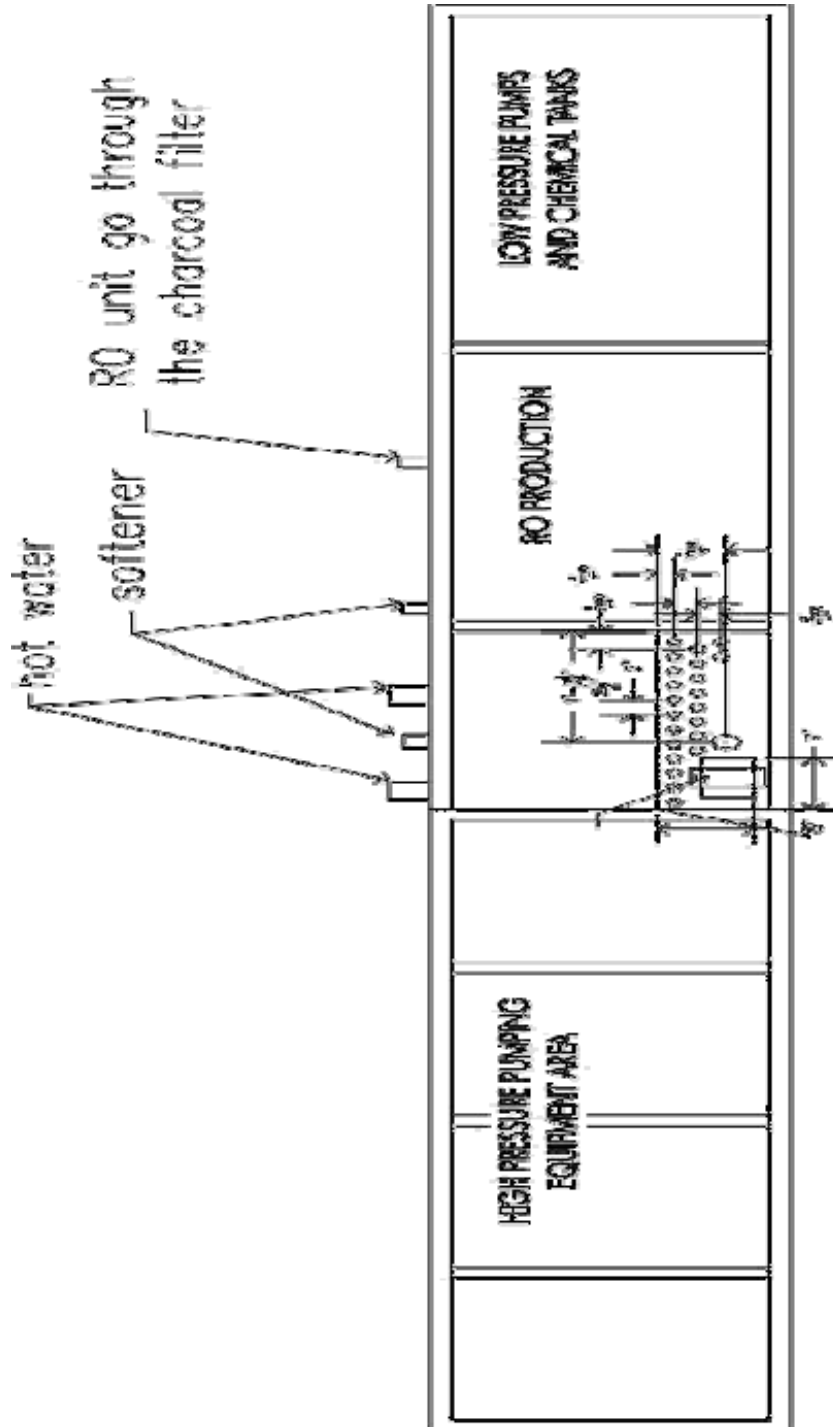

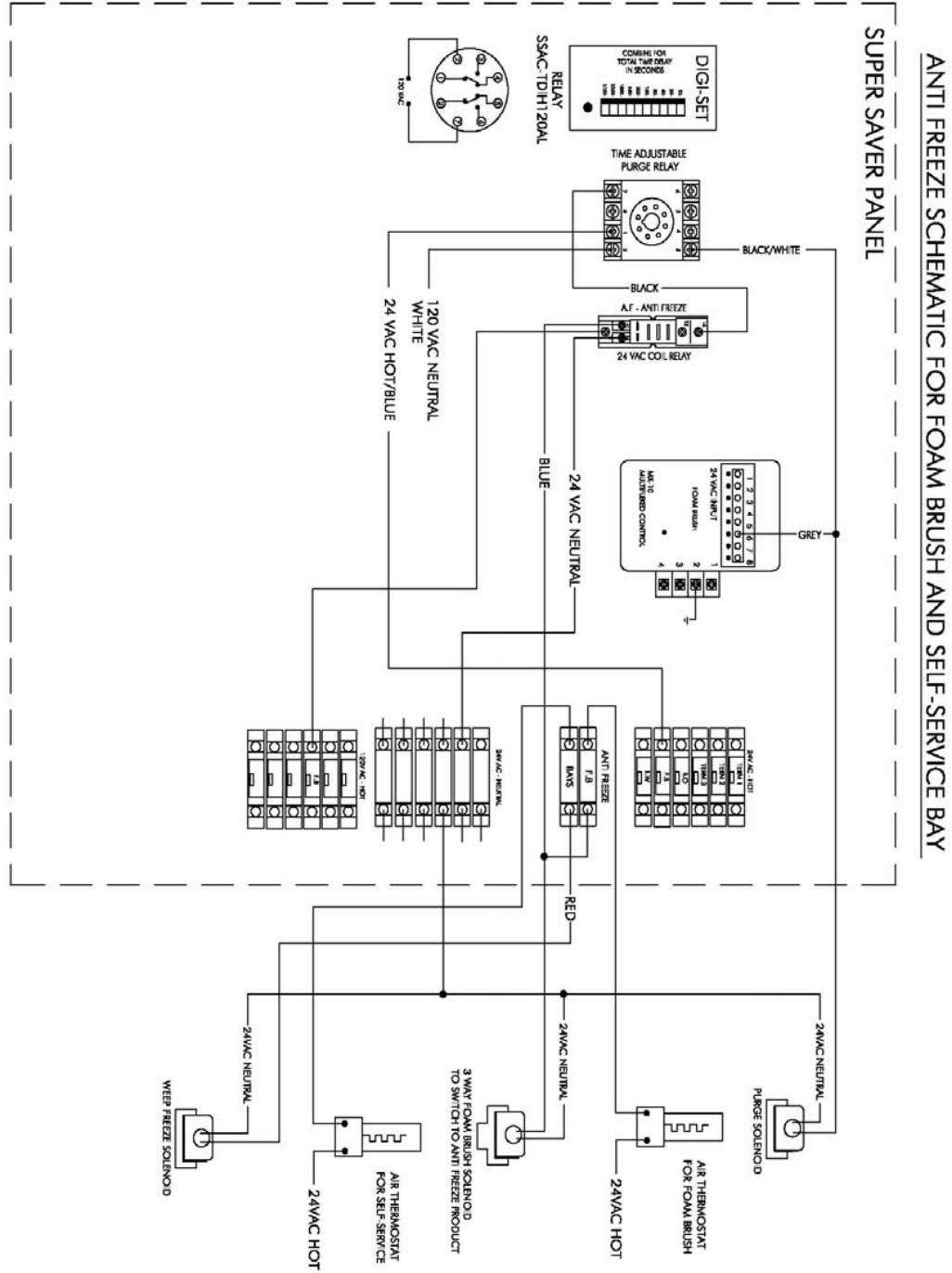

MOTOR STARTER

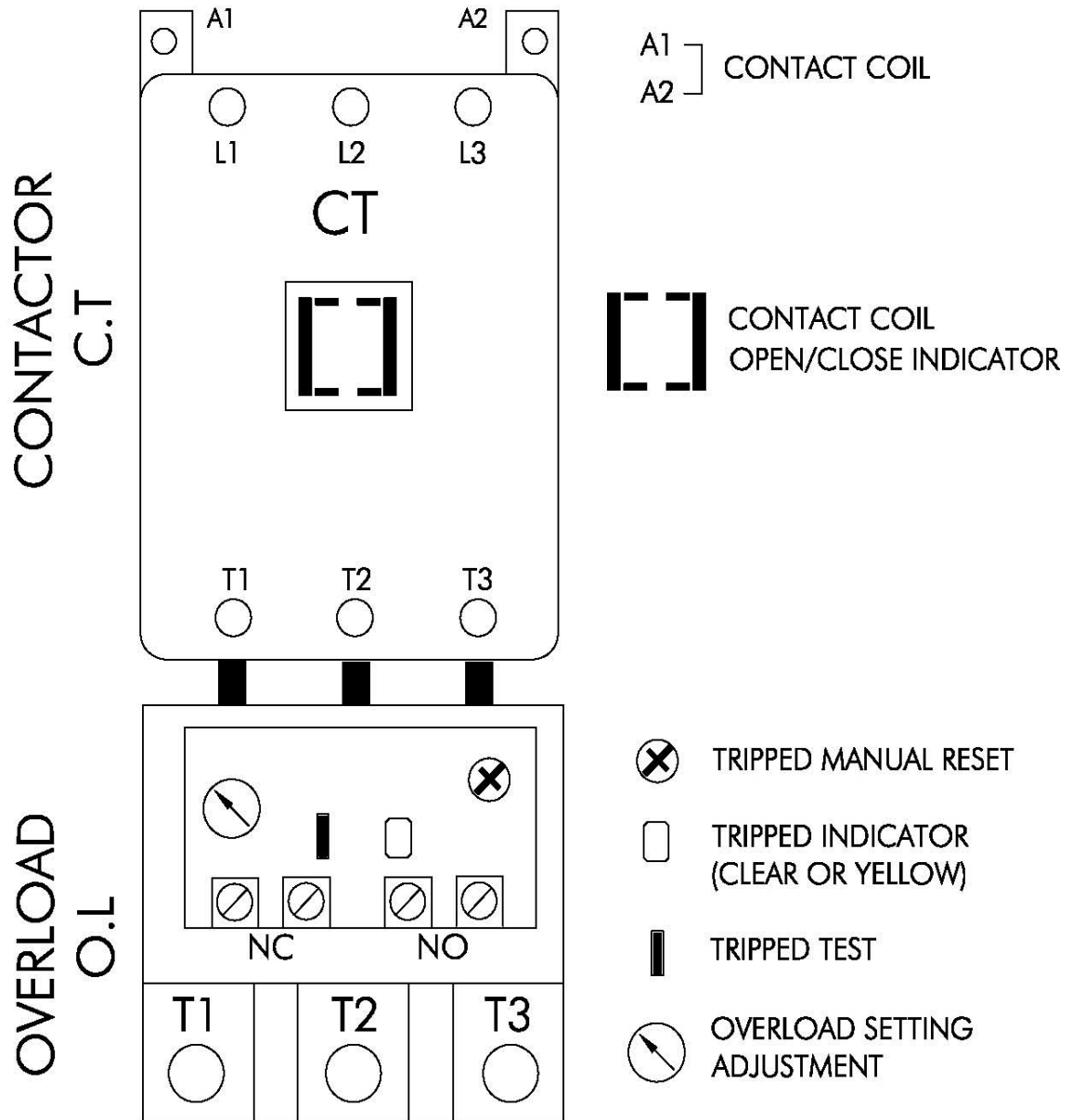



Super Saver Pressure Settings

| | Liquid | Air | Hindrominder Tip |
|-----------|--------|-----|------------------|
| Pre-Soak | 50 | 30 | Red |
| Whitewall | 50 | 40 | Grey |
| Brush | 40 | 30 | Blue |
| Wax | 50 | 30 | Red |

High Pressure pump- 1000 PSI @ 3.5 GPM

#7 Tip

TYPICAL 5 BAY SUPER SAVER ELECTRICAL COMPONENTS PANEL LAYOUT

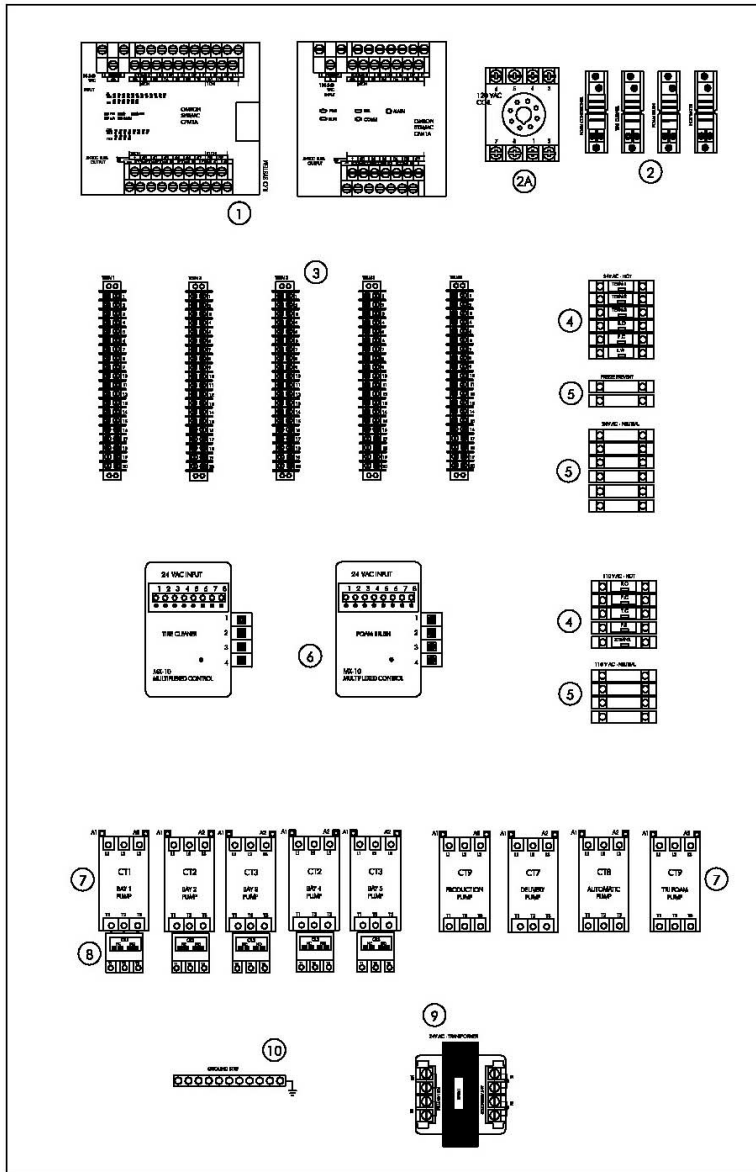

- ① OMRON PLC CONTROL
- ② 24VAC COIL SPDT RELAY (IDEC)
- ②A 120VAC COIL DPDT RELAY (IDEC)
- ③ 20 POSITION TERMINAL STRIP
- ④ FUSABLE TERMINAL BLOCK
- ⑤ TERMINAL BLOCK
- ⑥ IDE MX-10 MULTIPLEX CONTROL
- ⑦ 24VAC COIL CONTACTOR
- ⑧ 15AMP 3Ø OVERLOAD
- ⑨ 15AMP TRANSFORMER 120-24VAC
- ⑩ 20 POSITION GROUNDING STRIP

STANDARD FOAM GENERATOR

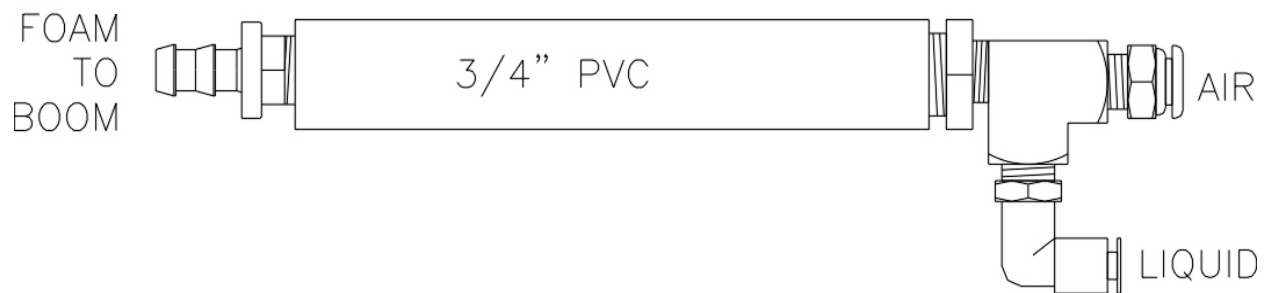

THE FOAM GENERATOR HAS A PLASTIC MESH TO THOROUGHLY MIX THE AIR AND LIQUID TOGETHER. THIS CREATES FOAM.

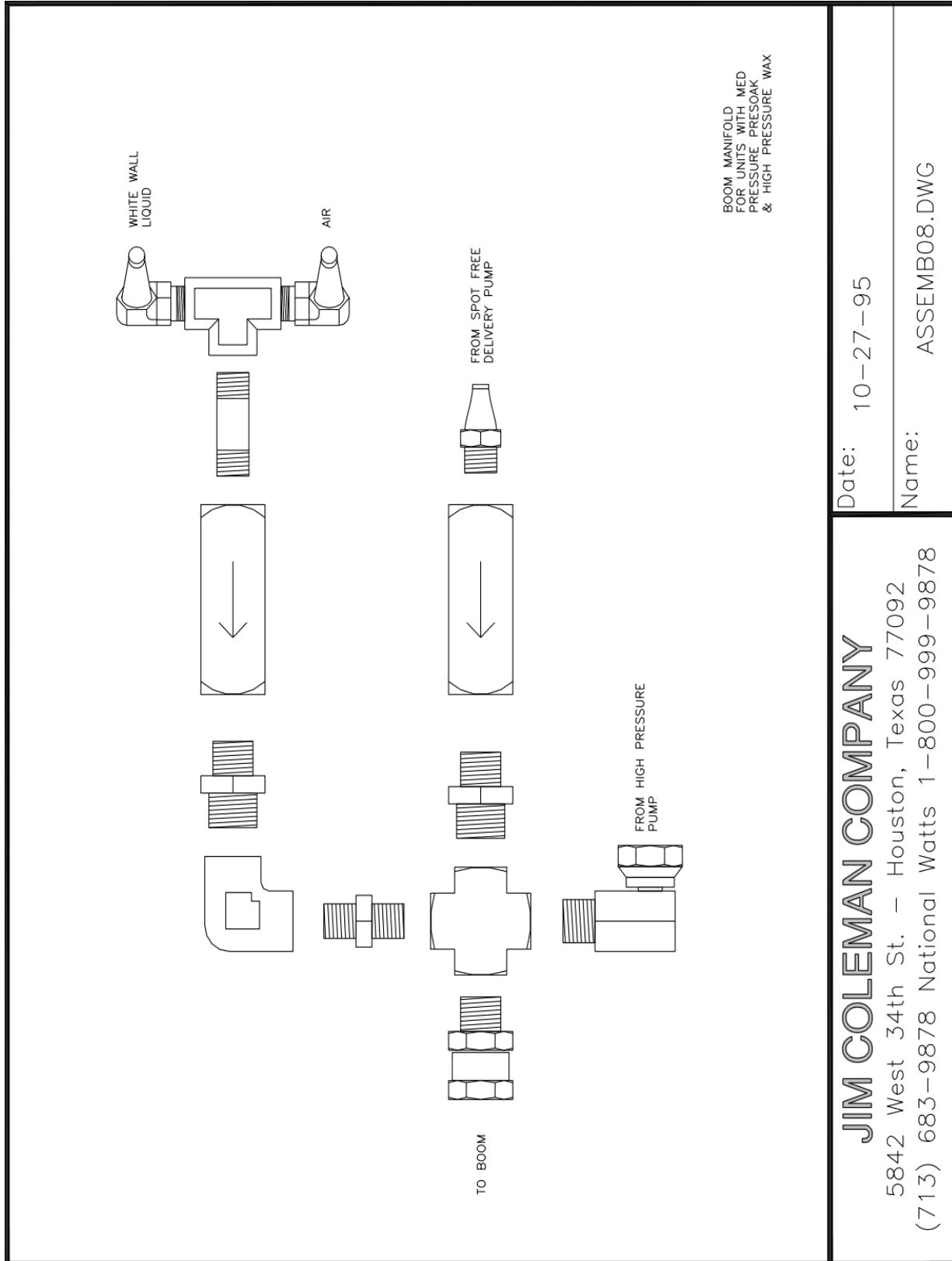

Date: 10-27-95
Name: ASSEMB08.DWG

JIM COLEMAN COMPANY
5842 West 34th St. - Houston, Texas 77092
(713) 683-9878 National Watts 1-800-999-9878

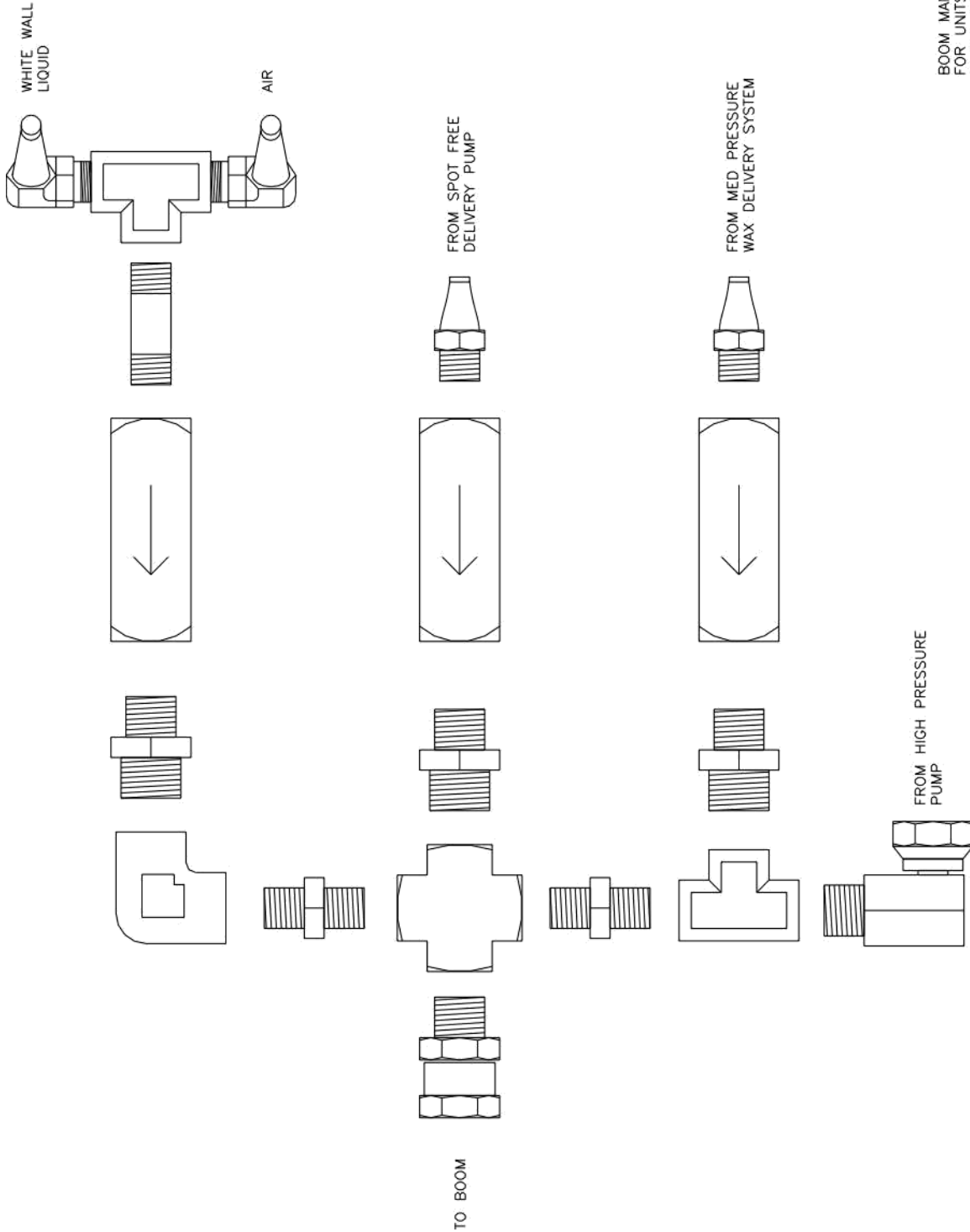

BOOM MANIFOLD
 FOR UNITS WITH MED
 PRESSURE PRESOAK
 & MED PRESSURE WAX

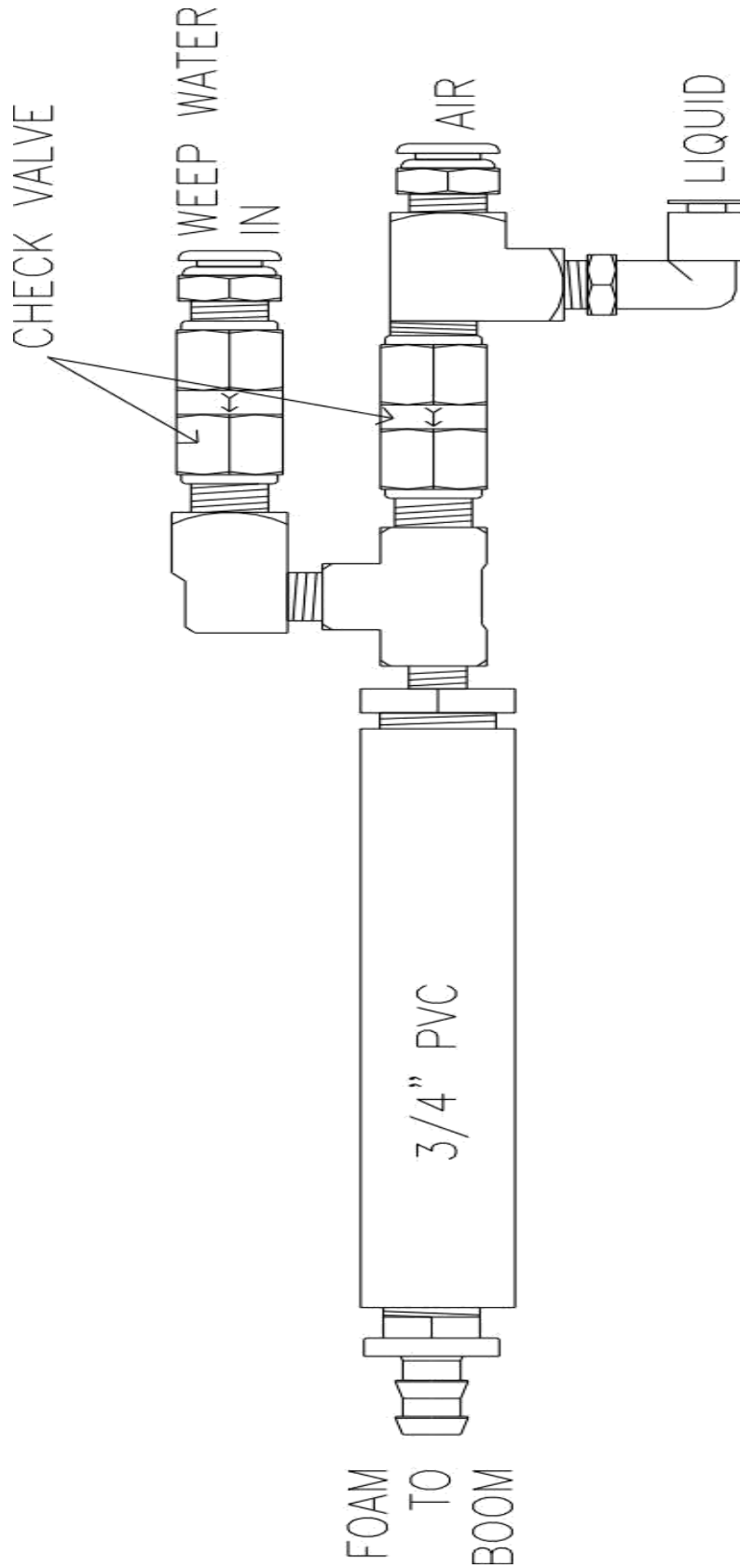

THE FOAM GENERATOR HAS A PLASTIC MESH
 TO THOROUGHLY MIX THE AIR AND LIQUID
 TOGETHER. THIS CREATES FOAM.

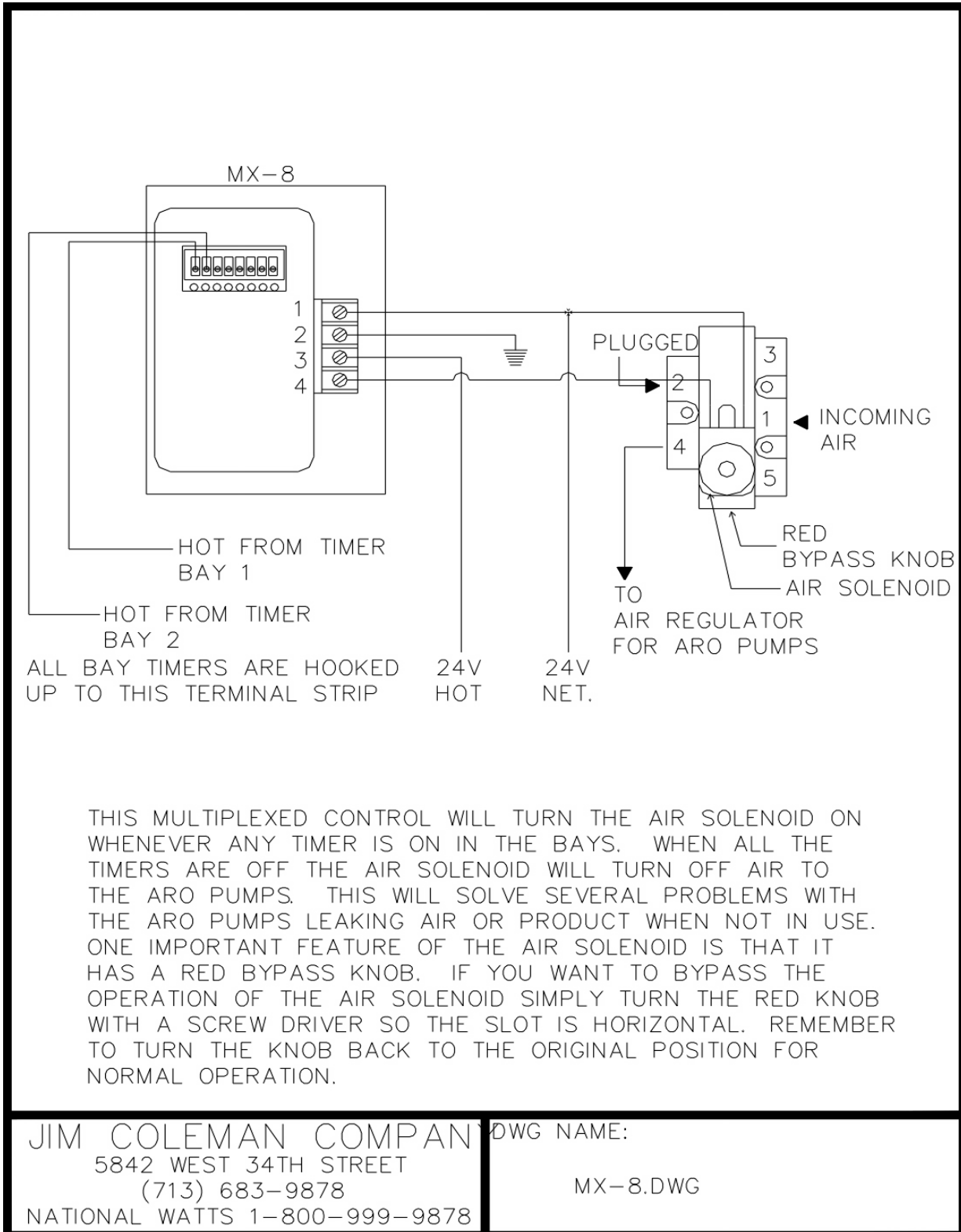



SUPER SAVER MODEL 2500 SPECIFICATIONS

MOTOR: 3 HP 3 PH TEFC - 208-230V

OPTIONAL: 5 HP - 3 PH, 5 HP - 1 PH, or 3HP – 1 PH

PUMP: CAT 5CP2120
5.0 GPM @ 2000 PSI
19 LITERS/MINUTE @ 140 BAR

**ELECTRICAL
REQUIRED:**

20 AMP 3 PH BREAKER 230V/BAY (9.2 Actual Amp Draw for 3 HP)
30 AMP 3 PH BREAKER 230V/BAY (13.5 Actual Amp Draw for 5 HP)
1 CONTROL CIRCUIT - 20 AMP 1 PH BREAKER 110V/BAY (5.0 Actual Amp Draw)

**WATER LINE
REQUIRED:**

1" COLD WATER FEED TO RINSE MANIFOLD
1" HOT WATER FEED TO WATER TANK

**ENGLISH
DIMENSIONS:**

| | |
|------------------|----------------------------|
| ONE - THREE BAY | 11'2.5" L X 25" D X 70" H |
| FOUR - SIX BAY | 12'11.5" L X 25" D X 70" H |
| SEVEN - NINE BAY | 14'8.5" L X 25" D X 70" H |
| TEN – TWELVE BAY | 16'5.5 L X 25" D X 70" H |

**METRIC
DIMENSIONS:**

| | |
|------------------|-------------------------|
| ONE – THREE BAY | 3416mm X 635mm X 1078mm |
| FOUR - SIX BAY | 3950mm X 635mm X 1078mm |
| SEVEN - NINE BAY | 4483mm X 635mm X 1078mm |
| TEN - TWELVE BAY | 5017mm X 635mm X 1078mm |

POWER PACK SPECIFICATIONS

MOTOR: 3 HP 3 PH TEFC - 208-230V

OPTIONAL: 5 HP - 3 PH, 5 HP - 1 PH, or 3HP – 1 PH

PUMP: CAT 5CP2120
5.0 GPM @ 2000 PSI
19 LITERS/MINUTE @ 140 BAR

ELECTRICAL REQUIRED:

20 AMP 3 PH BREAKER 230V/BAY (9.2 Actual Amp Draw for 3 HP)
30 AMP 3 PH BREAKER 230V/BAY (13.5 Actual Amp Draw for 5 HP)

1 CONTROL CIRCUIT -

20 AMP 1 PH BREAKER 110V/BAY (5.0 Actual Amp Draw)

WATER LINE REQUIRED:

1" COLD WATER FEED TO RINSE MANIFOLD
1" HOT WATER FEED TO WATER TANK















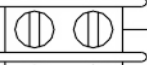

ENGLISH DIMENSIONS:

| | |
|-----------------|-------------------------|
| ONE – THREE BAY | 7'11" L X 25" D X 70" H |
| FOUR - SIX BAY | 9'8" L X 25" D X 70" H |

METRIC DIMENSIONS:

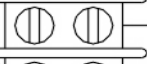
| | |
|-----------------|-------------------------|
| ONE - THREE BAY | 2413mm X 635mm X 1078mm |
| FOUR – SIX BAY | 1664mm X 635mm X 1078mm |

CONTROL PANEL TERMINAL STRIP

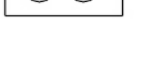
| | | | |
|----|---|------------|---|
| 1 |  | BLK | 24 VOLT HOT |
| 2 |  | WHT | 24 VOLT COMMON |
| 3 |  | BLUE | COIN SWITCH |
| 4 |  | RED | TIMED OUTPUT |
| 5 |  | ORANGE | MOTOR STARTER |
| 6 |  | BROWN | SOAP |
| 7 |  | GREEN | GROUND |
| 8 |  | PURPLE | RINSE |
| 9 |  | YELLOW | TIRE/ENG CLEANER |
| 10 |  | GREY | FOAM BRUSH |
| 11 |  | TAN | PRESOAK |
| 12 |  | PINK | SPOT FREE |
| 13 |  | RED/YELLOW | TOKENS |
| 14 |  | RED/GREEN | WAX |
| 15 |  | RED/BLACK | LOW PRES AIR SOLEN |
| 16 |  | WHT/BLK | AUX 1 (HIGH PRESSURE DEMA SOLENOID) |
| 17 |  | WHT/BLUE | CLEAR COAT |
| 18 |  | WHT/RED | N/A |
| 19 |  | WHT/GREEN | AUX 2 (SOMETIMES LOW PRESSURE AIR SOLENOID) |
| 20 |  | WHT/YELLOW | FOAMING CONDITIONER |

**AUX 1 & AUX 2 IS ONLY USED
ON SELECT & TOUCH**

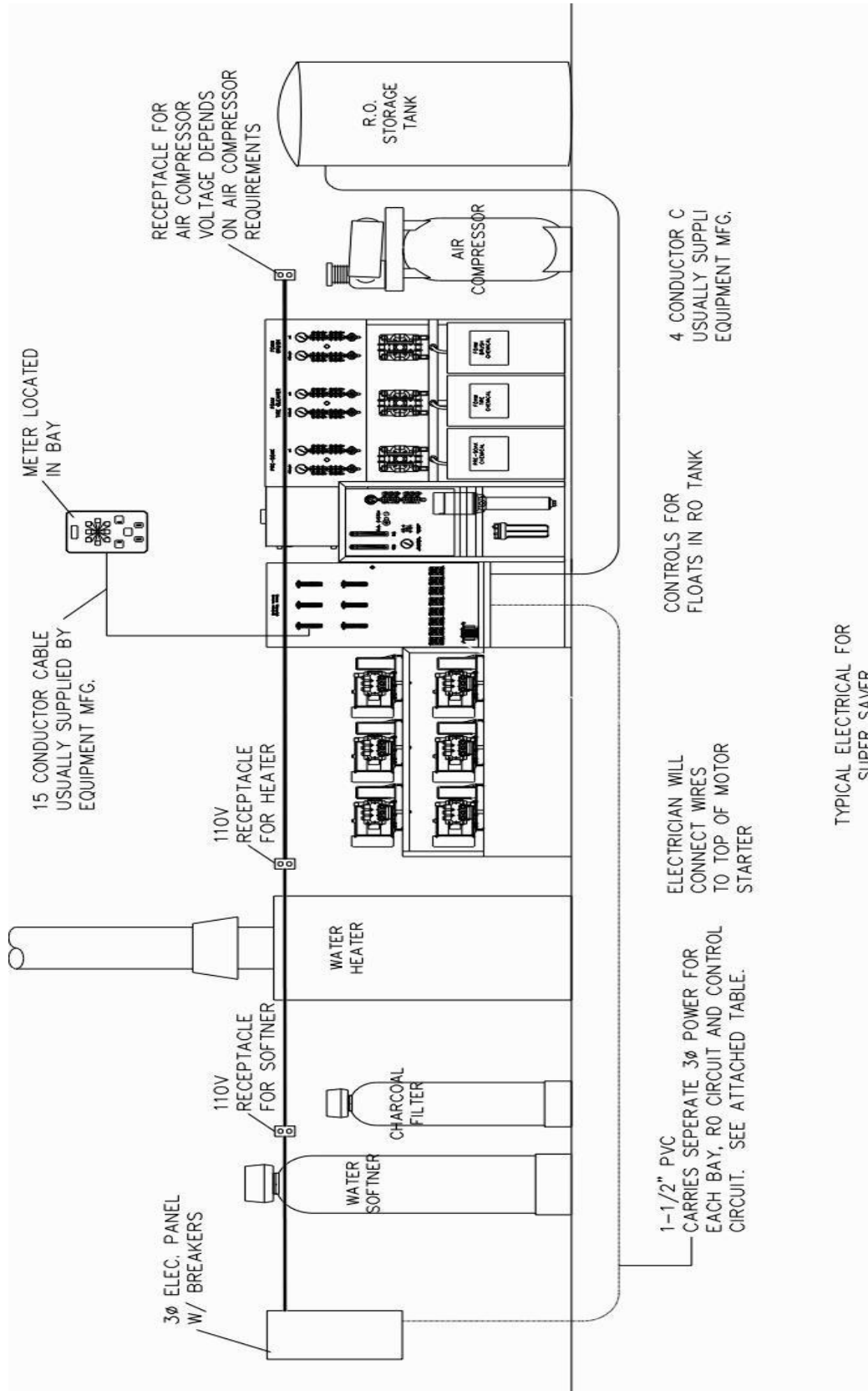

PROVIDE SEPARATE ELECTRICAL CIRCUIT TO EACH MOTOR STARTER FOR EACH BAY

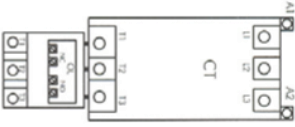

PROVIDE SEPARATE 110V ELECTRICAL CIRCUIT TO TRANSFORMER NOT TO EXCEED 20 AMP OVER CURRENT PROTECTION

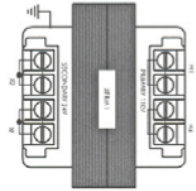

PROVIDE SEPARATE ELECTRICAL CIRCUIT TO MOTOR STARTER FOR SPOT FREE RINSE



| BAY METER | | | | | | |
|-----------|----|------|-----------|--------------|-----------------|--|
| HP | PH | VOLT | WIRE SIZE | BREAKER SIZE | ACTUAL AMP DRAW | |
| 3 | 3 | 240 | 12 | 20 | 9.3 | |
| 5 | 3 | 240 | 10 | 30 | 13.2 | |
| 3 | 3 | 460 | 12 | 15 | 4.8 | |
| 5 | 3 | 460 | 12 | 15 | 6.5 | |
| 3 | 1 | 240 | 10 | 30 | 19.0 | |
| 5 | 1 | 240 | 10 | 40 | 25.0 | |

| SPOT-FREE PRODUCTION MOTOR | | | | | | |
|----------------------------|----|------|-----------|--------------|-----------------|--|
| HP | PH | VOLT | WIRE SIZE | BREAKER SIZE | ACTUAL AMP DRAW | |
| 1/2 | 1 | 240 | 12 | 15 | 3.6 | |
| 3/4 | 1 | 240 | 12 | 15 | 5.4 | |
| 1 | 1 | 240 | 12 | 20 | 9.0 | |
| 1 | 3 | 240 | 12 | 15 | 4.1 | |

| DELIVERY MOTOR | | | | | | |
|----------------|----|------|-----------|--------------|-----------------|--|
| HP | PH | VOLT | WIRE SIZE | BREAKER SIZE | ACTUAL AMP DRAW | |
| 1 | 1 | 240 | 12 | 20 | 9.0 | |
| 1 1/2 | 1 | 240 | 12 | 20 | 10.5 | |
| 3 | 3 | 240 | 12 | 15 | 4.1 | |
| 1 1/2 | 3 | 240 | 12 | 20 | 6.0 | |
| 3 | 3 | 240 | 12 | 20 | 9.3 | |

| TRANSFORMER | | | | | | |
|-------------|----|------|-----------|--------------|-----------------|--|
| HP | PH | VOLT | WIRE SIZE | BREAKER SIZE | ACTUAL AMP DRAW | |
| -0- | 1 | 120 | 12 | 15 | 5.0 | |

| | | | | | | | |
|---|---------------------|--------------|-----------------|---------------------|--------------|--------------------|--------------|
| OWNER: BARRY BRODERSON COLUMBIANA, OKLAHOMA | | DATE: _____ | | DRAWN BY: _____ | | APPROVED BY: _____ | |
| PROJECT: _____ | | | | MOTOR SPECIFICATION | | | |
| TOTAL: _____ | DATE: _____ | ISSUE: _____ | DRAWN BY: _____ | APPROVED BY: _____ | DATE: _____ | ISSUE: _____ | DATE: _____ |
| DESIGNED BY: _____ | EQUIPMENT NO: _____ | DATE: _____ | ISSUE: _____ | DATE: _____ | ISSUE: _____ | DATE: _____ | ISSUE: _____ |



JIM COLEMAN COMPANY
AN OTHANRAHAN COLEMAN COMPANY

FORM E4.0

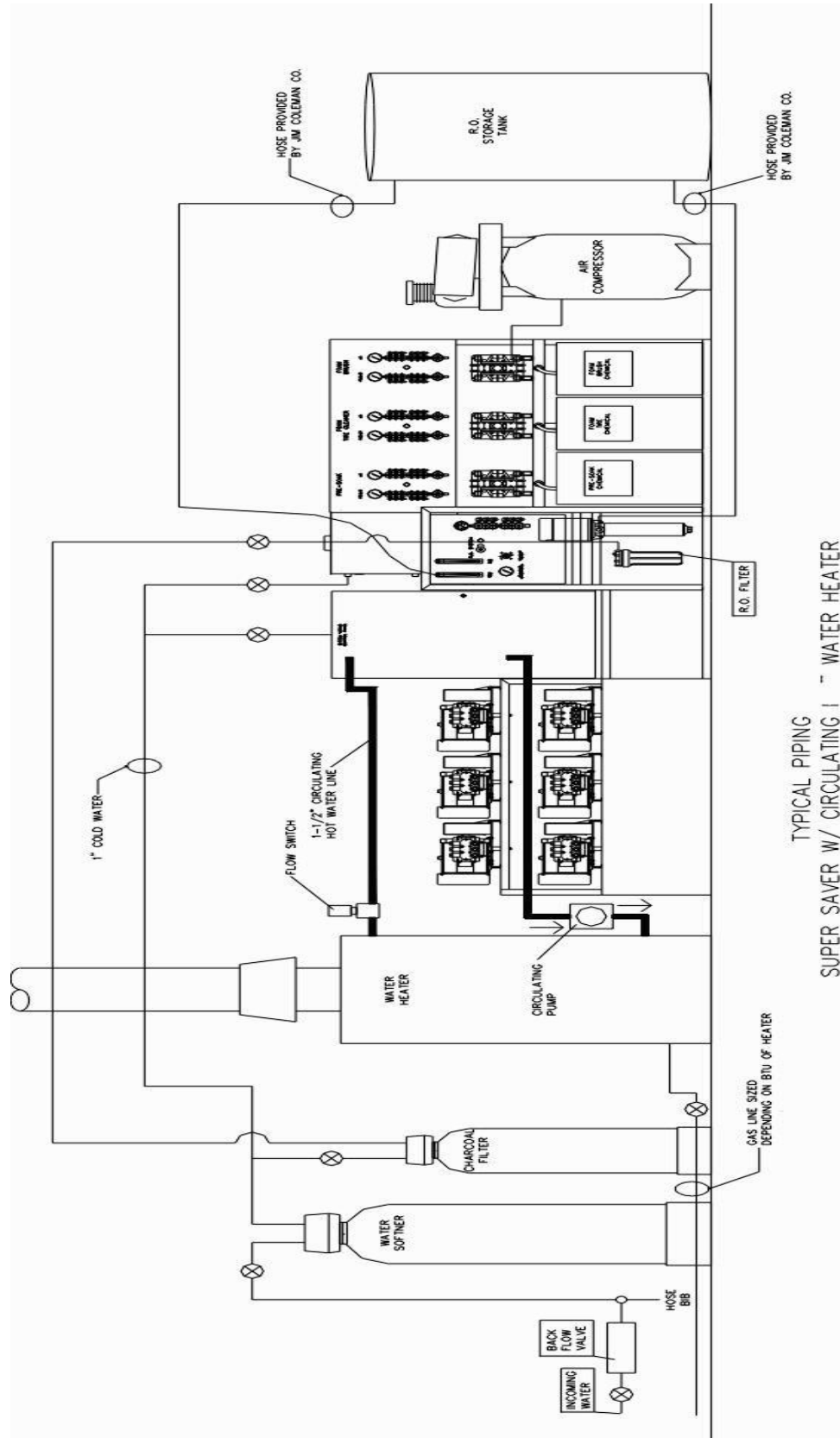

TYPICAL PIPING
SUPER SAVER W/ CIRCULATING HOT WATER HEATER

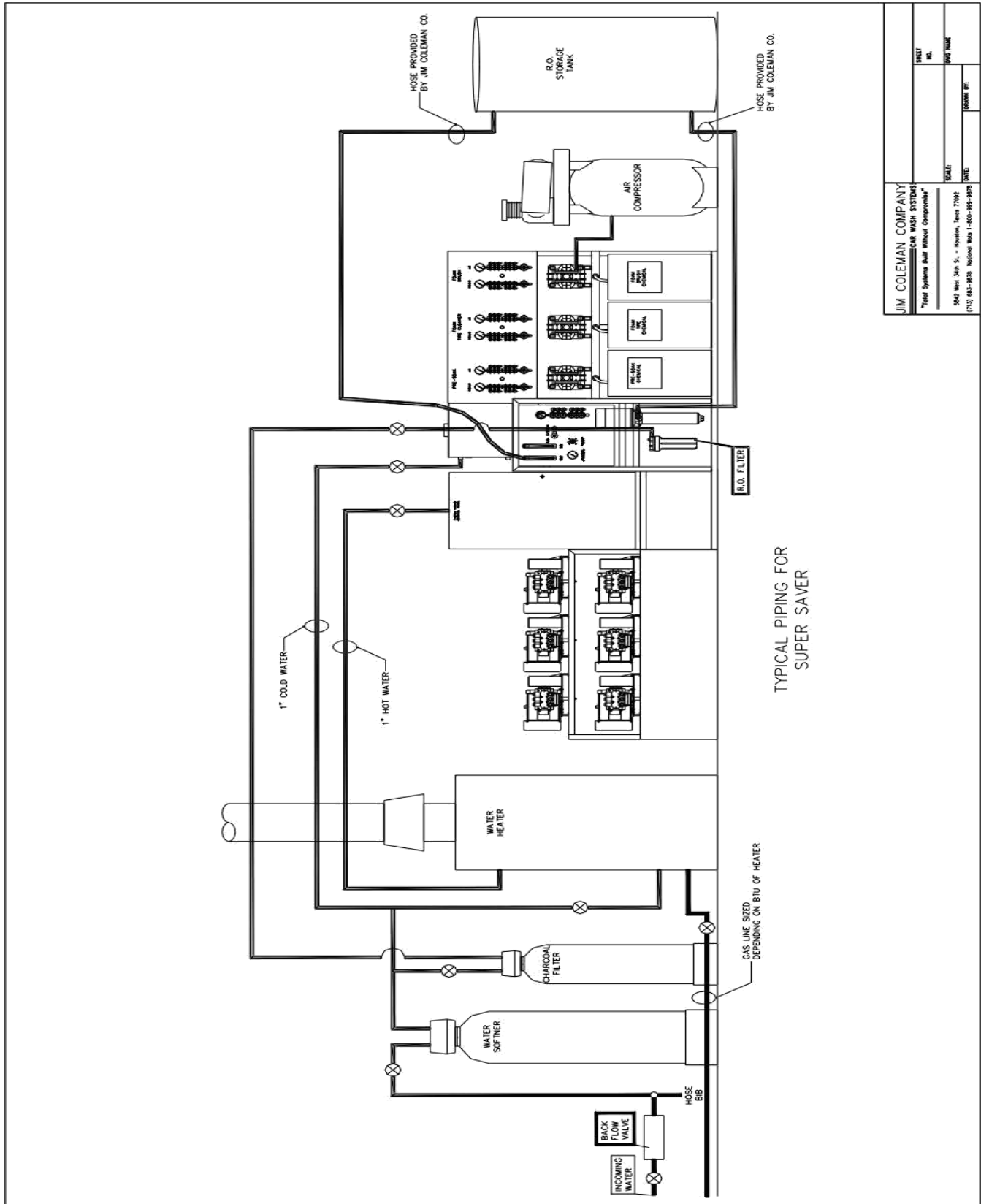

| | | |
|---|-------|--------------|
| JIM COLEMAN COMPANY CAR WASH SYSTEMS "Self Serve Wash Without Compressor" | | SHEET NO. |
| 2642 West 24th St. - Houston, Texas 77058 (713) 883-8855, National Wash 1-800-999-8855 | SCALE | DRAWN BY |
| | | CHECKED BY |
| | | DATE |

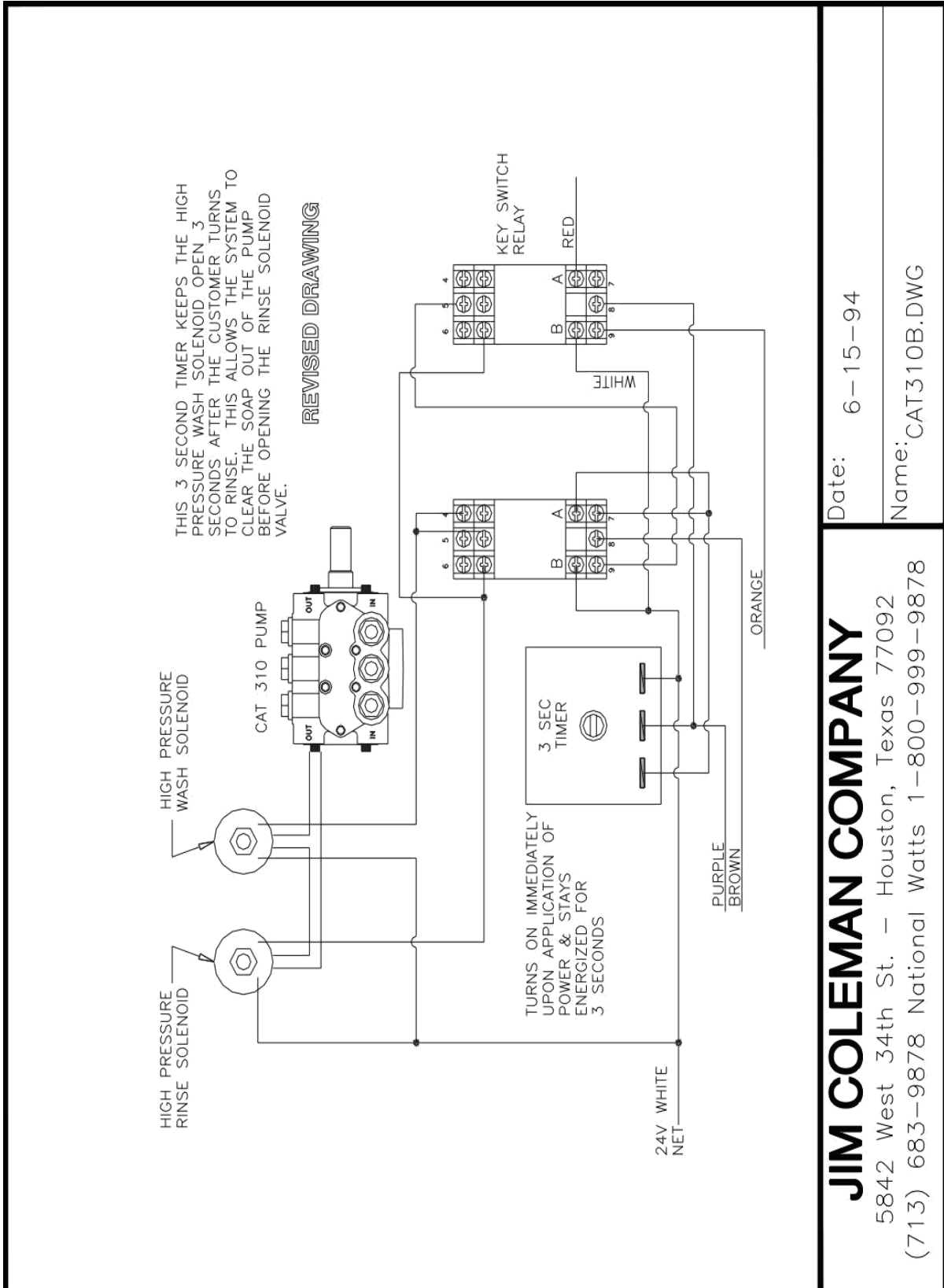

Date: 6-15-94

Name: CAT310B.DWG

JIM COLEMAN COMPANY

5842 West 34th St. - Houston, Texas 77092

(713) 683-9878 National Watts 1-800-999-9878

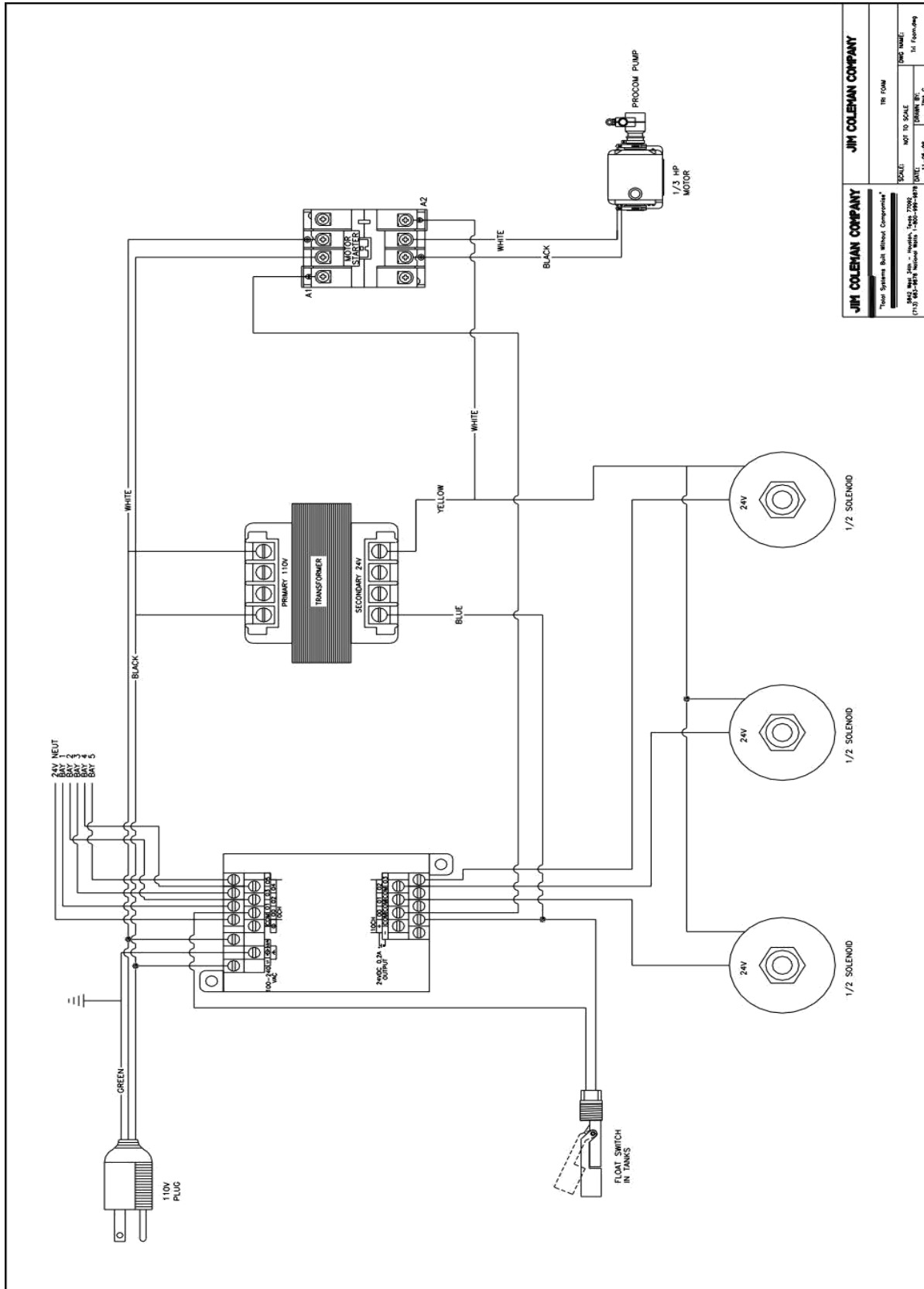

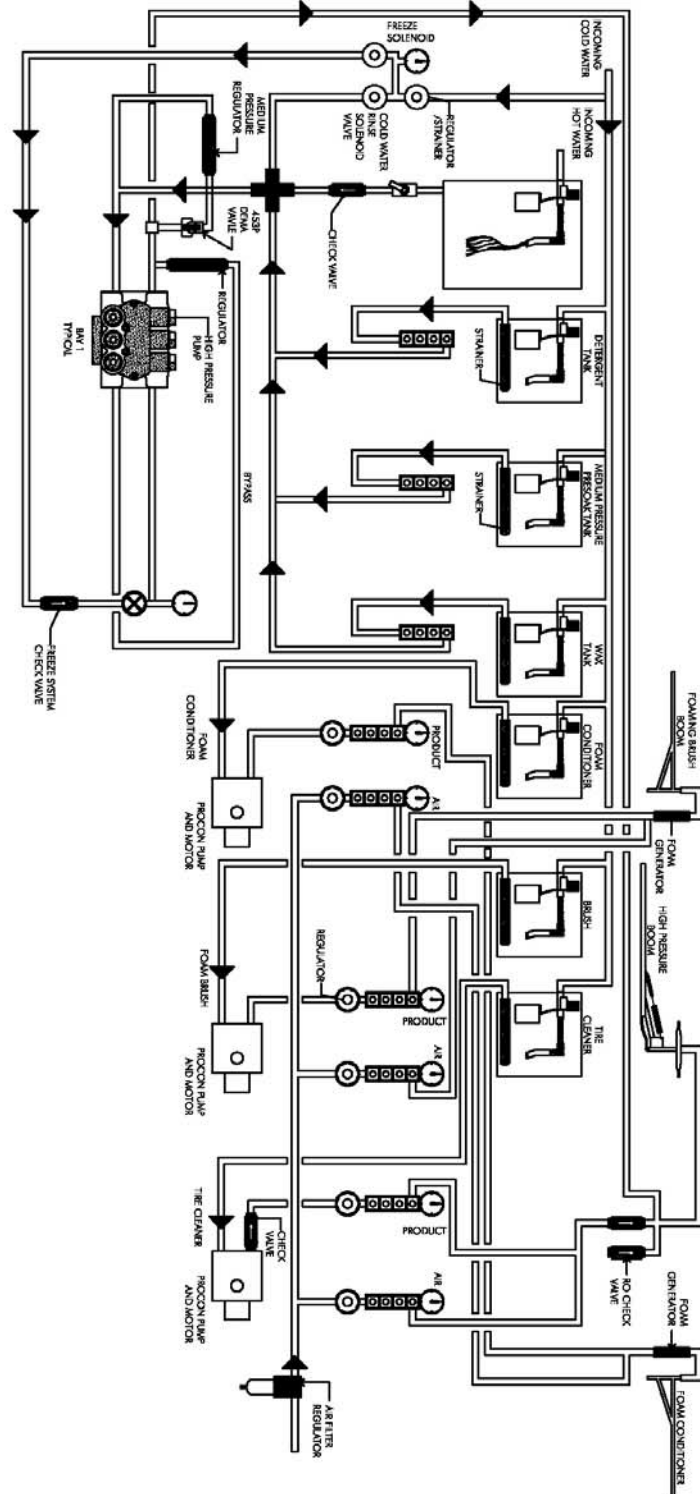

SUPERSAVER FLOW DIAGRAM

TECHNICAL INFORMATION

LAYOUT FOR BAY EQUIPMENT

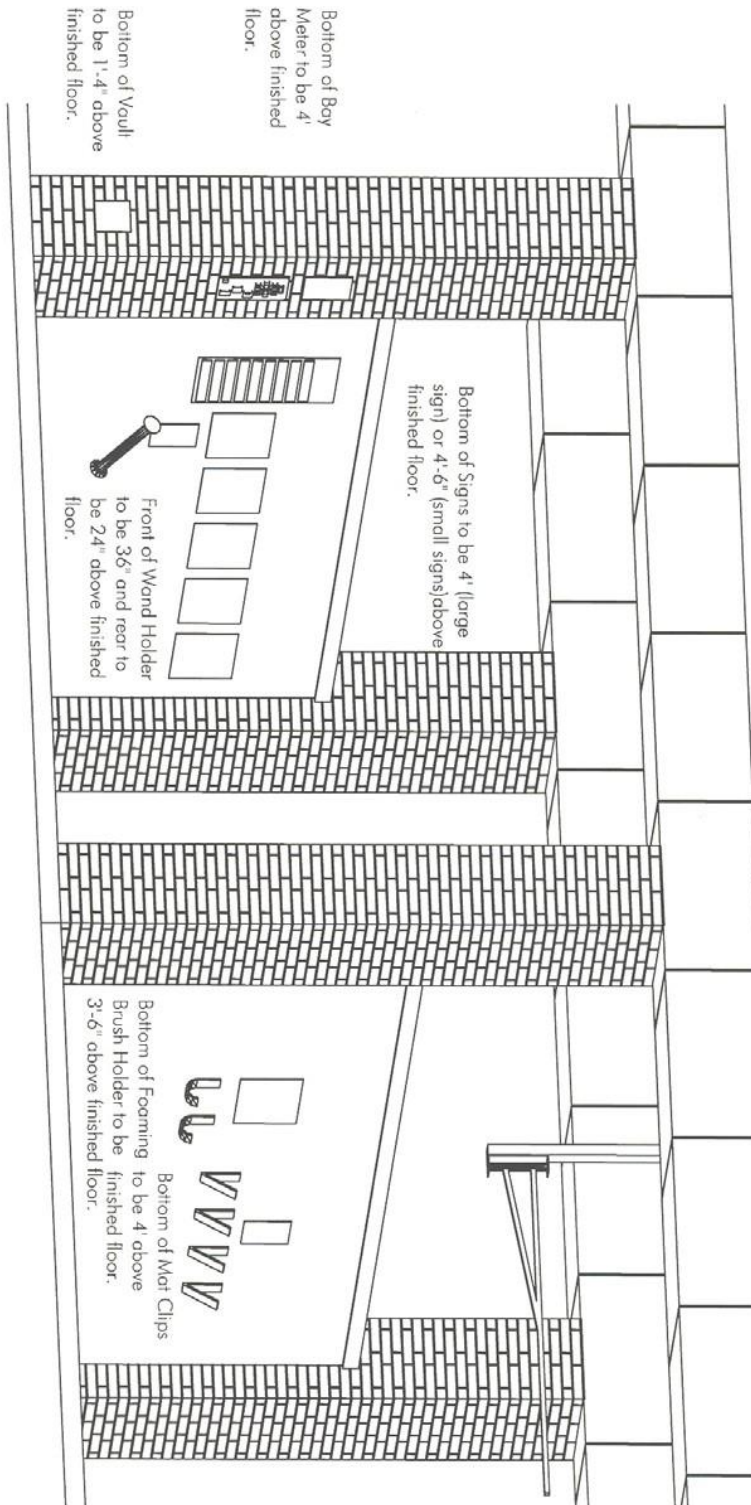

Foam Brush Boom should be mounted 4" below Super Boom and located in center of the bay wall.

For Super Boom mounting instructions see Technical Information sheet T569-3.88

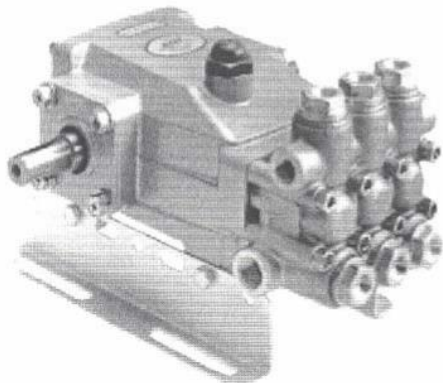
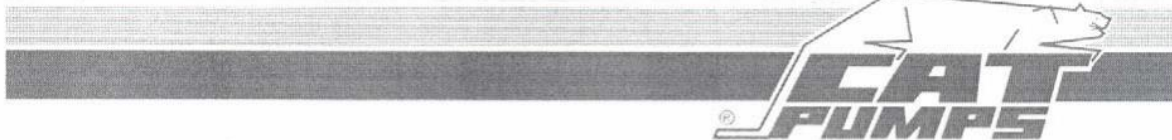

5CP Plunger Pump

Models **5CP2120W**
5CP2140WCS
5CP2150W

FEATURES

Superior Design

- Triplex plunger design gives smoother liquid flow.
- Hi-Pressure Seals are completely lubricated and cooled by the liquids being pumped.
- Inlet and discharge valve assemblies interchange for easier maintenance.
- Lubricated Lo-Pressure Seals provides double protection against external leakage.
- Oil bath crankcase assures optimum lubrication.
- Close tolerance concentricity of the ceramic plunger maximizes seal life.

Quality Materials

- All stainless steel valves are heat treated and seats are roller burnished for a positive seal and extended valve life.
- Forged brass manifolds for strength and corrosion resistance.
- Special blend W770 manifold offers washout and freeze protection for car wash applications.
- Special concentric, high density, polished, graphite impregnated, solid ceramic plungers are abrasion resistant and result in extended seal life.
- Specially formulated, CAT PUMP exclusive, Hi-Pressure Seals offer unmatched performance and seal life.
- Die cast aluminum crankcase provides high strength, minimum weight and precision tolerance control.
- Chrome-moly crankshaft gives unmatched strength and surface hardness.
- Oversized crankshaft bearings with greater loading capacity mean longer bearing life.

Easy Maintenance

- Convenient "press-in" style seal case for ease in servicing.
- Wet-end is easily serviced without entering crankcase, requiring less time and effort.
- Valve assemblies are accessible without disturbing piping, for quick service.
- Preset packings mean no packing gland adjustment is necessary, reducing maintenance costs.

WARNING

All systems require both a primary pressure regulating device (i.e., regulator, unloader) and a secondary pressure safety relief device (i.e., pop-off valve, safety valve). Failure to install such relief devices could result in personal injury or damage to the pump or to system components. CAT PUMPS does not assume any liability or responsibility for the operation of a customer's high pressure system.

SPECIFICATIONS

| | U.S. Measure | Metric Measure |
|-------------------------|--------------|----------------|
| MODEL 5CP2120W | | |
| Flow | 4.0 GPM | (15 L/M) |
| Pressure Range..... | 100-2500 PSI | (7-175 BAR) |
| RPM | 950 RPM | (950 RPM) |
| Bore..... | 0.787" | (20 mm) |
| Stroke..... | 0.709" | (18 mm) |
| Weight..... | 19.14 lbs. | (8.7 kg) |
| MODEL 5CP2140WCS | | |
| Flow | 4.0 GPM | (15 L/M) |
| Pressure Range..... | 100-2500 PSI | (7-175 BAR) |
| RPM | 1725 RPM | (1725 RPM) |
| Bore..... | 0.787" | (20 mm) |
| Stroke..... | 0.394" | (10 mm) |
| Weight..... | 19.14 lbs. | (8.7 kg) |
| MODEL 5CP2150W | | |
| Flow | 5.0 GPM | (19 L/M) |
| Pressure Range..... | 100-2000 PSI | (7-140 BAR) |
| RPM | 1725 RPM | (1725 RPM) |
| Bore..... | 0.787" | (20 mm) |
| Stroke..... | 0.472" | (12 mm) |
| Weight..... | 19.14 lbs. | (8.7 kg) |

COMMON SPECIFICATIONS

| | | |
|--|----------------------|----------------------|
| Inlet Pressure Range (950 RPM) | -5 to 60 PSI | (-0.35 to 4 BAR) |
| Inlet Pressure Range (1725 RPM) ...Flooded to 60 PSI | | (Flooded to 4 BAR) |
| Crankcase Capacity..... | 17 oz. | (0.5 L) |
| Max. Liquid Temperature | 160°F | (71°C) |
| Inlet Ports (2)..... | 1/2" NPTF | (1/2" NPTF) |
| Discharge Ports (2)..... | 3/8" NPTF | (3/8" NPTF) |
| Shaft Diameter..... | 0.787" | (20 mm) |
| Dimensions..... | 10.35 x 10.0 x 5.78" | (263 x 254 x 147 mm) |

HORSEPOWER REQUIREMENTS

| MODEL | FLOW | | PRESSURE | | | | MOTOR PULLEY SIZE | |
|-----------|----------|-----|----------|----------|----------|----------|-------------------|-------------|
| | U.S. GPM | L/M | PSI 1200 | PSI 1500 | PSI 2000 | PSI 2500 | RPM | Pulley O.D. |
| 2120W | 4.0 | 15 | 3.3 | 4.1 | 5.5 | 6.9 | 950 | 4.3 |
| Alternate | 5.0 | 19 | 4.1 | 5.1 | 6.9 | N/A | 1188 | 5.5 |
| 2140WCS | 4.0 | 15 | 3.3 | 4.1 | 5.5 | 6.9 | 1725 | Direct |
| 2150W | 5.0 | 19 | 4.1 | 5.1 | 6.9 | N/A | 1725 | Direct |

| | | | |
|-------------------------------|-------------------|---|-------------------------------|
| DETERMINING THE PUMP R.P.M. | Rated G.P.M. | = | "Desired" G.P.M. |
| DETERMINING THE REQUIRED H.P. | Rated R.P.M. | = | "Desired" R.P.M. |
| DETERMINING MOTOR PULLEY SIZE | GPM x PSI | = | Electric Brake H. P. Required |
| | 1460 | | |
| | Motor Pulley O.D. | = | Pump Pulley O.D. |
| | Pump R.P.M. | | Motor R.P.M. |

See complete Drive Packages (Includes: Pulleys, Belts, Hubs, Key) Tech Bulletin 003
Refer to pump Service Manual for repair procedure and additional technical information.

"Customer confidence is our greatest asset"

PARTS LIST

| ITEM | 5CP2120W | MATL | 5CP2140WCS | MATL | 5CP2150W | MATL | DESCRIPTION | QTY |
|------|----------|-------|------------|-------|----------|-------|---|-----|
| 2 | 30057 | STL | 30057 | STL | 30057 | STL | Key (M6x6x25) | 1 |
| 5 | 96031 | STZP | 96031 | STZP | 96031 | STZP | Screw, Sems HHC (M8x16) | 8 |
| 8 | 46910 | AL | 46910 | AL | 46910 | AL | Cover, Bearing | 2/1 |
| 10 | 14028 | NBR | 14028 | NBR | 14028 | NBR | O-Ring, Bearing Cover - 70D | 2 |
| 11 | 43222 | NBR | 43222 | NBR | 43222 | NBR | Seal, Oil, Crankshaft | 2 |
| 15 | 14480 | STL | 14480 | STL | 14480 | STL | Bearing, Ball | 2 |
| 20 | 48742 | TNM | 48742 | TNM | 48742 | TNM | Rod, Connecting Assy [10/01] | 3 |
| 25 | 46928 | FCM | — | — | 46982 | FCM | Crankshaft, Dual End | 1 |
| | | | 48203 | FCM | — | | Crankshaft, Single End | 1 |
| 30 | — | — | 48224 | AL | — | | Cover, Bearing Blind | 1 |
| 32 | 46798 | | 46798 | | 46798 | | Cap, Oil Filler, Domed | 1 |
| 33 | 14179 | NBR | 14179 | NBR | 14179 | NBR | O-Ring, Oil Filler Cap - 70D | 1 |
| 37 | 92241 | | 92241 | | 92241 | | Gauge, Oil, Bubble w/Gasket - 80D | 1 |
| 38 | 44428 | NBR | 44428 | NBR | 44428 | NBR | Gasket, Flat, Oil Gauge - 80D | 1 |
| 40 | 92519 | STZP | 92519 | STZP | 92519 | STZP | Screw, Sems HHC (M6x16) | 4 |
| 48 | 25625 | STCP | 25625 | STCP | 25625 | STCP | Plug, Drain (1/4"x19BSP) | 1 |
| 49 | 23170 | NBR | 23170 | NBR | 23170 | NBR | O-Ring, Drain Plug - 70D | 1 |
| 50 | 46940 | AL | 46940 | AL | 46940 | AL | Cover, Rear | 1 |
| 51 | 14044 | NBR | 14044 | NBR | 14044 | NBR | O-Ring, Rear Cover | 1 |
| 53 | 48617 | AL | 48617 | AL | 48617 | AL | Crankcase | 1 |
| 64 | 46746 | CM | 46746 | CM | 46746 | CM | Pin, Crosshead | 3 |
| 65 | 48458 | BBNP | 48458 | BBNP | 48458 | BBNP | Rod, Plunger | 3 |
| 70 | 46838 | NBR | 46838 | NBR | 46838 | NBR | Seal, Oil, Crankcase - 70D | 3 |
| 75 | 43328 | S | 43328 | S | 43328 | S | Slinger, Barrier | 3 |
| 88 | 45697 | S | 45697 | S | 45697 | S | Washer, Keyhole (M18) | 3 |
| 90 | 46841 | CC | 46841 | CC | 46841 | CC | Plunger (M20x50) | 3 |
| 98 | 46730 | NBR | 46730 | NBR | 46730 | NBR | Washer, Seal | 3 |
| | 48394 | FPM | 48394 | FPM | 48394 | FPM | Washer, Seal | 3 |
| | 48432 | EPDM | 48432 | EPDM | 48432 | EPDM | Washer, Seal | 3 |
| 99 | 48201 | SS | 48201 | SS | 48201 | SS | Retainer, Plunger w/Stud (M6) | 3 |
| 100 | 46749 | PVDF | 46749 | PVDF | 46749 | PVDF | Retainer, Seal | 3 |
| 106 | 43305 | NBR | 43305 | NBR | 43305 | NBR | Seal, LPS w/S-Spg | 3 |
| | 45153 | FPM | 45153 | FPM | 45153 | FPM | Seal, LPS w/SS-Spg | 3 |
| | 48429 | EPDM | 48429 | EPDM | 48429 | EPDM | Seal, LPS w/SS-Spg | 3 |
| 120 | 46843 | BB | 46843 | BB | 46843 | BB | Case, Seal (Press-in-style) | 3 |
| 121 | 13978 | NBR | 13978 | NBR | 13978 | NBR | O-Ring, Seal Case - 70D | 3 |
| | 14329 | FPM | 14329 | FPM | 14329 | FPM | O-Ring, Seal Case | 3 |
| | 48904 | EPDM | 48904 | EPDM | 48904 | EPDM | O-Ring, Seal Case | 3 |
| 125 | 43307 | SNG | 43307 | SNG | 43307 | SNG | Seal, HPS w/S | 3 |
| | 44936 | FPM | 44936 | FPM | 44936 | FPM | Seal, HPS w/SS | 3 |
| | 46667 | HT | 46667 | HT | 46667 | HT | Seal, HPS w/S | 3 |
| 139 | 22179 | BBCP | 22179 | BBCP | 22179 | BBCP | Plug, Inlet (1/2"NPT) | 1 |
| 162 | 48361 | D | 48361 | D | 48361 | D | Back-up-Ring, Seat | 6 |
| 163 | 43358 | NBR | 43358 | NBR | 43358 | NBR | O-Ring, Seat - 70D | 6 |
| | 44938 | FPM | 44938 | FPM | 44938 | FPM | O-Ring, Seat - 70D | 6 |
| | 48908 | EPDM | 48908 | EPDM | 48908 | EPDM | O-Ring, Seat | 6 |
| 164 | 43725 | S | 43725 | S | 43725 | S | Seat | 6 |
| 166 | 43723 | S | 43723 | S | 43723 | S | Valve | 6 |
| 167 | 43750 | S | 43750 | S | 43750 | S | Spring | 6 |
| 168 | 44565 | PVDF | 44565 | PVDF | 44565 | PVDF | Retainer, Spring | 6 |
| 172 | 17615 | NBR | 17615 | NBR | 17615 | NBR | O-Ring, Valve Plug - 75D | 6 |
| | 15855 | FPM | 15855 | FPM | 15855 | FPM | O-Ring, Valve Plug - 70D | 6 |
| | 48431 | EPDM | 48431 | EPDM | 48431 | EPDM | O-Ring, Valve Plug - 75D | 6 |
| 174 | 43849 | BBCP | 43849 | BBCP | 43849 | BBCP | Plug, Valve | 6 |
| 185 | 48245 | W770 | 48245 | W770 | 48245 | W770 | Manifold, Head - W770 | 1 |
| 188 | 87872 | STZP | 87872 | STZP | 87872 | STZP | Screw, HSH (M8x70) | 8 |
| 196 | 22187 | BBCP | 22187 | BBCP | 22187 | BBCP | Plug, Discharge (3/8"NPT) | 1 |
| 250 | 118672 | STCP | 118672 | STCP | 118672 | STCP | Protector, Shaft | 1 |
| 255 | 30243 | STZP | 30243 | STZP | 30243 | STZP | Mount, Direct | 1 |
| 260 | 30611 | STZP | 30611 | STZP | 30611 | STZP | Assembly, Angle Rail - B (Incls: 28499, 30900, 30910, 30920) (Belt Drive Only) | 1 |
| 265 | 30637 | STZP | 30637 | STZP | 30637 | STZP | Mount, Angle Assy-Retro Fit | 1 |
| | 30659 | | 30659 | | 30659 | | Kit, Complete Mounting (Incls: 30611, 30633, 118672) (Belt Drive Only) | 1 |
| 275 | 30944 | STL | 30944 | STL | 30944 | STL | Hub & Key Assy (M20 w/M6 Keyway) [See Drive Packages, Tech Bulletin 003] | 1 |
| 283 | 34334 | | 34334 | | 34334 | | Kit, Oil Drain | 1 |
| 298 | 34970 | STZP | 34970 | STZP | 34970 | STZP | Clutch, Assy, Single Groove, 20mm, 12VDC | 1 |
| 299 | 34980 | STZP | 34980 | STZP | 34980 | STZP | Clutch, Assy, Dual Groove, 20mm, 12VDC | 1 |
| 300 | 816650 | W770 | 816650 | W770 | 816650 | W770 | Head, Complete | 1 |
| | 33628 | NBR | 33628 | NBR | 33628 | NBR | Kit, Seal (Incls: 98, 106, 121, 125) | 1 |
| | 31628 | FPM | 31628 | FPM | 31628 | FPM | Kit, Seal (Incls: 98, 106, 121, 125) | 1 |
| | 31648 | EPDM* | 31648 | EPDM* | 31648 | EPDM* | Kit, Seal (Incls: 98, 106, 121, 125) | 1 |
| | 31638 | HT | 31638 | HT | 31638 | HT | Kit, Seal (Incls: 98, 106, 121, 125) | 1 |

EXPLODED VIEW

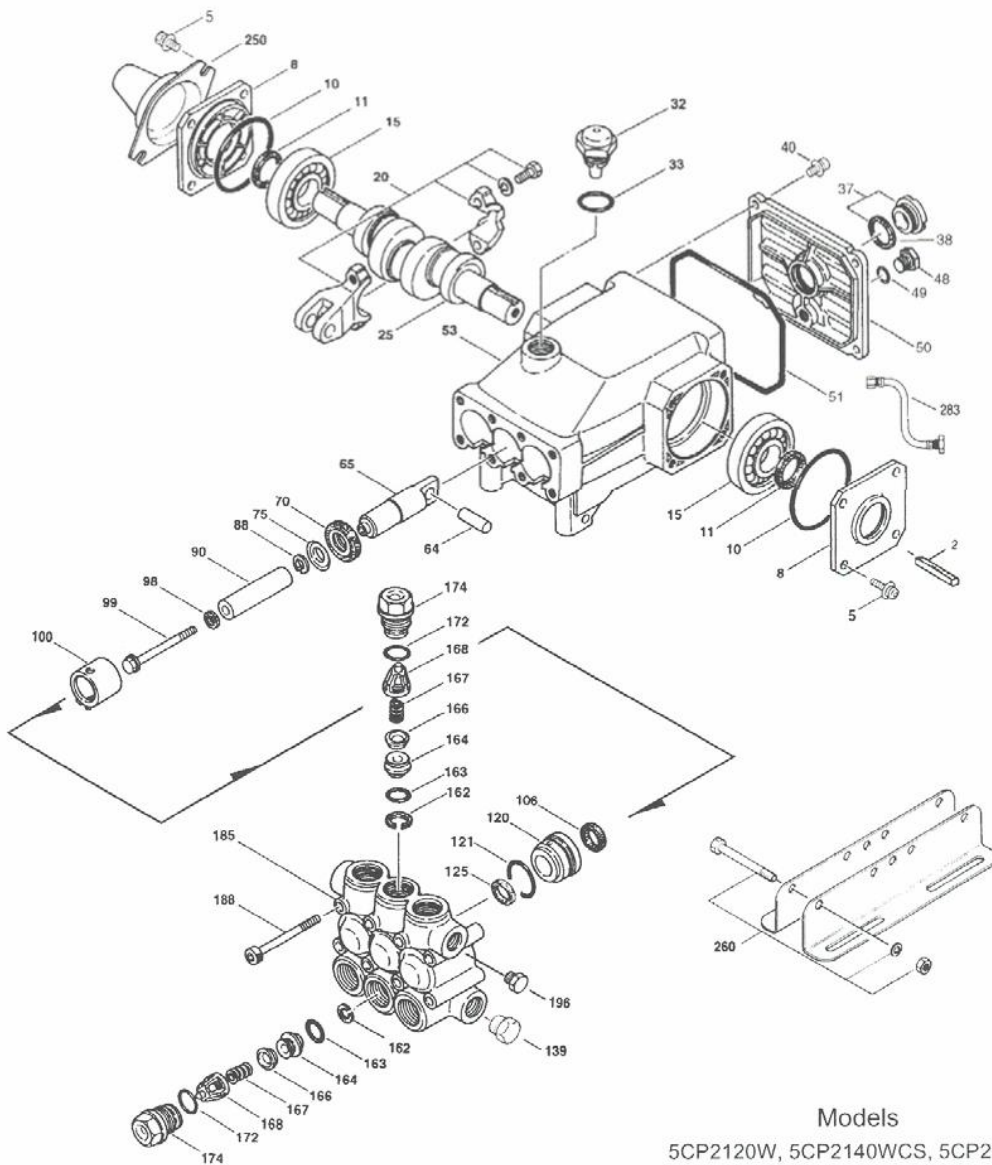

Models

5CP2120W, 5CP2140WCS, 5CP2150W
March 2002

| | 5CP2120W | MATL | 5CP2140WCS | MATL | 5CP2150W | MATL | | |
|-----|----------|------|---------------|------|---------------|------|---|-----|
| 310 | 30821 | NBR | 30821 | NBR | 30821 | NBR | Kit, Valve (Incls: 162,163,164,166,167,168,172) | 2 |
| | 31821 | FPM | 31821 | FPM | 31821 | FPM | Kit, Valve (Incls: 162,163,164,166,167,168,172) | 2 |
| | ♦ 31162 | EPDM | ♦ 31162 | EPDM | ♦ 31162 | EPDM | Kit, Valve (Incls: 162,163,164,166,167,168,172) | 2 |
| 350 | 30696 | STZP | 30696 | STZP | 30696 | STZP | Plier, Reverse | 1 |
| 400 | 7655 | BB | 7655 | BB | 7655 | BB | Modular Unloader (See Individual Data Sheet) | 1 |
| ● | — | — | 8026ES-8042ES | — | 8026ES-8042ES | — | BD Motors (See Individual Data Sheet) | 1 ● |
| — | 6107 | — | 6107 | — | 6107 | — | Oil, Bottle (21 oz) ISO 68 Multi-viscosity Hydraulic (Fill to specified crankcase capacity prior to start-up) | 1 |

● Industrial discount. Bold print part numbers are unique to a particular pump model. Italics are optional items.

♦ Silicone oil/grease required. *Review material codes for individual items (HT generally may be used as alternate).

[] Date of latest production change. See Tech Bulletins 002, 003, 024, 036, 043, 053, 060, 061, 064, 073, 074, 077, 078 and 083 for additional information.
W770 effective with 97 production Add 3 for the Hi-Temp model.

MATERIAL CODES (Not Part of Part Number): AL=Aluminum BB=Brass BBNP=Brass/Nickel Plated CC=Ceramic CM=Chrome-moly D=Delrin*

FBB=Forged Brass FCM=Forged Chrome-moly FPM=Fluorocarbon (Viton™) HS=High Strength HT=Hi-Temp (EPDM Alternative)

NBR=Medium Nitrile (Buna-N) PVDF=Fluoroplastic (High Strength) S=304SS SNG=Special Blend (Buna) STL=Steel

W770=Special Alloy STCP=Steel/Chrome Plated STZP=Steel/Zinc Plated TNM=Special High Strength

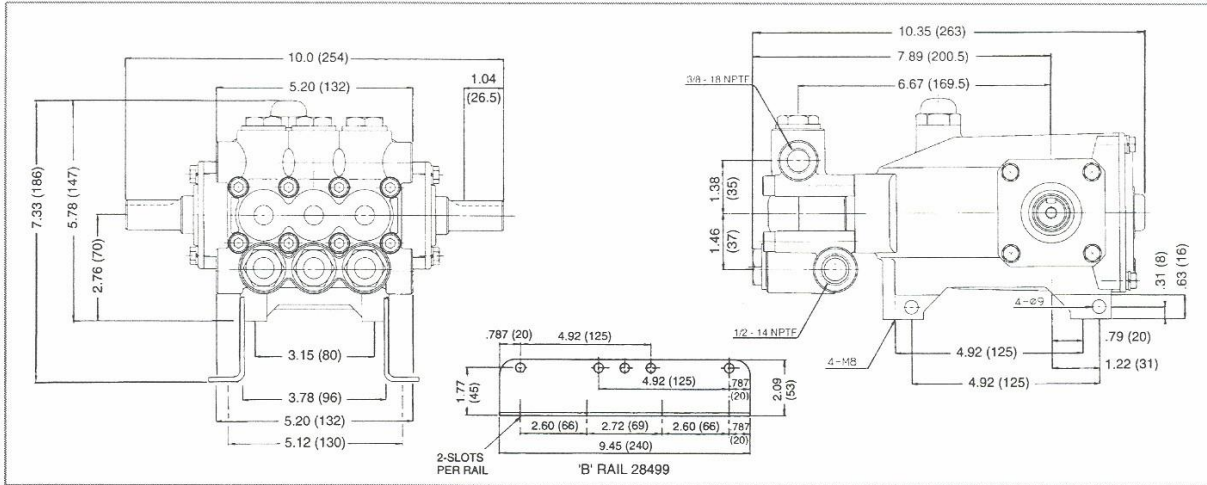

Models 5CP2120W, 5CP2140WCS, 5CP2150W

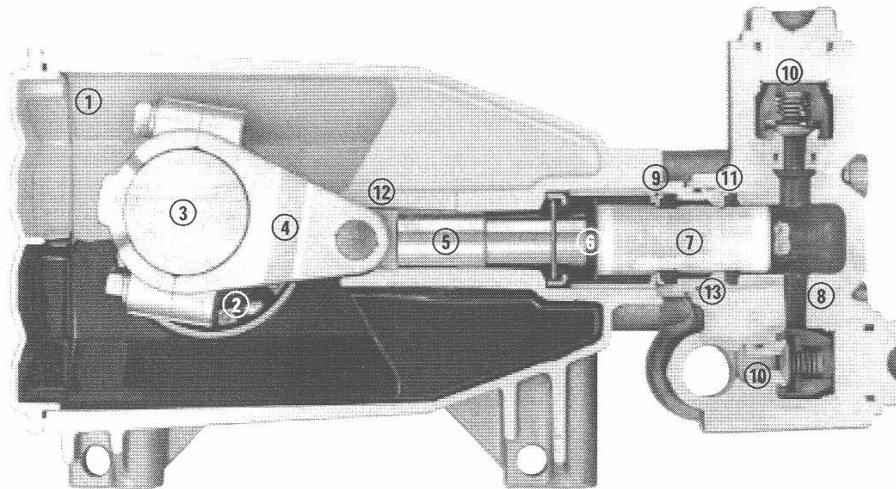

- 1 Die cast aluminum **crankcase** means high strength, lightweight, and excellent tolerance control.
- 2 Oversized crankshaft **bearings** provide extended bearing life and pump performance.
- 3 Chrome-moly **crankshaft** provides unmatched strength and surface hardness for long life.
- 4 Matched high strength **connecting rods** noted for strength and superior bearing quality.
- 5 The **plunger rods** with hardened surfaces offer wear resistance and Zamak cross-heads for high load capacity.
- 6 The stainless steel **slinger** provides back-up protection for the crankcase seal, keeping pumped liquids out of the crankcase.
- 7 Special concentric, high density, polished, graphite impregnated, solid ceramic **plungers** are abrasion resistant and result in extended seal life.
- 8 **Manifolds** are a high tensile strength forged brass for long term, continuous duty.
- 9 100% wet **seal** design adds to service life by allowing pumped liquids to cool and lubricate on both sides.
- 10 Stainless steel **valves, seats and springs** provide corrosion-resistance, positive seating and long life.
- 11 Specially formulated, CAT PUMP exclusive, **Hi-Pressure Seals** offer unmatched performance and seal life.
- 12 **Crossheads** are 360° supported for uncompromising alignment.
- 13 Press-in style **seal case** offers alignment and support for seals and "no tools" servicing.

Products described hereon are covered by one or more of the following U.S. patents 3558244, 3652188, 3809508, 3920356, 3930756 and 5035580

World Headquarters
CAT PUMPS
1681 - 94th Lane N.E. Minneapolis, MN 55449-4324
Phone (763) 780-5440 — FAX (763) 780-2958
e-mail: sales@catpumps.com
www.catpumps.com

International Inquiries
FAX (763) 785-4329
e-mail: intlsales@catpumps.com



"The World's Most Dependable Pumps"

CAT PUMPS (U.K.) LTD.
1 Fleet Business Park, Sandy Lane, Church Crookham, Fleet
Hampshire GU52 8BF, England
Phone Fleet 44 1252-622031 — Fax 44 1252-626655
e-mail: sales@catpumps.co.uk

N.V. CAT PUMPS INTERNATIONAL S.A.
Heiveldekens 6A, 2550 Kontich, Belgium
Phone 32-3-450.71.50 — Fax 32-3-450.71.51
e-mail: cpi@catpumps.be www.catpumps.be

CAT PUMPS DEUTSCHLAND GmbH
Buchwiese 2, D-65510 Idstein, Germany
Phone 49 6126-9303 0 — Fax 49 6126-9303 33
e-mail: catpumps@t-online.de www.catpumps.de

HydroMinder Water Valves Models 502, 503, 570 & 571

PACKAGE CONTAINS:

- | | |
|---|------------------------------|
| 1. Water valve assembly | 3. Float with chain |
| 2. Bracket for mounting (Models 502 and 570 only) | 4. Product information sheet |

THANK YOU FOR YOUR INTEREST IN OUR PRODUCTS

Hydro Systems manufactures quality chemical proportioners. Please use this equipment carefully and observe all warnings and cautions.

*****NOTE*****

| | |
|---------------|---|
| WEAR | protective clothing and eyewear when dispensing chemicals or other materials. |
| ALWAYS | observe safety and handling instructions of the chemical manufacturers. |
| ALWAYS | direct discharge away from you or other persons or into approved containers. |
| ALWAYS | dispense cleaners and chemicals in accordance with manufacturer's instructions. Exercise CAUTION |
| CLEAN | equipment after each use in accordance with instruction sheet. |
| WEAR | equipment after each use to maintain proper operation. |
| ALWAYS | protective clothing and eyewear when working in the vicinity of all chemicals, filling or emptying equipment or changing metering tips. |
| ATTACH | re-assemble equipment according to instruction procedures. Be sure all components are firmly screwed or latched into position. |

only to tap water outlets (85 PSI maximum)

INSTALLATION:

- Mount the unit in a level position on the side of a reservoir. If unit is supplied with a bracket, it may be repositioned or removed as necessary. (Retrofit mounting bracket for model 503: Part #5030-K. Retrofit bracket for model 571: Part #106.)
- Adjust chain length to position float at the desired highest level of water. NOTE: The high volume HydroMinder Water Valves, models 570 and 571, are designed to shut off slowly to help reduce water hammer. Be sure to take this into account when setting the high water level to prevent inadvertent tank overflow. Position the float so that the water discharge does not cause turbulence around the float. It may be necessary to baffle the float from the discharge, or to connect a hose to the HydroMinder discharge fitting so that water is discharged under the water level in the tank.
- For models 502 and 503, install minimum ½-inch water inlet between unit and water supply. Models 570 and 571 should be hard plumbed with minimum 1-inch pipe. Minimum 15 PSID pressure is required for proper operation of the water valves. See flow chart for further information. Larger water lines may be used. They should be plumbed directly into the black valve.

| Approx. Flow Rates for Models 502 and 503 (GPM) | | | |
|---|--------|--------|------------------|
| PSID | Inlet: | ½ " ID | ¾ " ID or larger |
| 30 | | 5.8 | 6.0 |
| 40 | | 6.8 | 9.4 |
| 50 | | 7.7 | |
| 65 | | 8.7 | |

| Approx. Flow Rates for Models 570 and 571 (GPM) | | |
|---|--|-----------------|
| PSID | Inlet: | 1" ID or larger |
| 10 | | 13.0 |
| 20 | | 25.8 |
| 35 | | 44.0 |
| 40+ | Subject to building water system constraints | |

OPERATION:

Turn water source to valve on. If using Model 502, open water supply inlet ball valve. When the solution in the reservoir reaches the level set by the float, the magnetic valve on the HydroMinder will close. This will stop the water flow. When withdrawal from the reservoir causes the level to drop more than 1½ inches, the valve will open and the reservoir will be refilled to the previous level. This cycle will be repeated automatically as long as the water supply is on. The shut-off valve on the 502 and any water source control valves should be **fully closed** when reservoir is drained or when the unit is not in use.

TROUBLESHOOTING:

| PROBLEM | CAUSE | SOLUTION |
|--------------------------------|---|---|
| 1. No discharge | a. No water b. Defective magnetic valve assembly c. Excessive water pressure | a. Open water inlet valve (applies only to 502) b. Replace assembly c. Install regulator if pressure exceeds 85 PSI |
| 2. Failure of unit to turn off | a. Valve parts dirty or defective b. Magnet spring too short c. Clogged valve orifice d. Water pressure too high e. Diaphragm stretched | a. Clean or replace* b. Replace spring c. Clean or replace d. Install regulator if pressure exceeds 85 PSI e. Replace |

* Hard water may cause build-up of mineral deposits in water valve. Remove deposits by soaking the valve parts in a deliming solution.

HydroMinder Water Valve Models 502 & 503: Parts Diagram and List

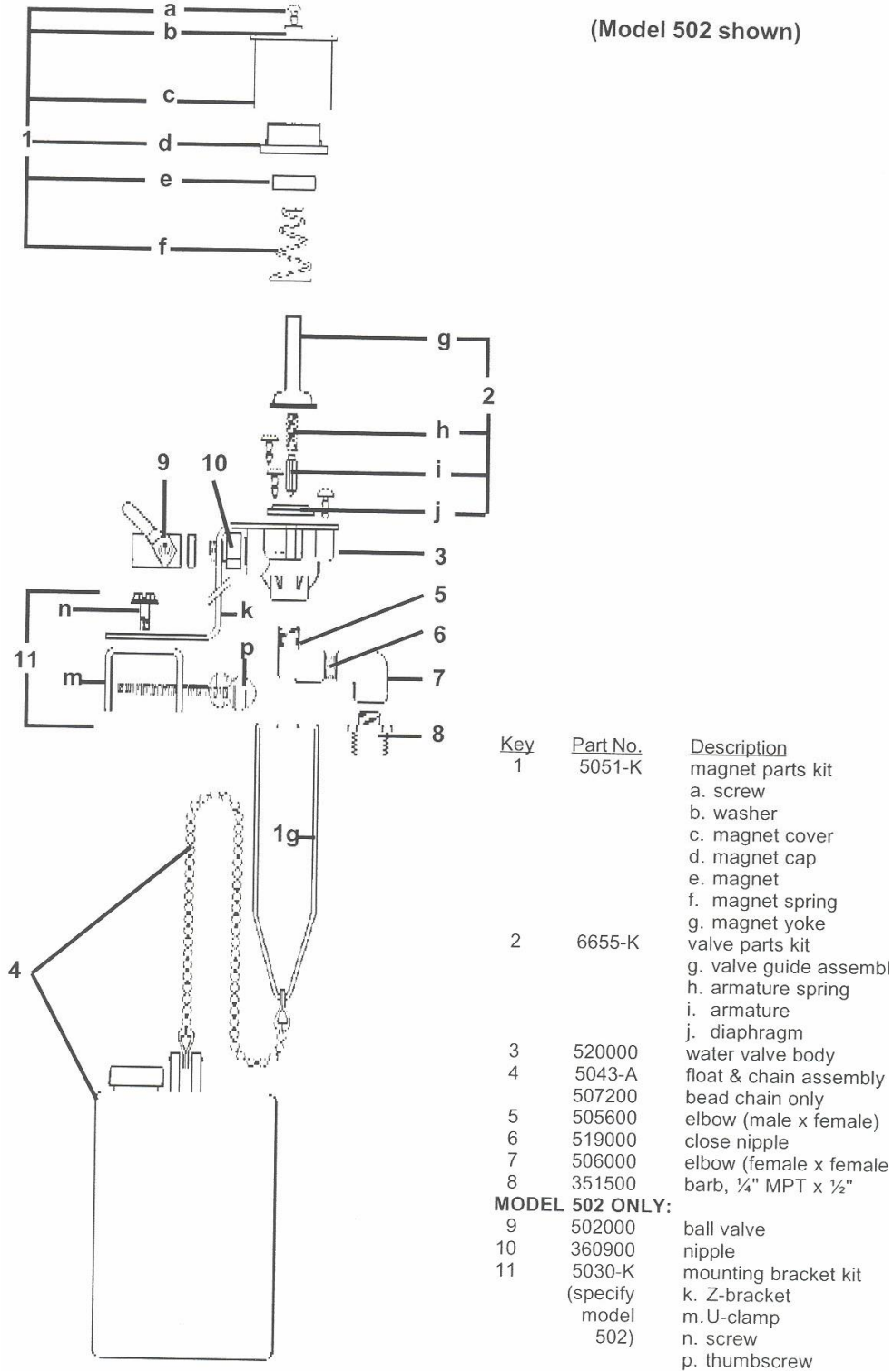

HydroMinder High Volume Water Valve Models 570 & 571: Parts Diagram and List

Key Part No. Description

- 1 560170 magnet cap
- 2 505102 magnet
- 3 560160 conical spring
- 4 560500 actuation kit (includes bonnet, armature & O-ring)
- 5 560100 valve
- a 560800 diaphragm kit (includes spring and screws)
- 6 560180 bushing (3/4 x 1)
- 7 560230 nipple (3/4 x 4 PVC)
- 8 560210 elbow (3/4 PVC)
- 9 419337 3/4" hose barb
- 10 570001 discharge tube 3/4" x 1'
- a 372900 hose clamp
- 11 570100 bracket assembly
- 12 560130 magnet yoke
- 13 5043-A float & chain assembly

(Model 570 shown)

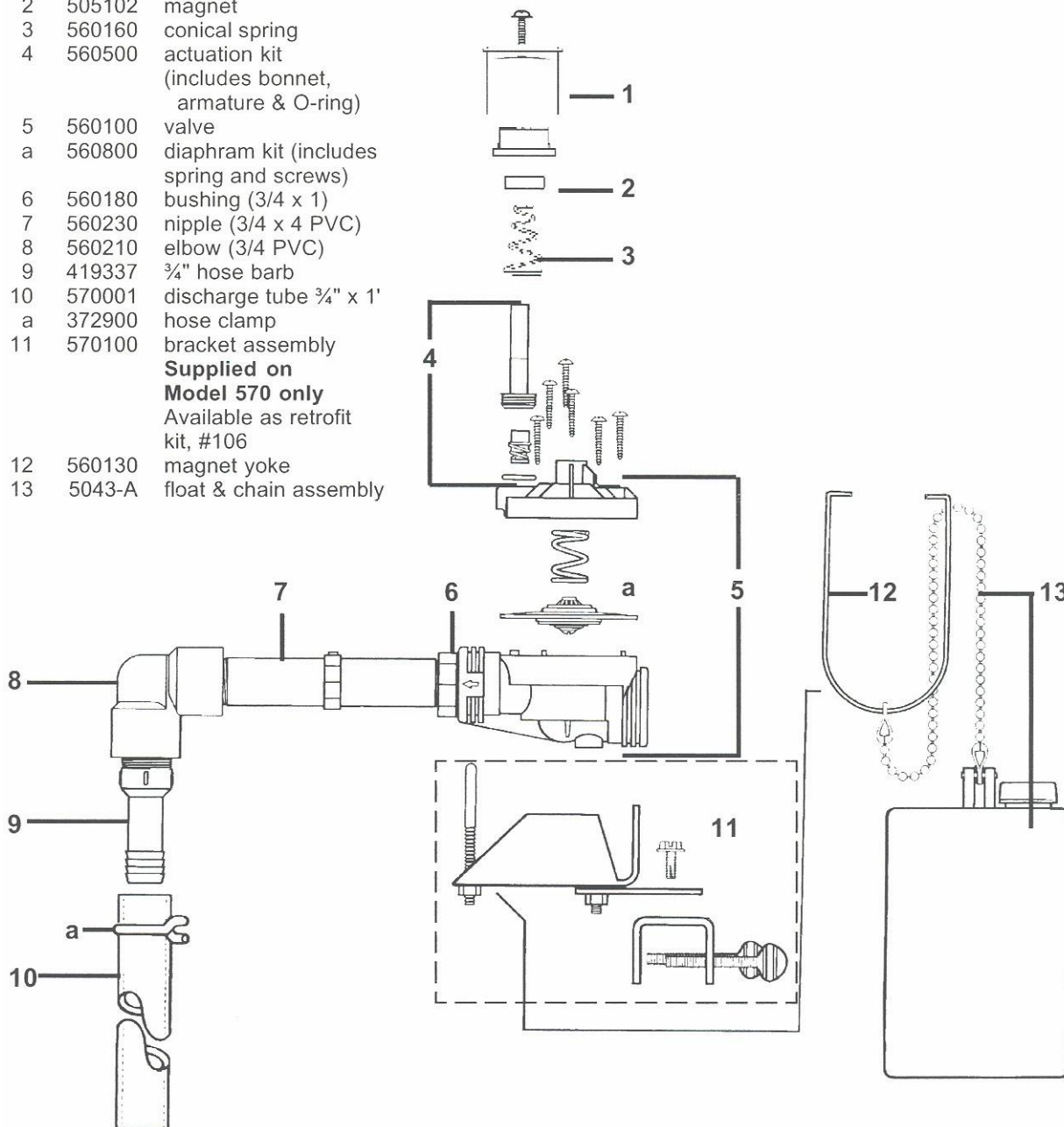

Supplied on Model 570 only
Available as retrofit kit, #106

HydroMinder Model 507

Package Contains:

1. Proportioner
2. Float with chain
3. Suction tube with foot valve -- 9 ft.
4. Discharge tube -- 2 ft.
5. Metering tip kit (14 tips)
6. Production information sheet

THANK YOU FOR YOUR INTEREST IN OUR PRODUCTS

Please use this equipment carefully and observe all warnings and cautions.

***** NOTE *****

| | |
|---------------|--|
| WEAR | protective clothing and eyewear when dispensing chemicals or other materials. |
| ALWAYS | observe safety and handling instructions of the chemical manufacturers. |
| ALWAYS | direct discharge away from you or other persons or into approved containers. |
| ALWAYS | dispense cleaners and chemicals in accordance with manufacturer's instructions. Exercise CAUTION when maintaining your equipment. |
| KEEP | equipment clean for proper operation. |
| WEAR | protective clothing and eyewear when working in the vicinity of all chemicals, filling or emptying equipment or changing metering tips. |
| ALWAYS | re-assemble equipment according to instruction procedures. Be sure all components are firmly screwed or latched into position. |
| ATTACH | only to tap water outlets (85 PSI maximum). |

Through proper care and maintenance, this equipment will serve your toughest cleaning jobs.

Installation:

1. Select a metering tip (see next three sections) and insert it into the suction stub on the eductor body.
 2. Attach the end of the discharge tube with the clamp and flooding ring to the discharge barb on the eductor. Since the proportioner does not have a siphon breaker, you may want to drill a small hole (1/8" or 1/4" ID) in the discharge tube, above the highest solution level and below the discharge end of the eductor. This will allow the discharge tube to drain after each cycle.
 3. Mount the unit in a level position on the side of the reservoir.
 4. Insert the foot valve end of the suction tube into the concentrate container. (The level of the concentrate must be below the level of the eductor, or the proportioner will continue to siphon concentrate after it is turned "off".)
 5. Slide the open end of the suction tube over the suction stub.
 6. Adjust the bead chain length to position the float at the desired level of solution. To prevent foaming, be certain that the solution level will always be above the point of discharge. Be sure float mechanism is not hampered by water turbulence caused by discharging solution. It may be necessary to baffle the float from the discharge in order for the unit to work properly.
2. Install a minimum 1/2-inch ID water hose between the inlet threads and the water spigot. Minimum water pressure required to properly operate the proportioner is 25 PSI (flowing).

Measurement of Concentration:

You can determine the dispensed water-to-product ratio for any metering tip size and product viscosity. All that is required is to operate the primed dispenser for a minute or so and note two things: the amount of dispensed water/product mixture, and the amount of concentrate used in preparation of the solution dispensed. The water-to-product ratio is then calculated as follows:

$$\text{Dilution (X)} = \frac{\text{Amount of Mixed Solution} - \text{Amount of Concentrate Drawn}}{\text{Amount of Concentrate Drawn}}$$

Dilution ratio, then, equals X parts water to one part concentrate (X:1). If the test does not yield the desired ratio, choose a different tip and repeat the test. Alternative methods to this test are 1) pH (using litmus paper), and 2) titration. Contact your concentrate supplier for further information on these alternative methods and the materials required to perform them.

| APPROXIMATE DILUTIONS AT 40 PSI FOR WATER-THIN PRODUCTS (1.0 CP) | | | |
|---|--------------|---------------------|-------|
| Tip Color | Orifice Size | (Std. Drill Number) | Ratio |
| No Tip | .187 | (3/16) | 4:1 |
| Grey | .128 | (30) | 5:1 |
| Black | .098 | (40) | 6:1 |
| Beige | .070 | (50) | 8:1 |
| Red | .052 | (55) | 17:1 |
| White | .043 | (57) | 23:1 |
| Blue | .040 | (60) | 25:1 |
| Tan | .035 | (65) | 36:1 |
| Green | .028 | (70) | 48:1 |
| Orange | .025 | (72) | 64:1 |
| Brown | .023 | (74) | 75:1 |
| Yellow | .020 | (76) | 90:1 |
| Purple | .014 | (79) | 120:1 |
| Pink | .010 | (87) | 240:1 |

Metering Tip Selection:

The final concentration of the dispensed liquid is related to both the size of the metering tip opening (orifice) and the viscosity of the liquid being siphoned. If product viscosity is noticeably greater than that of water, consult the procedure for Measurement of Concentration on the first page to achieve your desired water-to-product ratio. For water-thin products, use the chart at right as a guideline. Because such factors as inlet water pressure and temperature can affect dilution ratios, the figures listed below are only approximate. Test the actual dilution you are achieving using the Measurement of Concentration procedure for best results. Two undrilled, clear tips are supplied for drilling sizes not listed.

Operation:

Open the water supply ball valve. When the solution in the reservoir reaches the level set by the float, the valve will close. This will stop the water flow and siphoning of concentrate. When withdrawal of solution from the reservoir causes the level to drop more than 1-1/2 inches, the valve will open, and the reservoir will be refilled to the previous, pre-set level. This cycle will be repeated automatically until the supply of concentrate is depleted. The ball valve should be **fully closed** when changing metering tips or concentrate container, when reservoir is drained, or when the unit is not in use.

Troubleshooting:

| Problem | Probable Cause | Remedy |
|--|---|--|
| 1. No discharge | a. No water b. Defective magnetic valve assembly c. Excessive water pressure | a. Open water inlet b. Replace assembly c. Install regulator if pressure exceeds 85 PSI |
| 2. No concentrate draw | a. Clogged foot valve b. Metering tip or eductor clogged c. Low water pressure d. Discharge tube or flooding ring not in place | a. Clean or replace foot valve b. Clean* or replace c. Minimum 25 PSI flowing required d. Check position: Replace discharge tube if flooding ring is missing. |
| 3. Failure of unit to turn off | a. Valve parts dirty or defective b. Magnet spring too short c. Clogged valve orifice | a. Clean or replace b. Replace c. Clean or replace |
| 4. Backflow into concentrate | a. Diluted solution being siphoned into container b. Water being siphoned into container | a. Replace or repair foot valve b. Replace eductor |
| * In hard water areas, scale may form at the discharge of the eductor. This scale may be removed by soaking the eductor in a descaling solution or by running the descaling solution through the system. If descaling solution is educted through the system, flush the unit by educting water only before returning the system to regular use. | | |

Parts Diagram/List

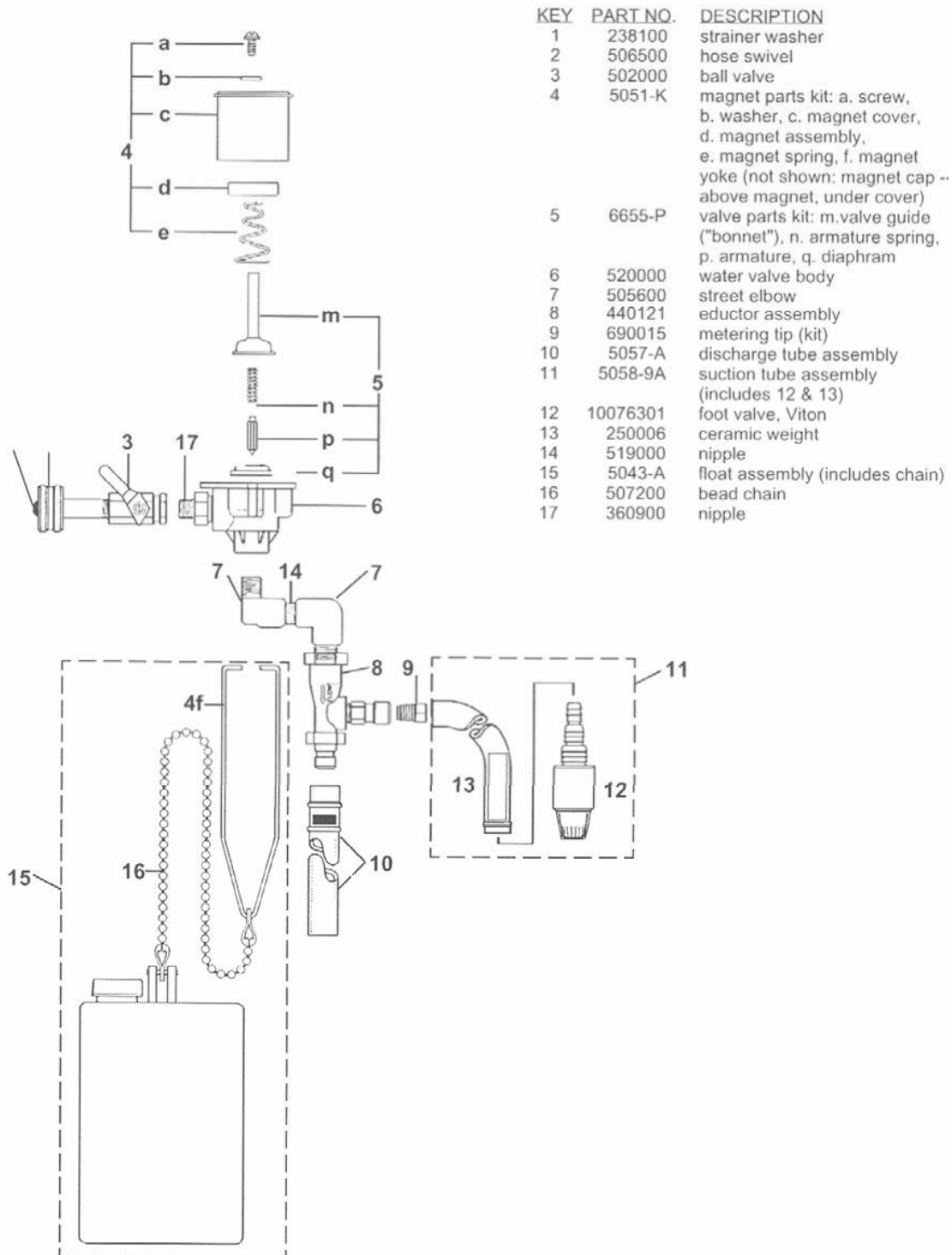

HydroMinder Model 506

Package Contains:

1. Proportioner with U-clamp for mounting
2. Float with chain
3. Suction tube with foot valve -- 9 ft.
4. Discharge tube -- 2 ft.
5. Metering tip kit (14 tips)
6. Production information sheet

THANK YOU FOR YOUR INTEREST IN OUR PRODUCTS

Please use this equipment carefully and observe all warnings and cautions.

..... NOTE

| | |
|---------------|--|
| WEAR | protective clothing and eyewear when dispensing chemicals or other materials. |
| ALWAYS | observe safety and handling instructions of the chemical manufacturers. |
| ALWAYS | direct discharge away from you or other persons or into approved containers. |
| ALWAYS | dispense cleaners and chemicals in accordance with manufacturer's instructions. Exercise CAUTION when maintaining your equipment. |
| KEEP | equipment clean for proper operation. |
| WEAR | protective clothing and eyewear when working in the vicinity of all chemicals, filling or emptying equipment or changing metering tips. |
| ALWAYS | re-assemble equipment according to instruction procedures. Be sure all components are firmly screwed or latched into position. |
| ATTACH | only to tap water outlets (85 PSI maximum). |

Through proper care and maintenance, this equipment will serve your toughest cleaning jobs.

Installation:

1. Select a metering tip (see next three sections) and insert it into the suction stub on the eductor body.
2. Attach the end of the discharge tube with the clamp and flooding ring to the discharge barb on the eductor. Since the HydroMinder 506 does not have a siphon breaker, you may want to drill a small hole (1/8" or 1/4" ID) in the discharge tube, above the highest solution level and below the discharge end of the eductor. This will allow the discharge tube to drain after each cycle.
3. Mount the unit in a level position on the side of the reservoir. The U-clamp may be repositioned or removed as necessary.
4. Insert the foot valve end of the suction tube into the concentrate container. (The level of the concentrate must be below the level of the eductor, or the proportioner will continue to siphon concentrate after it is turned "off".)
5. Slide the open end of the suction tube over the suction stub.
6. Adjust the bead chain length to position the float at the desired level of solution. To prevent foaming, be certain that the solution level will always be above the point of discharge. Be sure float mechanism is not hampered by water turbulence caused by discharging solution. It may be necessary to baffle the float from the discharge in order for the unit to work properly.
7. Install a minimum 1/2 inch ID water hose between the inlet threads and the water spigot. Minimum water pressure required to properly operate the proportioner is 25 PSI (flowing).

Measurement of Concentration:

You can determine the dispensed water-to-product ratio for any metering tip size and product viscosity. All that is required is to operate the primed dispenser for a minute or so and note two things: the amount of dispensed water/product mixture, and the amount of concentrate used in preparation of the solution dispensed. The water-to-product ratio is then calculated as follows:

$$\text{Dilution (X)} = \frac{\text{Amount of Mixed Solution} - \text{Amount of Concentrate Drawn}}{\text{Amount of Concentrate Drawn}}$$

Dilution ratio, then, equals X parts water to one part concentrate (X:1). If the test does not yield the desired ratio, choose a different tip and repeat the test. Alternative methods to this test are 1) pH (using litmus paper), and 2) titration. Contact your concentrate supplier for further information on these alternative methods and the materials required to perform them.

| APPROXIMATE DILUTIONS AT 40 PSI FOR WATER-THIN PRODUCTS (1.0 CP) | | | |
|---|--------------|---------------------|-------|
| Tip Color | Orifice Size | (Std. Drill Number) | Ratio |
| No Tip | .187 | (3/16) | 4:1 |
| Grey | .128 | (30) | 5:1 |
| Black | .098 | (40) | 6:1 |
| Beige | .070 | (50) | 8:1 |
| Red | .052 | (55) | 17:1 |
| White | .043 | (57) | 23:1 |
| Blue | .040 | (60) | 25:1 |
| Tan | .035 | (65) | 36:1 |
| Green | .028 | (70) | 48:1 |
| Orange | .025 | (72) | 64:1 |
| Brown | .023 | (74) | 75:1 |
| Yellow | .020 | (76) | 90:1 |
| Purple | .014 | (79) | 120:1 |
| Pink | .010 | (87) | 240:1 |

Metering Tip Selection:

The final concentration of the dispensed liquid is related to both the size of the metering tip opening (orifice) and the viscosity of the liquid being siphoned. If product viscosity is noticeably greater than that of water, consult the procedure for Measurement of Concentration on the first page to achieve your desired water-to-product ratio. For water-thin products, use the chart at right as a guideline. Because such factors as inlet water pressure and temperature can affect dilution ratios, the figures listed below are only approximate. Test the actual dilution you are achieving using the Measurement of Concentration procedure for best results. Two undrilled, clear tips are supplied for drilling sizes not listed.

Operation:

Open the water supply ball valve. When the solution in the reservoir reaches the level set by the float, the valve will close. This will stop the water flow and siphoning of concentrate. When withdrawal of solution from the reservoir causes the level to drop more than 1-1/2 inches, the valve will open, and the reservoir will be refilled to the previous, pre-set level. This cycle will be repeated automatically until the supply of concentrate is depleted. The ball valve should be **fully closed** when changing metering tips or concentrate container, when reservoir is drained, or when the unit is not in use.

Troubleshooting:

| Problem | Probable Cause | Remedy |
|--|---|--|
| 1. No discharge | a. No water b. Defective magnetic valve assembly c. Excessive water pressure | a. Open water inlet b. Replace assembly c. Install regulator if pressure exceeds 85 PSI |
| 2. No concentrate draw | a. Clogged foot valve b. Metering tip or eductor clogged c. Low water pressure d. Discharge tube or flooding ring not in place | a. Clean or replace foot valve b. Clean* or replace c. Minimum 25 PSI flowing required d. Check position: Replace discharge tube if flooding ring is missing. |
| 3. Failure of unit to turn off | a. Valve parts dirty or defective b. Magnet spring too short c. Clogged valve orifice | a. Clean or replace b. Replace c. Clean or replace |
| 4. Backflow into concentrate | a. Diluted solution being siphoned into container b. Water being siphoned into container | a. Replace or repair foot valve b. Replace eductor |
| * In hard water areas, scale may form at the discharge of the eductor. This scale may be removed by soaking the eductor in a descaling solution or by running the descaling solution through the system. If descaling solution is educted through the system, flush the unit by educting water only before returning the system to regular use. | | |

HydroMinder Model 506 Parts Diagram/List

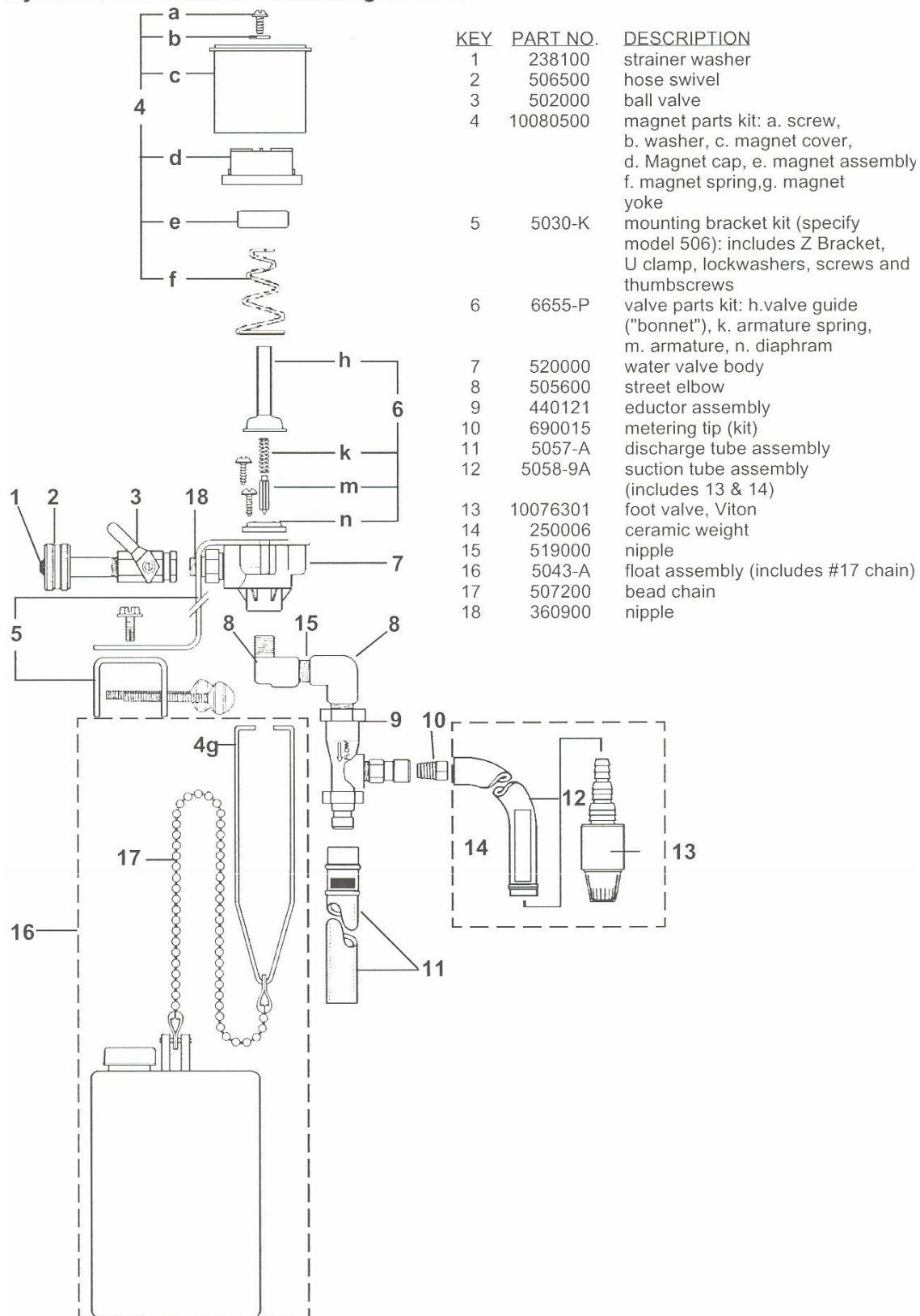



Pneumatic Division North America
Richland, Michigan 49083

Installation & Service Instructions
2FR100FP
05E, 06E, 07E, & 12E
Filter / Regulator Series
ISSUED: September, 2000
Supersedes: July, 1999
ECN# P27805

⚠ WARNING

To avoid unpredictable system behavior that can cause personal injury and property damage:

- Disconnect electrical supply (when necessary) before installation, servicing, or conversion.
- Disconnect air supply and depressurize all air lines connected to this product before installation, servicing, or conversion.
- Operate within the manufacturer's specified pressure, temperature, and other conditions listed in these instructions.
- Medium must be moisture-free if ambient temperature is below freezing.
- Service according to procedures listed in these instructions.
- Installation, service, and conversion of these products must be performed by knowledgeable personnel who understand how pneumatic products are to be applied.
- After installation, servicing, or conversion, air and electrical supplies (when necessary) should be connected and the product tested for proper function and leakage. If audible leakage is present, or the product does not operate properly, do not put into use.
- Warnings and specifications on the product should not be covered by paint, etc. If masking is not possible, contact your local representative for replacement labels.

Introduction

Follow these instructions when installing, operating, or servicing the product.

Application Limits

These products are intended for use in general purpose compressed air systems only.

With Polycarbonate Bowl

| | kPa | PSIG | bar |
|-------------------------------|------|--------------|------|
| Operating Pressure Maximum | 1000 | 150 | 10.3 |
| Operating Temperature Maximum | | 52°C (125°F) | |
| Operating Temperature Minimum | | 0°C (32°F) | |

With Metal Bowl

| | kPa | PSIG | bar |
|-------------------------------|------|--------------|------|
| Operating Pressure Maximum | 1700 | 250 | 17.0 |
| Operating Temperature Maximum | | 80°C (175°F) | |
| Operating Temperature Minimum | | 0°C (32°F) | |

05/15 Series with Metal Bowl and Auto Drain

| | kPa | PSIG | bar |
|-------------------------------|------|--------------|------|
| Operating Pressure Maximum | 1000 | 150 | 10.3 |
| Operating Temperature Maximum | | 80°C (175°F) | |
| Operating Temperature Minimum | | 0°C (32°F) | |

Note: The maximum recommended pressure drop for a particulate filter is 70 kPa (10 PSIG, 0.7 bar)

Symbols



Installation

1. The Filter / Regulator should be installed with reasonable accessibility for service whenever possible – repair service kits are available. Keep pipe or tubing lengths to a minimum with inside clean and free of dirt and chips. Pipe joint compound should be used sparingly and applied only to the male pipe – never into the female port. Do not use PTFE tape to seal pipe joints – pieces have a tendency to break off and lodge inside the unit, possibly causing malfunction. Also, new pipe or hose should be installed between the Filter / Regulator and equipment being protected.
2. The upstream pipe work must be clear of accumulated dirt and liquids.
3. Select a Filter / Regulator location as close as possible to the equipment being protected.

4. Install Filter / Regulator so that air flows in the direction of arrow on body.
5. Install Filter / Regulator vertically with the bowl drain mechanism at the bottom. Free moisture will thus drain into the sump ("quiet zone") at the bottom of the bowl.
6. Gauge ports are located on both sides of the filter/regulator body for your convenience. It is necessary to install a gauge or socket pipe plugs into each port during installation.

Operation

1. Both free moisture and solids are removed automatically by the filter. Units with coalescing elements (e.g. 12E series) also remove oil. For coalescing units, a 5 micrometer pre-filter is recommended to protect and prolong the life of the coalescent filter element.
2. Manual drain filters must be drained regularly before the separated moisture and oil reaches the bottom of the baffle or end cap.
3. The filter element should be removed and replaced when pressure differential across the filter is 69 kPa (10 psig).
4. Before turning on the air supply, turn the knob counterclockwise until compression is released from the pressure control spring. Then turn knob clockwise and adjust regulator to desired downstream pressure. This permits pressure to build up slowly in the downstream line.
5. To decrease regulated pressure settings, always reset from a pressure lower than the final setting required. Example, lowering the secondary pressure from 550 to 410 kPa (80 to 60 psig) is best accomplished by dropping the secondary pressure to 350 kPa (50 psig), then adjusting upward to 410 kPa (60 psig).
6. When desired secondary pressure settings have been reached, push the knob down to lock this pressure setting.

Service

⚠ Caution: Disconnect or shut off air supply and exhaust the primary and secondary pressures before servicing unit. Turning the adjusting knob counterclockwise does not vent downstream pressure on non-relieving regulators. Downstream pressure must be vented before servicing regulator.

Note: Grease packets are supplied with kits for lubrication of seals. Use only mineral based grease or oils. Do not use synthetic oils such as esters. Do not use silicones.

Note: After servicing unit, turn on air supply and adjust regulator to the desired downstream pressure. Check unit for leaks. If leakage occurs, do not operate - conduct repairs and retest.

Servicing Filter Element -

- A. 05E, 06E, & 07E Units (Refer to Figure 1.)
 1. Unscrew the bottom threaded collar and remove bowl.
 2. Unscrew the baffle and then remove element.
 3. Clean all internal parts and bowl before reassembling. See polycarbonate bowl cleaning section. IMPORTANT: The 05E & 06E Filter/Regulator will

⚠ WARNING

FAILURE OR IMPROPER SELECTION OR IMPROPER USE OF THE PRODUCTS AND/OR SYSTEMS DESCRIBED HEREIN OR RELATED ITEMS CAN CAUSE DEATH, PERSONAL INJURY AND PROPERTY DAMAGE.

This document and other information from Parker Hannifin Corporation, its subsidiaries and authorized distributors provide product and/or system options for further investigation by users having technical expertise. It is important that you analyze all aspects of your application, including consequences of any failure and review the information concerning the product or systems in the current product catalog. Due to the variety of operating conditions and applications for these products or systems, the user, through its own analysis and testing, is solely responsible for making the final selection of the products and systems and assuring that all performance, safety and warning requirements of the application are met.

The products described herein, including without limitation, product features, specifications, designs, availability and pricing, are subject to change by Parker Hannifin Corporation and its subsidiaries at any time without notice.

EXTRA COPIES OF THESE INSTRUCTIONS ARE AVAILABLE FOR INCLUSION IN EQUIPMENT / MAINTENANCE MANUALS THAT UTILIZE THESE PRODUCTS. CONTACT YOUR LOCAL REPRESENTATIVE.

05E, 06E, 07E, & 12E Filter/Regulator Series

- not operate properly if the deflector (or rubber spacer if using an 06E adsorber) is not installed properly. The deflector (or rubber spacer) must be installed between the filter stem and the filter body.
- Install new element.
 - Attach baffle and finger tighten firmly.
 - Replace bowl seal. Lightly lubricate new seal to assist with retaining it in position.
 - Install bowl into body and tighten collar; hand tight, plus 1/4 turn.
- B. 12E Units** (Refer to Figure 2.)
- Hold bowl collar stationary while unscrewing and removing bowl.
 - Unscrew end cap and then remove element. (Do not remove threaded rod.)
 - Clean all internal parts and bowl before reassembling.
 - Install new element.
 - Attach end cap and finger tighten firmly.
 - Replace bowl seal. Lightly lubricate new seal to assist with retaining it in position.
 - Thread bowl into collar; hand tighten until bowl stops against collar.

Servicing Regulator -

- A. 05E, 06E, & 07E Units** - (Refer to Figure 1.)
- Disengage the adjusting knob by pulling upward. Turn adjusting knob counterclockwise until the compression is released from the pressure control spring.
 - Remove the bonnet and bowl assemblies by unscrewing the two threaded collars.
 - Remove diaphragm assembly from bonnet assembly.
 - Remove filter stem, filter element, poppet assembly, poppet return spring, (seat) insert and its o-rings.
 - Clean and carefully inspect parts for wear or damage. If replacement is necessary, use parts from service kits. Clean bowl. See polycarbonate bowl cleaning section.
 - Lubricate o-ring and vee packing seals with grease found in service kits.
 - Install poppet return spring, poppet assembly, (seat) insert and its o-rings, and filter stem. **IMPORTANT:** The 05E & 06E Filter/Regulator will not operate properly if the deflector (or rubber spacer if using an 06E adsorber) is not installed properly. The deflector (or rubber spacer) must be installed between the filter stem and filter body.
 - Install filter element and firmly tighten baffle onto the filter stem.
 - Install diaphragm assembly into bonnet assembly. Assemble bonnet assembly to body and tighten threaded collar from 5.4 to 5.9 Nm (48 to 52 in-lbs).
 - Install bowl into body and tighten collar; hand tight, plus 1/4 turn.
- B. 12E Units** - (Refer to Figure 2.)
- Disengage the adjusting knob by pulling upward. Turn adjusting knob counterclockwise until the compression is released from the pressure control spring.
 - Remove the bonnet assembly by unscrewing its threaded collar.
 - Remove the bottom collar and bowl as an integral unit. Note: The reverse flow adapter and element assembly should remain in proper alignment with the collar; they are held in place by the o-ring between the adapter and the collar.
 - Remove diaphragm assembly from bonnet assembly.
 - Remove poppet assembly, poppet return spring, (seat) insert and its o-rings.

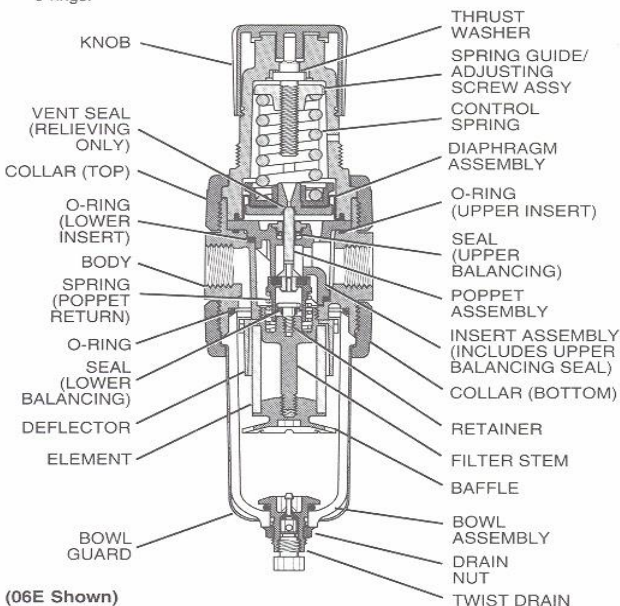

Figure 1: 05E, 06E, & 07E

2FR100FP

- Clean and carefully inspect parts for wear or damage. If replacement is necessary, use parts from service kits.
- Lubricate o-ring and vee packing seals with grease found in service kits.
- Install poppet return spring, poppet assembly, (seat) insert and its o-rings.
- Install diaphragm assembly into bonnet assembly. Assemble bonnet assembly to body and tighten threaded collar from 5.4 to 5.9 Nm (48 to 52 in-lbs).
- Install bottom collar and bowl subassembly into body. Tighten collar hand tight, plus 1/4 turn.

Safety: Polycarbonate Bowls

⚠ CAUTION

Polycarbonate bowls, being transparent and tough, are ideal for use with Filters and Lubricators. They are suitable for use in normal industrial environments, but should not be located in areas where they could be subjected to direct sunlight, an impact blow, nor temperatures outside of the rated range. As with most plastics, some chemicals can cause damage. Polycarbonate bowls should not be exposed to chlorinated hydrocarbons, ketones, esters and certain alcohols. They should not be used in air systems where compressors are lubricated with fire-resistant fluids such as phosphate ester and di-ester types.

Metal bowls are recommended where ambient and/or media conditions are not compatible with polycarbonate bowls. Metal bowls resist the action of most such solvents, but should not be used where strong acids or bases are present or in salt laden atmospheres. Consult the factory for specific recommendations where these conditions exist.

TO CLEAN POLYCARBONATE BOWLS USE MILD SOAP AND WATER ONLY! DO NOT use cleansing agents such as acetone, benzene, carbon tetrachloride, gasoline, toluene, etc., which are damaging to this plastic.

Bowl guards are recommended for added protection of polycarbonate bowls where chemical attack may occur.

⚠ WARNING

To avoid polycarbonate bowl rupture that can cause personal injury or property damage, do not exceed bowl pressure of temperature ratings. Polycarbonate bowls have a 150 psig (1030 kPa) pressure rating and a maximum temperature rating of 52°C (125°F).

| MAINTENANCE SERVICE KITS | 05E 1/8", 1/4" & 3/8" | 06E 1/4", 3/8" & 1/2" | 07E 3/8", 1/2" & 3/4" | 12E 3/8", 1/2" & 3/4" |
|------------------------------------|--------------------------|--------------------------|--------------------------|--------------------------|
| Element Kits | | | | |
| 5 Micron | PS902P | PS702P | PS802P | N/A |
| 40 Micron | PS901P | PS701P | PS801P | N/A |
| Grade 6 | N/A | N/A | N/A | PS884P |
| Grade 10 | N/A | N/A | N/A | PS885P |
| Relieving Regulator Repair Kit | PS908P | PS710P | PS810P | PS886P |
| Non-Relieving Regulator Repair Kit | PS909P | PS711P | PS811P | PS887P |

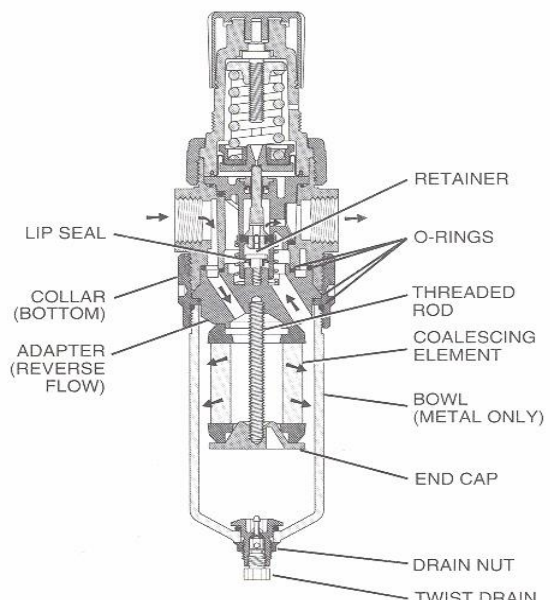

Figure 2: 12E

Piggybacks



Parker 06E/07E Filter/Regulator “piggybacks” combine the fine features of the filter and regulator into an integral space saving package. They are designed to provide minimum pressure drop over a wide operating range. With a non-rising adjustment knob as standard, this series offers an economical and attractively styled alternative.

Features

- Excellent water removal efficiency.
- Space saving package offers both filter and regulator features in one integral unit.
- Non-rising adjustment knob.
- Rolling diaphragm for extended life.
- Quick response, and accurate pressure regulation regardless of changing flow or inlet pressure.
- Two full flow 1/4" gauge ports.
- 40 micron element standard.

Operation

Turning the knob (A) clockwise applies a load to control spring (F) which forces the diaphragm (H) and valve poppet assembly (C) to move downward allowing filtered air to flow through the seat area (I) created between the poppet assembly and the seat. **“First stage filtration”** begins when air pressure supplied to the inlet port is directed through deflector plate (D) causing a swirling centrifugal action forcing liquids and coarse particles to the inner bowl wall (E) and down below the lower baffle to the quiet zone. After liquids and large particles are removed in the first stage of filtration **“second stage filtration”** occurs as air flows through element (J) where smaller particles are filtered out and retained. The air flow now passes through seat area (I) to the outlet port of the unit. Pressure in the downstream line is sensed below the diaphragm (H) and offsets the load of spring (F). When downstream pressure reaches the set-point, poppet valve assembly (C) and diaphragm (H) move upward closing seat area (I). Should downstream pressure exceed the desired regulated pressure, the excess pressure will cause the diaphragm (H) to move upward opening vent hole (B) venting the excess pressure to atmosphere through the hole in the bonnet (G). (This occurs in the standard relieving type regulator only.)

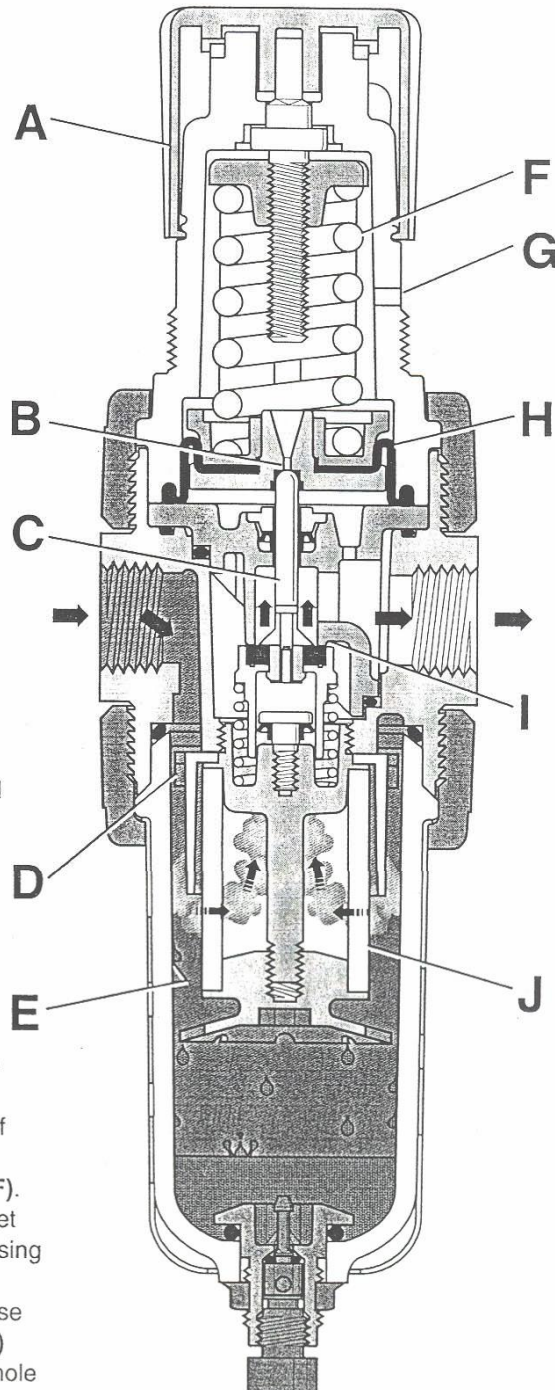



OPERATING INSTRUCTIONS
SPDT TEMPERATURE CONTROL
MODEL 2E399

FORM
5S1776
09314

0589/176/1M

READ CAREFULLY BEFORE ATTEMPTING TO INSTALL OR OPERATE THE DAYTON SPDT TEMPERATURE CONTROL. FAILURE TO COMPLY WITH INSTRUCTIONS COULD RESULT IN PERSONAL INJURY AND/OR PROPERTY DAMAGE!

RETAIN INSTRUCTIONS FOR FUTURE REFERENCE.

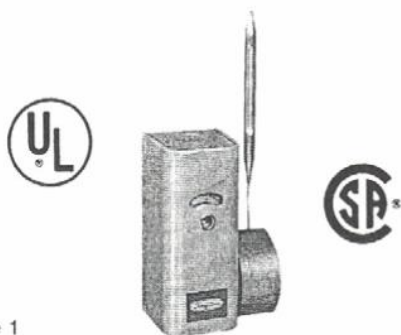

Figure 1

Description

The Dayton temperature control is designed for use on equipment that requires a closed circuit for both rise and fall in temperature. Its single pole, double throw switch action offers both open-on-rise terminals as well as close-on-rise terminals.

In addition to general use, this control is also suitable for use as an outdoor thermostat or as a change-over control.

A mounting bracket is furnished for mounting the bulb. The control has capillary tubing between the temperature sensitive bulb and the switch mechanism, permitting the switch mechanism to be mounted at any convenient location while the temperature sensitive bulb is located in the fluid or medium being controlled.

Specifications

| | |
|--------------------------------|------------------------------|
| Range | -30° to +90°F |
| Differential | Adjustable from 4½ to 40°F |
| Switch action | SPDT |
| Capillary length | 8 Ft |
| Bulb size | 5¼ x 3/8" |
| A.C. Electrical rating: | |
| Motor rating (full load) | { 7.4A @ 120V 3.7A @ 240V |
| Valves and relays | 2.9A @ 25V, 2.9A @ 120V |
| Approvals | UL listed, CSA certified |

General Safety Information

1. Make certain that electrical ratings of control conform to the power source and to the load(s) being controlled. Loads exceeding the rating of the control should be handled with a suitably rated relay or motor starter.

2. Disconnect all power before installing or servicing. If the power disconnect is out-of-sight, lock it in the open position and tag it to prevent unexpected application of power. Failure to do so could result in fatal electric shock.

WARNING: DO NOT DEPEND UPON THE CONTROL AS THE SOLE MEANS OF DISCONNECTING POWER WHEN INSTALLING OR SERVICING THE PRODUCT IT IS CONTROLLING. ALWAYS DISCONNECT POWER AT THE MAIN CIRCUIT BREAKER AS DESCRIBED ABOVE. FAILURE TO DO SO COULD RESULT IN FATAL ELECTRIC SHOCK.

3. Special attention must be given to any grounding information pertaining to this control and to any other equipment associated with its installation and use. To ensure a proper ground, the grounding means must be checked by a qualified electrician.
4. This control is intended ONLY for permanent installation in accordance with the National Electrical Code (NEC), all applicable local codes and ordinances, and all sections of this manual. All wiring should be done by a qualified electrician, using copper wire only.
5. This thermostat is intended for general use ONLY. It must NOT be used in potentially dangerous locations such as flammable, explosive, chemical-laden or wet atmospheres.
6. Use this control as an operating control only, and never as a high limit control. If required, a separate suitably rated high limit control should be used.
7. In cases in which property damage may result from malfunction of the control, a backup system should be used. Where critical or high value products are to be maintained, an approved temperature limit should be wired in series with this control. In less critical applications, a thermostat with alarm contacts can be used to provide redundancy.

Installation

1. The switch mechanism of this control may be mounted in any location provided that the temperature and humidity of the air in which it is located do not cause a condensation on the switch parts.
2. The sensitive element or "bulb" should be located in the average temperature of the controlled area.
3. Capillary tubing should be led over a path that protects it from injury from blows, cuts, etc., avoid kinking and twisting. It should be attached to some surface at frequent points along its length and not be permitted to hang loosely. Excessive capillary should be coiled and secured at some convenient protected location close to the switch mechanism.

37-2143-B
Replaces 37-2143-1

Printed in U.S.A.

FORM 5S1776

MODEL 2E399

09314

Installation (Continued)

- The bulb should be handled with reasonable care also. A dent or sharp bend may change the calibration and cause the control to cycle at a temperature different than the dial setting.

WIRING

WARNING: ALL WIRING SHOULD BE DONE ACCORDING TO LOCAL AND NATIONAL ELECTRICAL CODES AND ORDINANCES.

This control has a single-pole, double-throw snap action switch. The top left-hand terminal (red) is the common terminal. The top right-hand terminal (blue) has open-on-rise switch action. The bottom center terminal (white) has close-on-rise switch action.

INSTALLATION OF OUTDOOR BULB

When used as a changeover control or outdoor thermostat, the bulb of this control should be located so as to measure the actual outdoor air temperature. A mounting bracket is provided on some models for mounting the bulb.

The mounting bracket should be fastened to some convenient outside part of the building that is shielded from the direct rays of the sun, the direct fall of rain and snow, and sufficiently above the ground to keep it out of snow and ice.

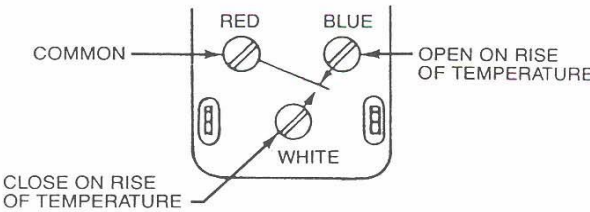
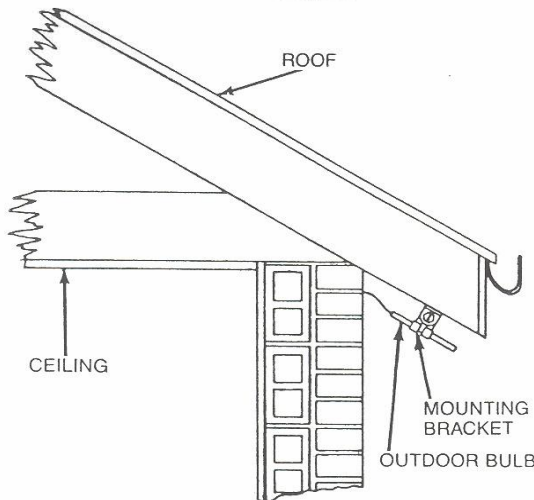

Figure 2 — Terminal Identification



The underside of the eaves or overhang of a NORTH or NORTHEAST roof is a good location. It should be exposed to the circulation of air and wind.

Figure 3 — Installation of Outdoor Bulb

Operation

SETTING

- Insert screwdriver in the center slot and turn the dial until the right hand indicator "B" points to the lowest temperature of the cycle.
- Turn the differential adjusting screw "C" until the left hand indicator "D" points to the highest temperature of the cycle.

Indicator "B" points to temperature at which R-B contacts are to close (and R-W contacts are to open).

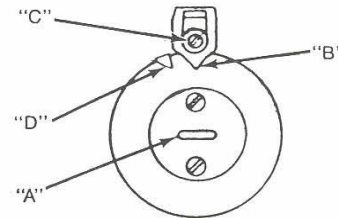

Figure 4 — Dial Settings

LIMITED WARRANTY

DAYTON ONE-YEAR LIMITED WARRANTY. SPDT temperature control, Model 2E399, is warranted by Dayton Electric Mfg. Co. (Dayton) to the original user against defects in workmanship or materials under normal use for one year after date of purchase. Any part which is determined by Dayton to be defective in material or workmanship and returned to an authorized service location, as Dayton designates, shipping costs prepaid, will be, as the exclusive remedy, repaired or replaced at Dayton's option. For limited warranty claim procedures, see PROMPT DISPOSITION below. This limited warranty gives purchasers specific legal rights which vary from state to state.

LIMITATION OF LIABILITY. To the extent allowable under applicable law, Dayton's liability for consequential and incidental damages is expressly disclaimed. Dayton's liability in all events is limited to, and shall not exceed, the purchase price paid.

WARRANTY DISCLAIMER. Dayton has made a diligent effort to illustrate and describe the product in this literature accurately; however, such illustrations and descriptions are for the sole purpose of identification, and do not express or imply a warranty that the product is merchantable, or fits a particular purpose, or that the product will necessarily conform to the illustrations or descriptions.

Except as provided below, no warranty or affirmation of fact, expressed or implied, other than as stated in "LIMITED WARRANTY" above is made or authorized by Dayton.

PRODUCT SUITABILITY. Many states and localities have codes and regulations governing sales, construction, installation, and/or use of products for certain purposes, which may vary from those in neighboring areas. While Dayton attempts to assure that its products comply with such codes, it cannot guarantee compliance, and cannot be responsible for how the product is installed or used. Before purchase and use of a product, please review the product application, and national and local codes and regulations, and be sure that the product, installation, and use will comply with them.

Certain aspects of disclaimers are not applicable to consumer products; e.g., (a) some states do not allow the exclusion or limitation of incidental or consequential damages, so the above limitation or exclusion may not apply to you; (b) also, some states do not allow limitations on how long an implied warranty lasts, consequently the above limitation may not apply to you; and (c) by law, during the period of this Limited Warranty, any implied warranties of merchantability or fitness for a particular purpose applicable to consumer products purchased by consumers, may not be excluded or otherwise disclaimed.

PROMPT DISPOSITION. Dayton will make a good faith effort for prompt correction or other adjustment with respect to any product which proves to be defective within limited warranty. For any product believed to be defective within limited warranty, first write or call dealer from whom product was purchased. Dealer will give additional directions. If unable to resolve satisfactorily, write to Dayton at address below, giving dealer's name, address, date and number of dealer's invoice, and describing the nature of the defect. Title and risk of loss pass to buyer on delivery to common carrier. If product was damaged in transit to you, file claim with carrier.

Manufactured for Dayton Electric Mfg. Co.,
5959 W. Howard St., Chicago, IL 60648

5, 7, 15PFR PLUNGER PUMP SERVICE MANUAL



5 FRAME: 310, 340, 350, 311, 341, 351, 317, 347, 357

5 FRAME OEM: 31, 34, 35, 42HS, 43HS, 45

7 FRAME: 530, 550

7 FRAME OEM: 51, 53, 55, 56, 57, 58, 59, 60, 70

15 FRAME: 650, 651, 660, 661, 1050, 1051, 1057

INSTALLATION AND START-UP INFORMATION

Optimum performance of the pump is dependent upon the entire liquid system and will be obtained only with the proper selection, installation of plumbing and operation of the pump and accessories.

SPECIFICATIONS: Maximum specifications refer to individual attributes. It is **not** implied that **all maximums** can be performed **simultaneously**. If more than one maximum is considered, check with your CAT PUMPS supplier to confirm the proper performance and pump selection. Refer to individual pump Data Sheets for complete specifications, parts list and exploded view.

LUBRICATION: Fill crankcase with special CAT PUMP oil per pump specifications [5PFR-18 oz., 7PFR-25 oz., 15PFR-42oz.]. **DO NOT RUN PUMP WITHOUT OIL IN CRANKCASE.** Change initial fill after 50 hours running period. Thereafter, change oil every **3 months or 500 hour intervals**, whichever comes first.

PUMP ROTATION: Pump was designed for forward rotation to allow optimum lubrication of the crosshead area. Reverse rotation is acceptable if the crankcase oil level is increased slightly above center dot to assure adequate lubrication.

PULLEY SELECTION: Select size of motor pulley required to deliver the desired flow from Horsepower Requirement and Pulley Selection Chart (refer to Tech Bulletin 003 or individual Data Sheet).

DRIVE SELECTION: The motor or engine driving the pump must be of adequate horsepower to maintain full RPM when the pump is under load. Select the electric motor from the Horsepower Requirement Chart according to required pump discharge flow, maximum **pressure at the pump** and drive losses of approximately 3-5%. Consult the manufacturer of gas or diesel engine for selection of the proper engine size.

MOUNTING: Mount the pump on a rigid, horizontal surface in a manner to permit drainage of crankcase oil. An uneven mounting surface will cause extensive damage to the pump base. To minimize piping stress, **use appropriate flexible hose to inlet and discharge ports.** Use the correct belt; make sure pulleys are aligned. Excessive belt tension may be harmful to the bearings. Hand rotate pump before starting to be certain shaft and bearings are free moving.

LOCATION: If the pump is used in extremely dirty or humid conditions, it is recommended pump be enclosed. Do not store or operate in excessively high temperature areas or without proper ventilation.

INLET CONDITIONS: Refer to complete **Inlet Condition Check-List** in this manual before starting system. **DO NOT STARVE THE PUMP OR RUN DRY.**

C.A.T.: Installation of a C.A.T. (Captive Acceleration Tube) is recommended in applications with stressful inlet conditions such as high temperatures, booster pump feed, long inlet lines or quick closing valves.

DISCHARGE CONDITIONS: **OPEN ALL VALVES BEFORE STARTING SYSTEM** to avoid deadhead overpressure condition and severe damage to the pump or system.

Install a **Pulsation Dampening** device on the discharge head or in the discharge line as close to the head as possible. Be certain the pulsation dampener (Prrrr-o-lator) is properly precharged for the system pressure (see individual Data Sheet).

A **reliable Pressure Gauge** should be installed near the discharge outlet of the high pressure manifold. This is extremely important for adjusting pressure regulating devices and also for proper sizing of the nozzle or restricting orifice. The pump is rated for a maximum pressure; this is the **pressure** which would be **read at the discharge manifold of the pump, NOT AT THE GUN OR NOZZLE.**

Use PTFE liquid (sparingly) or tape to connect accessories or plumbing. Exercise caution not to wrap tape beyond the last thread to avoid tape from becoming lodged in the pump or accessories. This condition will cause a malfunction of the pump or system.

PRESSURE REGULATION: All systems require both a primary pressure regulating device (i.e., regulator, unloader) and a secondary pressure safety relief device (i.e., pop-off valve, safety valve). The primary pressure device must be installed on the discharge side of the pump. The function of the primary pressure regulating device is to protect the pump from over pressurization, which can be caused by a plugged or closed off discharge line. Over pressurization can severely damage the pump, other system components and can cause bodily harm. The secondary safety relief device must be installed between the primary device and pump. This will ensure pressure relief of the system if the primary regulating device fails. Failure to install such a safety device will void the warranty on the pump.

When the high pressure system is left running with the trigger gun off, the by-pass liquid can be routed to drain or to the pump inlet. If routed to the pump inlet, the **by-pass liquid can quickly develop excessive heat and result in damage to the pump.** A THERMO VALVE installed in the by-pass line is recommended to protect the pump. An AUTO SHUT-OFF ASSEMBLY may also be used.

NOZZLES: A worn nozzle will result in loss of pressure. Do not adjust pressure regulating device to compensate. Replace nozzle and reset regulating device to system pressure.

PUMPED LIQUIDS: Some Liquids may require a **flush between operations or before storing.** For pumping liquids other than water, contact your CAT PUMPS supplier.

STORING: For extended storing or between use in cold climates, drain all pumped liquids from pump and **flush with antifreeze solution to prevent freezing and damage** to the pump. **DO NOT RUN PUMP WITH FROZEN LIQUID** (refer to Tech Bulletin 083).

WARNING

All systems require both a primary pressure regulating device (i.e., regulator, unloader) and a secondary pressure safety relief device (i.e., pop-off valve, safety valve). Failure to install such relief devices could result in personal injury or damage to the pump or to system components. CAT PUMPS does not assume any liability or responsibility for the operation of a customer's high pressure system.

Products described hereon are covered by one or more of the following U.S. patents 3558244, 3652188, 3809508, 3920356, 3930756 and 5035580

World Headquarters

CAT PUMPS

1681 - 94th Lane N.E. Minneapolis, MN 55449-4324

Phone (763) 780-5440 — FAX (763) 780-2958

e-mail: sales@catpumps.com

www.catpumps.com

International Inquiries

FAX (763) 785-4329

e-mail: intl@catpumps.com



"The World's Most Dependable Pumps"

CAT PUMPS (U.K.) LTD.

1 Fleet Business Park, Sandy Lane, Church Crookham, Fleet

Hampshire GU52 9BF, England

Phone Fleet 44 1252-622031 — Fax 44 1252-626655

e-mail: sales@catpumps.co.uk

N.V. CAT PUMPS INTERNATIONAL S.A.

Heiveldekens 6A, 2550 Kontich, Belgium

Phone 32-3-450.7150 — Fax 32-3-450.7151

e-mail: cpi@catpumps.be www.catpumps.be

CAT PUMPS DEUTSCHLAND GmbH

Buchwiese 2, D-65510 Idstein, Germany

Phone 49 6126-9303 0 — Fax 49 6126-9303 33

e-mail: catpumps@t-online.de www.catpumps.de

PN 30002 Rev J 9166

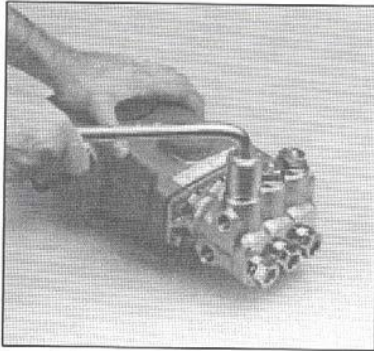

Removal of Valve Plugs

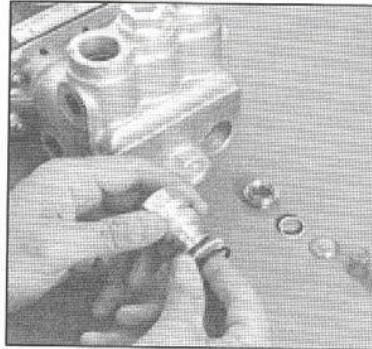

Examination of O-Ring and Back-up-Ring on Valve Plug

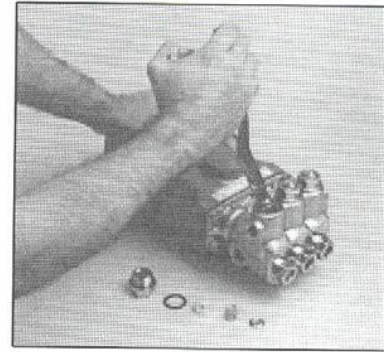

Removal of Valve Assembly

SERVICING THE VALVES

1. Remove the hex Valve Plugs (top discharge, bottom inlet).
2. Examine the O-Ring under the Valve Plug for cuts or distortion and replace if worn. Lubricate new O-Rings before installing.

NOTE: On Models 43HS, 45, 56, 57, 59, 60, 70 there is an extended Valve Plug with O-Ring and Back-up-Ring. Install the Back-up-Ring, then the O-Ring into the groove at the end of the Valve Plug. See Tech Bulletin #058 for model identification.

3. Grasp Valve Retainer by tab at the top with pliers and remove from valve chamber. Usually the valve assembly will remain together while being removed. To separate the valve assembly, insert a screwdriver into the side of the Retainer and press on the back side of the Valve to begin separation, then between the Retainer and Valve Seat to separate completely. If the valve assembly separates during removal, remove the Spring and Valve with a needle nose pliers. Then, with a reverse pliers, remove the Valve Seat from the manifold chamber.
4. Examine all valve parts for pitting, gouges or general wear and replace with preassembled Valve Assembly in service kit containing Retainer, Spring, Valve, Valve Seat, O-Ring and Back-up-Ring.

NOTE: Inlet and discharge valve parts are interchangeable. Two Valve Kits are needed for complete valve change.

5. Grasp new Valve Assembly by tab at top with pliers, immerse in oil and push into valve chamber. Be certain Valve Assembly is completely seated in valve chamber.

NOTE: For certain applications apply liquid gasket to the O-Ring crevices and seal surfaces. See Tech Bulletin #053 for model identification.

NOTE: For Corrosion Resistant Models remember to install the Coil Spring between the Valve Plug and Retainer. Refer to Tech Bulletin #046 for model identification.

6. Apply Loctite 242 to the threads of the Valve Plug, thread into manifold port and torque per chart.

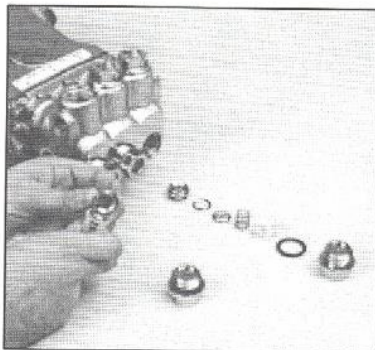

Order of parts in Valve Assembly

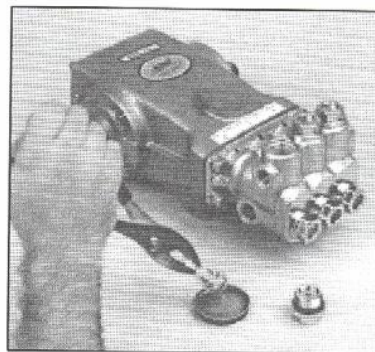

Installation of preassembled Valve Assembly

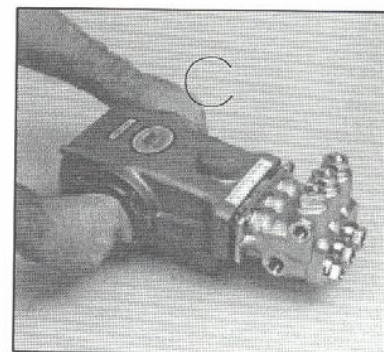

Separating Manifold Head from Crankcase

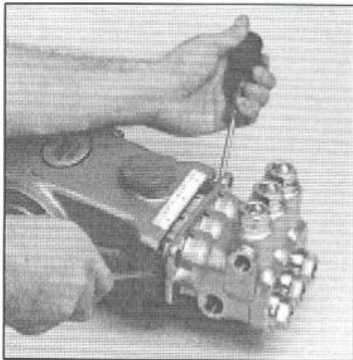

Removal of Manifold Head from Crankcase



Removal of Seal Retainers and Wicks



Proper Alignment of Ceramic Plungers for reassembly

SERVICING THE PUMPING SECTION

Disassembly

1. Using an M8 allen wrench on the 5 Frame pumps, a M14 hex tool on the 7 Frame pumps, or a M17 hex tool on the 15 Frame pumps, remove the two (2) Socket Head Screws, and two (2) Lockwashers or four (4) Flanged Nuts.
2. Rotate Crankshaft by hand to start separation of Manifold head from crankcase.
3. Insert two flat head screwdrivers on opposite sides to further separate Manifold Head from Crankcase or support the underside of the Manifold Head and tap lightly with a mallet on the backside of the Manifold Head.

CAUTION: KEEP MANIFOLD PROPERLY ALIGNED WITH CERAMIC PLUNGERS WHEN REMOVING TO AVOID DAMAGE TO EITHER PLUNGERS OR SEALS.

4. Remove Oil Pan and slide out Seal Retainer with Wick.
5. Examine Ceramic Plunger for cracks or scoring and refer to Servicing Plungers if replacement is needed.

Reassembly

1. Generally Plungers do not need to be replaced. Clean Plungers and remove any foreign material with a non-abrasive cleaner.
2. Saturate new Wick by soaking in oil, place Wick in Rear Seal Retainer and snap Retainer Adapter onto Rear Retainer. Slip Retainer with Wick over Ceramic Plungers with **tab down and wick out**. If new Plungers are installed, **do not lubricate Wicks**. Operate for 24 hours to allow grease from seals to penetrate plunger surface, then lubricate wicks.
3. Replace Oil Pan.
4. Turn shaft by hand to line up plungers so end plungers are parallel.
5. Lightly lubricate the Plungers and carefully slide the Manifold Head onto the plungers supporting from the underside to avoid damaging the plungers. On the high pressure V-Packing models or larger manifolds, it may be necessary to gently tap with a soft mallet until the manifold is flush with the crankcase.
6. Replace two (2) Lockwashers, two (2) Socket Head Screws or four (4) Flanged Nuts and torque per chart.

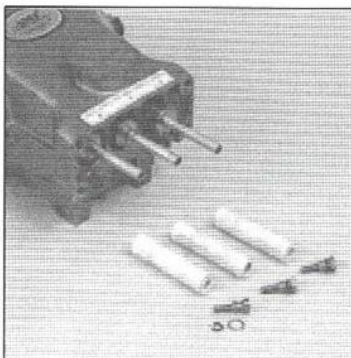

Ceramic Plunger and Retainer Arrangement

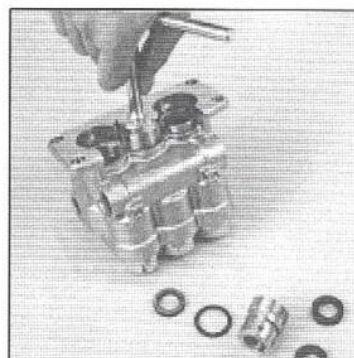

Removal of Seal Cases from Manifold Head

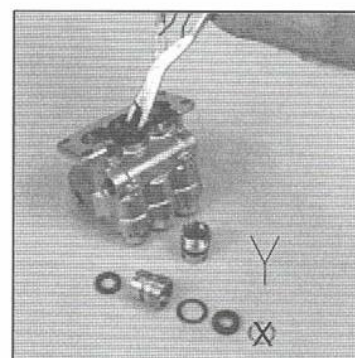

Removal of High Pressure Seals

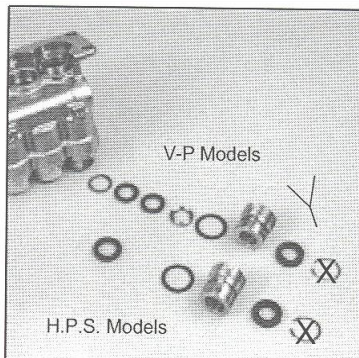

Seal and V-Packing Arrangement

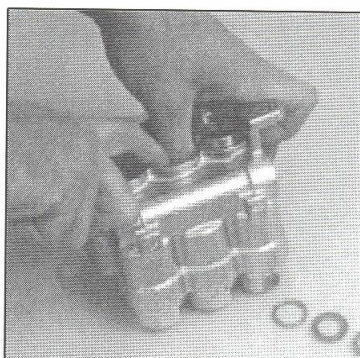

Installation of Male Adapter

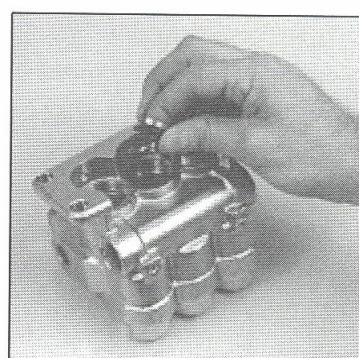

Order of Packings [MA, VP, FA]

SERVICING THE PLUNGERS

Disassembly

1. Remove the Manifold Head as described in the Servicing the Pumping Section.
2. To service the plungers, first remove the Oil Pan then the Seal Retainers with Wicks. The seal retainer is a two piece item that can easily be separated.
3. Using an M12 hex tool on the 5, 7 and 15 Frame pumps, or an M11 hex tool on the OEM 5, and 7 Frame pumps, loosen the Plunger Retainer about three to four turns. Push the Plunger back to separate it from the Retainer and finish unthreading the Plunger Retainer by hand.
4. Unthread the Plunger Retainer, O-Ring, Back-up-Ring and Gasket. Stud may stay on Plunger Rod or come off with Plunger Retainers.
5. Remove the Ceramic Plunger, Keyhole Washer and Barrier Slinger from Plunger Rod.

Reassembly

1. Visually inspect Crankcase Seal for deterioration or leaks and contact factory for assistance with replacement. Replace Barrier Slinger if damaged and slide onto Plunger Rod **with concave side away from crankcase**.
2. Examine Ceramic Plunger for scoring or cracks and replace if worn. **Ceramic Plunger can only be installed in one direction (front to back)**. Do not force onto rod.
3. Examine O-Ring and Back-up-Ring on Plunger Retainer and replace if cut or worn. Lubricate O-Ring for ease of installation and to avoid damage to the o-rings. **Install NEW Gasket, then O-Ring, then Back-up-Ring** onto Plunger Retainer.
NOTE: OEM models have a longer Stud for the Plunger Retainer.
4. Apply Loctite 242 to exposed threads of Stud and thread Plunger Retainer onto Plunger Rod. Torque per chart.
5. Install the two-piece Seal Retainer with NEW Wick onto each rod with **tab down and wick out**.
6. Proceed with servicing the seals or remounting of Manifold Head as described.

SERVICING THE SEALS AND V-PACKINGS

Disassembly

1. Remove the Manifold Head as described in Servicing the Pumping Section.
2. Place Manifold Head on work surface **with crankcase side up**.
3. On 5PFR and 7PFR plunger pumps prior to May of 1989, remove Snap Ring and Lo-Pressure Seal from each Seal Case. Discard Snap Rings (refer to Tech Bulletin 054).
4. On 5PFR and 7PFR plunger pumps after May of 1989, remove Lo-Pressure Seal from each Seal Case.
5. On 15PFR plunger pumps, remove Snap Ring and Lo-Pressure Seal from each Seal Case.
6. Remove Seal Case from each seal chamber. Remove O-Ring from outside diameter of Seal Case.
7. **Hi-Pressure Seal Models:** The Hi-Pressure Seal is generally easily removed from the manifold without any tools. If extremely worn a reverse pliers may be used (lower set of seals in photo).
8. **V-Packing Models:** The Female Adapter, V-Packings and Male Adapter are easily removed from manifold without tools. If extremely worn a reverse pliers may be used (upper set of seals in photo).

Reassembly

V-Packing Models:

1. Lubricate seal chamber in the manifold.
NOTE: For certain applications apply liquid gasket to the O-Ring crevices and seal surfaces. See Tech Bulletin #053 for model identification.
2. Insert Male Adapter **with notches down** and "v" side up and press completely into chamber by hand.
3. Lubricate V-Packings and install one at a time with **grooved side down**.
4. Install Female Adapter with **grooved side down**.
5. Examine Seal Case O-Ring and replace if worn. Lubricate new O-Rings before installing.
6. Thread Seal Case into manifold and tighten with special seal case tool. Torque per chart.

Reassembly

Hi-Pressure Seal Models:

1. Lubricate seal chamber in manifold.
NOTE: For certain applications apply liquid gasket to the o-ring crevices and seal surfaces. See Tech Bulletin #053 for model identification.
2. Carefully square Hi-Pressure Seal into position by hand with the **grooved side down** (metal back facing out).
3. Examine Seal Case O-Ring and replace if worn. Lubricate new O-Ring before installing.
4. Secure Hi-Pressure Seal into position by threading Seal Case into manifold. Tighten Seal Case with special seal case tool. Torque per chart.

Reassembly

Lo-Pressure Seal-All Models:

1. Examine Lo-Pressure Seals for wear or broken springs and replace if necessary.
2. Install Lo-Pressure Seal into each seal case with **garter spring down**.
3. On 5PFR and 7PFR plunger pumps **do not use** Snap Ring (refer to Tech Bulletin 054).
4. On 15PFR plunger pumps install Snap Ring into each Seal Case.
5. Install the two-piece Seal Retainer with new Wick onto each plunger rod **with tab down and wick out**.
6. Replace Manifold Head onto pump as described under servicing the pumping section and torque per chart.

SERVICING THE CRANKCASE SECTION

1. While manifold, plungers and seal retainers are removed, examine Crankcase Seals for wear.
2. Check oil level and for evidence of water in oil.
3. Rotate Crankshaft by hand to feel for smooth bearing movement.
4. Examine Crankshaft Oil Seals externally for drying, cracking or leaking.
5. Consult factory or your local distributor if crankcase service is evidenced.

See Section I of the Plunger Pump Service Video for additional information.

PREVENTATIVE MAINTENANCE CHECK-LIST

| Check | Daily | Weekly | 50 hrs. | 500 hrs.* | 1500 hrs.** | 3000 hrs.** |
|--------------------|-------|--------|---------|-----------|-------------|-------------|
| Clean Filters | x | | | | | |
| Oil Level/Quality | x | | | | | |
| Oil Leaks | x | | | | | |
| Water Leaks | x | | | | | |
| Belts, Pulley | | x | | | | |
| Plumbing | | x | | | | |
| Initial Oil Change | | | x | | | |
| Oil Change | | | | x | | |
| Seal Change | | | | | x | |
| Valve Change | | | | | | x |
| Accessories | | | | | x | |

* If other than CAT PUMPS special multi-viscosity ISO68 oil is used, change cycle should be every 300 hours.

** Each system's maintenance cycle will be exclusive. If system performance decreases, check immediately. If no wear at 1500 hours, check again at 2000 hours and each 500 hours until wear is observed. Valves typically require changing every other seal change.

Duty cycle, temperature, quality of pumped liquid and inlet feed conditions all effect the life of pump wear parts and service cycle.

** Remember to service the regulator/unloader at each seal servicing and check all system accessories and connections before resuming operation. Refer to Service Manual and video for additional assistance.

TECHNICAL BULLETIN REFERENCE CHART

| No. | Subject | Models |
|-----|--|---------------------------------|
| 003 | Power Unit Drive Packages | 3PFR - 68PFR, 10FR - 60FR |
| 024 | Lubrication of Lo-Pressure Seals | All Models |
| 027 | Spring Retainer | 5PFR, 7PFR, 15PFR |
| 032 | Shaft Extension and Manifold Port | 310, 317, 323, 530, 550 |
| 035 | Servicing Crankcase Section | 7PFR - 60PFR |
| 036 | Cylinder and Plunger Reference Chart | All Models |
| 043 | LPS and HPS Servicing | All Plunger Models |
| 045 | One-Piece S.S. Plunger Retainer w/Stud | 5PFR, 7PFR, 15PFR |
| 046 | Valve Plug with Coil Spring | 317, 347, 357, 1057 |
| 047 | Blind Bearing Shaft Cover | Gearbox Plunger Pumps |
| 048 | Extended Valve Plug | 7PFR and 15PFR |
| 049 | Stainless Steel Hardware | 3PFR7, 5PFR7, 15PFR7 |
| 051 | M10 Manifold and Crankcase | 7PFR and OEM |
| 052 | Plunger Rod and Stud | 3PFR, 5PFR, 15PFR, 35PFR, 60PFR |
| 053 | Liquid Gasket | All Plunger NAB-S.S. Models |
| 054 | 2 Piece Seal Retainer | 5PFR and 7PFR |
| 058 | Forged Manifold and Extended Valve Plugs | 56, 57, 59, 60 |
| 060 | Baffle Assembly | 34170 |
| 061 | Installation and Adjustment Procedure | 8100 |
| 062 | Manifold and Seal Case | 650 and 651 |
| 064 | By-Pass Hose Sizing | All Unloaders/Regulators |
| 067 | S.S. Plunger Retainer | 3PFR, 5PFR, 7PFR |
| 072 | Manifold Head and V-Packing | 1050, 1051, 1057 |
| 073 | Hi-Temp HPS | 3PFR, 5PFR, 2SF |
| 074 | Torque Chart | Piston and Plunger Pumps |
| 077 | Oil Drain Kit | All Models (except 2SF/4SF) |
| 083 | Winterizing a Pump | All Models |

| TORQUE CHART | | | | |
|---|----------|-------------------------|----------|-------------|
| Pump Item | Thread | Tool Size [P/N] | Torque | |
| Pump Model | | | in. lbs. | ft. lbs. Nm |
| PLUNGER RETAINER | | | | |
| OEM Models | M6 | M11 Hex [44044] | 55 | 4.4 6 |
| All Standard Models..... | M6 | M12 Hex | 55 | 4.4 6 |
| MANIFOLD HEAD BOLTS | | | | |
| 5PFR 31, 34, 35..... | M10 | M8 Allen [25052] | 220 | 18.1 25 |
| 310, 340, 350 | | | | |
| 311, 341, 351 | | | | |
| 317, 347, 357 | | | | |
| 5PFR 42HS, 43HS, 45..... | M10 | M8 Allen [33046] | 220 | 18.1 25 |
| 7PFR 510, 530, 550..... | M10 | M14 Hex [25053] | 220 | 18.1 25 |
| 56, 57, 58, 59, 60, 70 | | | | |
| 15PFR 650, 651, 660, 661..... | M10 | M17 Hex [25083] | 220 | 18.1 25 |
| 1050, 1051, 1057 | | | | |
| VALVE PLUGS | | | | |
| 5PFR 31, 34, 35..... | M22 | M24 Hex [44046] | 870 | 72.3 98 |
| 310, 311, 317 | | | | |
| 340, 341, 347 | | | | |
| 350, 351, 357 | | | | |
| 42HS | | | | |
| 5PFR 43HS, 45..... | M25 | M24 Hex [44046] | 520 | 43.4 59 |
| 7PFR 530, 550..... | 3/4" SPT | M27 Hex [44045] | 870 | 72.3 98 |
| 51, 55, 56, 57, 58 | | | | |
| 59, 60, 70 | | | | |
| 15PFR 650, 651, 660, 661..... | 3/4" SPT | M27 Hex [44045] | 870 | 72.3 98 |
| 1050, 1051, 1057 | | | | |
| CRANKCASE COVER/BEARING COVER SCREWS | | | | |
| 5PFR 31, 34, 35..... | M6 | M10 Hex/Phil. [25082] | 50 | 4.0 6 |
| 310, 340, 350 | | | | |
| 317, 347, 357 | | | | |
| 311, 341, 351 | | | | |
| 5PFR 42HS, 43HS, 45..... | M6 | M10 Hex/Phil. [25082] | 50 | 4.0 6 |
| | M8 | M13 Hex [25324] | 115 | 9.4 13 |
| 7PFR 51, 53, 55, 56, 57..... | M6 | M10 Hex [25082] | 115 | 9.4 13 |
| 59, 60, 70 | | | | |
| 15PFR 650, 1050..... | M6 | M10 Hex [25082] | 50 | 4.0 5.7 |
| 1051, 1057..... | N/A | 1/2" Soc. Drive [33004] | 354 | 29.5 40 |
| 5PFR 31, 34, 35..... | N/A | 1/2" Soc. Drive [33005] | 354 | 29.5 40 |
| 310, 311, 317 | | | | |
| 340, 341, 347 | | | | |
| 350, 351, 357 | | | | |
| 42HS, 43HS, 45..... | N/A | 1/2" Soc. Drive [33005] | 354 | 29.5 40 |
| 7PFR 51, 53, 55, 56,..... | N/A | 1/2" Soc. Drive [33005] | 354 | 29.5 40 |
| 57, 58, 59, 60, 70 | | | | |
| 530, 550 | | | | |
| 15PFR 650, 651, 660, 661..... | N/A | 1/2" Soc. Drive [33006] | 346 | 28.8 39 |
| 1050, 1051, 1057..... | N/A | 1/2" Soc. Drive [33006] | 390 | 32.5 44 |
| SEAL CASE | | | | |
| BUBBLE OIL GAUGE | | | | |
| All Models..... | M28 | Oil Gauge Tool [44050] | 45 | 3.6 5 |
| MOUNTING BOLTS | | | | |
| 5PFR, 7PFR..... | M8 | M13 Hex [25324] | 115 | 9.4 13 |
| 15PFR..... | M10 | M17 Hex [25083] | 240 | 19.7 29 |

INLET CONDITION CHECK-LIST

Review Before Start-Up

Inadequate inlet conditions can cause serious malfunctions in the best designed pump. Surprisingly, the simplest of things can cause the most severe problems or go unnoticed to the unfamiliar or untrained eye. REVIEW THIS CHECK-LIST BEFORE OPERATION OF ANY SYSTEM. Remember, no two systems are alike, so there can be no ONE best way to set-up a system. All factors must be carefully considered.

INLET SUPPLY should exceed the maximum flow being delivered by the pump to assure proper performance.

- Open inlet shut-off valve and turn on water supply to avoid starving the pump. **DO NOT RUN PUMP DRY.**
- Avoid closed loop systems especially with high temperature, ultra-high pressure or large volumes. Conditions vary with regulating/unloader valve.
- Low vapor pressure liquids, such as solvents, require a booster pump and C.A.T. to maintain adequate inlet supply.
- Higher viscosity liquids require a positive head and a C.A.T. to assure adequate inlet supply.
- Higher temperature liquids tend to vaporize and require positive heads and C.A.T. to assure adequate inlet supply.
- When using an inlet supply reservoir, size it to provide adequate liquids to accommodate the maximum output of the pump, generally a minimum of 6-10 times the GPM (however, a combination of system factors can change this requirement); provide adequate baffling in the tank to eliminate air bubbles and turbulence; install diffusers on all return lines to the tank.

INLET LINE SIZE should be adequate to avoid starving the pump.

- Line size must be a minimum of one size larger than the pump inlet fitting. Avoid tees, 90 degree elbows or valves in the inlet line of the pump to reduce the risk of flow restriction and cavitation.
- The line **MUST** be a FLEXIBLE hose, NOT a rigid pipe, and reinforced on SUCTION systems to avoid collapsing.
- The simpler the inlet plumbing the less the potential for problems. Keep the length to a minimum, the number of elbows and joints to a minimum (ideally no elbows) and the inlet accessories to a minimum.
- Use pipe sealant to assure air-tight, positive sealing pipe joints.

INLET PRESSURE should fall within the specifications of the pump.

- Acceleration loss of liquids may be increased by high RPM, high temperatures, low vapor pressures or high viscosity and may require pressurized inlet and C.A.T. to maintain adequate inlet supply. **DO NOT USE C.A.T. WITH SUCTION INLET.**
- Optimum pump performance is obtained with +20 PSI (1.4 BAR) inlet pressure and a C.A.T. for certain applications. With adequate inlet plumbing, most pumps will perform with flooded suction. Maximum inlet pressure is 60 PSI (4 BAR).
- After prolonged storage, pump should be rotated by hand and purged of air to facilitate priming. Disconnect the discharge port and allow liquid to pass through pump and measure flow.

INLET ACCESSORIES are designed to protect against overpressurization, control inlet flow, contamination or temperature and provide ease of servicing.

- A shut-off valve is recommended to facilitate maintenance.
- Installation of a C.A.T. is essential in applications with stressful conditions such as high temperatures, booster pump feed or long inlet lines. **Do not use C.A.T. with negative inlet pressure.**
- A stand pipe can be used in some applications to help maintain a positive head at the pump inlet.
- Inspect and clean inlet filters on a regular schedule to avoid flow restriction.
- A pressure transducer is necessary to accurately read inlet pressure. (**Short term, intermittent cavitation will not register on a standard gauge.**)
- All accessories should be sized to avoid restricting the inlet flow.
- All accessories should be compatible with the solution being pumped to prevent premature failure or malfunction.
- Optional inlet protection can be achieved by installing a pressure cutoff switch between the inlet filter and the pump to shut off pump when there is no positive inlet pressure.

BY-PASS TO INLET Care should be exercised when deciding the method of by-pass from control valves.

- It is recommended the by-pass be directed to a baffled reservoir tank, with at least one baffle between the by-pass line and the inlet line to the pump.
- Although not recommended, by-pass liquid may be returned to the inlet line of the pump if the system is properly designed to protect your pump. A PRESSURE REDUCING VALVE must be installed on the inlet line (**BETWEEN THE BY-PASS CONNECTION AND THE INLET TO THE PUMP**) to avoid excessive pressure to the inlet of the pump. It is also recommended that a THERMO VALVE be used in the by-pass line to monitor the temperature build-up in the by-pass loop to avoid premature seal failure.
- A low-pressure, flexible cloth braid (not metal braid) hose should be used from the by-pass connection to the inlet of the pump.
- Caution should be exercised not to undersize the by-pass hose diameter and length. Refer to Technical Bulletin 64 for additional information on the size and length of the by-pass line.
- Check the pressure in the by-pass line to avoid overpressurizing the inlet.
- The by-pass line should be connected to the pump inlet line at a gentle angle of 45° or less and no closer than 10 times the pump inlet port diameter e.g. 1-1/2" port size = 15" distance from pump inlet port.

| HOSE FRICTION LOSS | | | | | | | |
|---------------------------|--|------|------|-----|-----|-----|----|
| Water* Flow Gal/Min | PRESSURE DROP IN PSI PER 100 FT OF HOSE WITH TYPICAL WATER FLOW RATES | | | | | | |
| | Hose Inside Diameters, Inches | | | | | | |
| | 1/4 | 5/16 | 3/8 | 1/2 | 5/8 | 3/4 | 1" |
| 0.5 | 16 | 5 | 2 | | | | |
| 1 | 54 | 20 | 7 | 2 | | | |
| 2 | 180 | 60 | 25 | 6 | 2 | | |
| 3 | 380 | 120 | 50 | 13 | 4 | 2 | |
| 4 | | 220 | 90 | 24 | 7 | 3 | |
| 5 | | 320 | 100 | 34 | 10 | 4 | |
| 6 | | | 220 | 52 | 16 | 7 | 1 |
| 8 | | | 300 | 80 | 25 | 10 | 2 |
| 10 | | | 450 | 120 | 38 | 14 | 3 |
| 15 | | | 900 | 250 | 80 | 30 | 7 |
| 20 | | | 1600 | 400 | 121 | 50 | 12 |
| 25 | | | | 550 | 200 | 76 | 19 |
| 30 | | | | | 250 | 96 | 24 |
| 40 | | | | | 410 | 162 | 42 |
| 50 | | | | | 600 | 235 | 62 |
| 60 | | | | | | 370 | 93 |

*At a fixed flow rate with a given size hose, the pressure drop across a given hose length will be directly proportional. A 50 ft. hose will exhibit one-half the pressure drop of a 100 ft. hose. Above values shown are valid at all pressure levels.

| WATER LINE PRESSURE LOSS | | | | | | | | | | | | | | | |
|-----------------------------------|-------------------------|-----|-----|-----|-----|-------------------------|-------|-------|-----|-------|---------------------------|-------|-----|-----|-----|
| PRESSURE DROP IN PSI PER 100 FEET | | | | | | | | | | | | | | | |
| Water GPM | Steel Pipe—Nominal Dia. | | | | | Brass Pipe—Nominal Dia. | | | | | Copper Tubing O.D. Type L | | | | |
| | 1/4 | 3/8 | 1/2 | 3/4 | 1 | 1 1/4 | 1 1/2 | 1 3/4 | 2 | 2 1/2 | 3 | 3 1/2 | 4 | | |
| 1 | 8.5 | 1.3 | | | | 6.0 | 1.0 | | | | 120 | 13 | 2.9 | 1.0 | |
| 2 | 30 | 7.0 | 2.1 | | | 20 | 3.6 | 1.8 | | | 400 | 45 | 10 | 3.8 | 1.3 |
| 3 | 60 | 14 | 4.5 | 1.1 | | 48 | 11 | 3.8 | | | 84 | 20 | 6.7 | 2.6 | |
| 5 | 150 | 38 | 12 | 2.8 | | 100 | 28 | 9.0 | 2.2 | | 200 | 50 | 17 | 8.1 | 3.0 |
| 8 | 330 | 86 | 28 | 6.7 | 1.9 | 200 | 62 | 21 | 6.2 | 1.6 | 550 | 100 | 40 | 15 | 5.5 |
| 10 | 520 | 130 | 43 | 10 | 3.0 | 320 | 90 | 30 | 7.8 | 2.4 | | 180 | 55 | 22 | 10 |
| 15 | 270 | 80 | 21 | 6.2 | 1.8 | | 180 | 52 | 16 | 5.0 | 1.5 | | 120 | 44 | 20 |
| 25 | 870 | 240 | 50 | 16 | 4.2 | 2.0 | 470 | 150 | 40 | 12 | 3.8 | 1.2 | 330 | 110 | 50 |
| 40 | | 66 | 17 | 4.0 | | | | | 39 | 11 | 5.0 | | 580 | 200 | 85 |
| 60 | | | 37 | 17 | | | | | | | 23 | 11 | | | |
| 80 | | | 62 | 20 | | | | | | | 48 | 19 | | | |
| 100 | | | 210 | 107 | 48 | | | | | | 67 | 28 | | | |

| RESISTANCE OF VALVES AND FITTINGS | | | | | | | | | | |
|------------------------------------|------------------------------|--|----------------|----------------|--------------|--------------|----------------------|--------------------|-----------------------|--|
| Nominal Pipe Size, Inches | Inside Diameter Inches | Equivalent Length of Standard Pipe in Feet | | | | | | | | |
| | | Gate Valve | Globe Valve | Angle Valve | 45° Elbow | 90° Elbow | 180° Close Fit | Tee Thru Run | Tee Thru Branch | |
| 1/2 | 0.622 | 0.41 | 18.5 | 9.3 | 0.78 | 1.67 | 3.71 | 0.93 | 3.33 | |
| 3/4 | 0.874 | 0.54 | 24.5 | 12.3 | 1.03 | 2.21 | 4.90 | 1.23 | 4.41 | |
| 1 | 1.043 | 0.69 | 31.2 | 15.6 | 1.31 | 2.81 | 6.25 | 1.56 | 5.62 | |
| 1 1/4 | 1.380 | 0.93 | 41.0 | 20.5 | 1.73 | 3.78 | 8.22 | 2.05 | 7.40 | |
| 1 1/2 | 1.619 | 1.05 | 48.0 | 24.0 | 2.15 | 4.31 | 9.59 | 2.40 | 8.63 | |
| 2 | 2.067 | 1.35 | 61.5 | 30.8 | 2.59 | 5.55 | 12.30 | 3.08 | 11.60 | |
| 2 1/2 | 2.469 | 1.62 | 73.5 | 36.8 | 3.09 | 6.61 | 14.10 | 3.68 | 13.20 | |
| 3 | 3.068 | 2.01 | 91.5 | 45.8 | 3.84 | 8.23 | 18.20 | 4.67 | 16.40 | |
| 4 | 4.026 | 2.64 | 120.0 | 60.0 | 5.03 | 10.80 | 23.90 | 6.00 | 21.60 | |

Arriving at a total line pressure loss, consideration should then be given to pressure loss created by valves, fittings and elevation of lines.
If a sufficient number of valves and fittings are incorporated in the system to materially affect the total line loss, add to the total line length, the equivalent length of line of each valve or fitting.

**TYPICAL RESERVOIR TANK
RECOMMENDED 6 TO 10 TIMES SYSTEM CAPACITY**

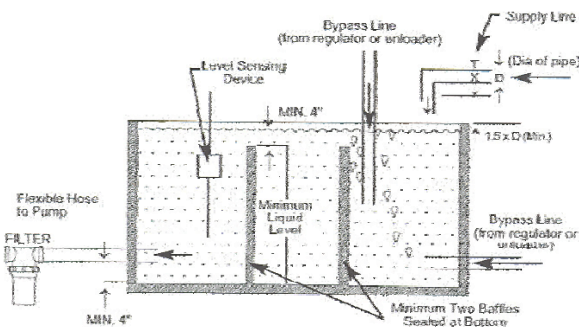

Handy Formulas to Help You

Q. How can I find the RPM needed to get specific GPM (Gallons Per Minute) I want?

A. Desired RPM = $\frac{\text{Desired GPM} \times \text{Rated RPM}}{\text{Rated GPM}}$

Q. I have to run my pump at a certain RPM. How do I figure the GPM I'll get?

A. Desired GPM = $\frac{\text{Desired RPM} \times \text{Rated GPM}}{\text{Rated RPM}}$

Q. Is there a simple way to find the approximate horsepower I'll need to run the pump?

A. Electric Brake Horsepower Required = $\frac{\text{GPM} \times \text{PSI}}{1460}$ (Standard 85% Mech. Efficiency)

Q. What size motor pulley should I use?

A. $\frac{\text{Pump Pulley (Outer Diameter)} \times \text{Pump RPM}}{\text{Motor/Engine RPM}}$ (Consult Engine Mfr.)

Q. How do I calculate the torque for my hydraulic drive system?

A. Torque (ft. lbs.) = $3.6 \left(\frac{\text{GPM} \times \text{PSI}}{\text{RPM}} \right)$

Avoid Cavitation Damage

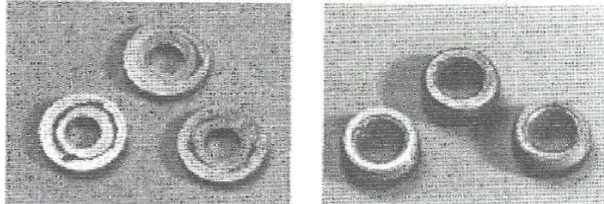

One or several of the conditions shown in the chart below may contribute to cavitation in a system resulting in premature wear, system downtime and unnecessary operating costs.

| CONDITION | SOLUTION |
|--|--|
| Inadequate inlet line size: | • Increase line size to the inlet port or one size larger |
| Water hammering liquid acceleration/deacceleration | • Install C.A.T. Tube • Move pump closer to liquid supply |
| Rigid Inlet Plumbing | • Use flexible wire reinforced hose to absorb pulsation and pressure spikes |
| Excessive Elbows in Inlet Plumbing | • Keep elbows to a minimum and less than 90° |
| Excessive liquid Temperature | • Use Thermo Valve in bypass line • Do not exceed pump temperature specifications • Substitute closed loop with baffled holding tank • Adequately size tank for frequent or high volume bypass • Pressure feed high temperature liquids • Properly ventilate cabinets and rooms |
| Air Leaks in Plumbing | • Check all connections • Use Teflon tape |
| Agitation in Supply Tank | • Size tank according to pump output • Minimum 6-10 times system GPM • Baffle tank to purge air from liquid and separate inlet from discharge |
| High Viscosity Liquids | • Verify viscosity against pump specifications before operation • Elevate liquid temperature enough to reduce viscosity • Lower RPM of pump • Pressure feed pump • Increase inlet line size |
| Clogged Filters | • Perform regular maintenance or use clean filters to monitor build up • Use adequate mesh size for liquid and pump specifications |

DIAGNOSIS AND MAINTENANCE

| PROBLEM | PROBABLE CAUSE | SOLUTION |
|--|---|--|
| Low Pressure | <ul style="list-style-type: none"> Worn nozzle Belt slippage Air leak in inlet plumbing Pressure gauge inoperative or not registering accurately Relief valve stuck partially plugged or improperly adjusted Worn seat or valves Inlet suction strainer clogged or improperly sized Worn seals. Abrasives in pumped liquid, severe cavitation; inadequate water supply, stressful inlet conditions Fouled or dirty inlet or discharge valves Worn inlet or discharge valves Leaky discharge hose | <ul style="list-style-type: none"> Replace nozzle of proper size. Tighten or replace; use correct belt. Use PTFE liquid or tape. Check pressure with new gauge and replace as needed. Clean and reset relief valve to system pressure and correct by-pass. Check supply tank for contamination. Clean or replace with Valve Kit. Use adequate size for inlet pump connection and liquid being pumped. Clean frequently. Install and maintain proper filter, check line size and flow available to pump. Install a C.A.T. Clean inlet and discharge valve assemblies. Replace with Valve Kit. Replace hose. Check connections. |
| Pulsation, pump runs extremely rough, pressure low | <ul style="list-style-type: none"> Faulty Pulsation Dampener Restricted inlet or air entering inlet plumbing Stuck inlet or discharge valve | <ul style="list-style-type: none"> Check precharge of system pressure or replace as needed. Check filters and clean as needed. Check fittings and use PTFE liquid or tape for airtight connection. Clean or replace valve. Check supply tank for contamination. |
| Water leakage from under the manifold *Slight leakage | <ul style="list-style-type: none"> Worn Lo-Pressure, Hi-Pressure Seals or V Packings | <ul style="list-style-type: none"> Replace with Seal Kit, check inlet pressure and system temperature, use Thermo Valve in by-pass line; inlet pressure regulator in inlet line. |
| Oil leak between crankcase and pumping section | <ul style="list-style-type: none"> Worn crankcase seals | <ul style="list-style-type: none"> Replace crankcase seals. |
| Oil leaking in the area of crankshaft | <ul style="list-style-type: none"> Worn crankshaft seal Bad bearing | <ul style="list-style-type: none"> Replace damaged seals. Replace bearing. |
| Excessive play in the end of the crankshaft | <ul style="list-style-type: none"> Worn bearing | <ul style="list-style-type: none"> Replace bearing. |
| Water in crankcase | <ul style="list-style-type: none"> Humid air condensing into water inside the crankcase Worn and leaking Lo-Pressure Seals and V-Packing. Operating beyond normal service cycle. Leaking crankcase seals or seals installed backward | <ul style="list-style-type: none"> Change oil every 3 months or 500 hour intervals using special CAT PUMPS Premium Grade Oil, PN 6100 (Case) 6107 (Bottle), (other approved oil every month or 300 hours). Repair with Seal Kit. Initiate more frequent service cycle. Replace seals. Follow proper installation procedure. Contact CAT PUMPS supplier for crankcase servicing. |
| Oil leaking at the rear portion of the crankcase | <ul style="list-style-type: none"> Damaged or improperly installed oil gauge, crankcase cover or drain plug O-ring | <ul style="list-style-type: none"> Replace oil gauge, crankcase cover or drain plug O-ring. Thread in oil gauge and drain plug hand tight to avoid extruding O-ring. |
| Loud knocking noise in pump | <ul style="list-style-type: none"> Pulley loose on crankshaft Worn bearing, connecting rod or crankshaft Stressful inlet conditions | <ul style="list-style-type: none"> Check key and tighten set screw. Consult CAT PUMPS supplier for crankcase servicing. Install C.A.T. |
| Frequent or premature failure of the packing | <ul style="list-style-type: none"> Scored plungers Over pressure to inlet manifold Abrasive material in the liquid being pumped Excessive pressure and/or temperature of liquid being pumped Running pump dry | <ul style="list-style-type: none"> Replace plungers. Reduce inlet pressure per instructions. Install proper filtration on pump inlet plumbing. Check pressure and inlet liquid temperature. Be sure they are within specified range. DO NOT RUN PUMP WITHOUT LIQUID. |
| Strong surging at the inlet and low pressure | <ul style="list-style-type: none"> Foreign particles in the inlet or discharge valve or worn inlet and/or discharge valves | <ul style="list-style-type: none"> Check for smooth surfaces on inlet and discharge valve seats. Replace with kit if pitted or worn. Check supply tank for contamination. Install and regularly clean filter. Do not pump abrasive liquids. |

INSTRUCTIONS FOR INSTALLING Watts Water Pressure Reducing Valves



INSTALL THE VALVE IN THE LINE WITH THE SUPPLY CONNECTED TO VALVE INLET (MARKED "IN" ON CASTING) OR WITH THE ARROW ON THE VALVE BODY POINTING IN THE DIRECTION OF FLOW.

These regulators can be installed horizontally in either an upright or inverted position, as shown or vertically and is a matter of choice of accessibility for servicing the regulator. For example, in an upright position (Figure A) the strainer area, on valves so equipped, can more easily be cleaned out by removing the bottom plug and any collected sediment will fall downwards. Accessibility for servicing the regulator section, however, may be less convenient.

When the valve is installed in an inverted position (Figure B), the "regulator section" is more readily exposed for simplified servicing of the disc and seat, while the strainer can almost as easily be flushed out by turning the water supply on slightly.

NOTE: Regulator must always be installed in an accessible location to facilitate servicing.

For household use install the reducing valve, when possible so that the sill cock line is after or downstream of the reducing valve as shown in diagram below. Before installing the reducing valve flush out the line to remove loose dirt and scale which might damage valve disc and seat. On valves having strainers the screen should be removed and cleaned at least once every six months, more often if water conditions are bad.

TO READJUST reduced pressures, loosen check nut and turn adjusting screw clockwise to raise reduced pressure and counter clockwise to lower reduced pressure.

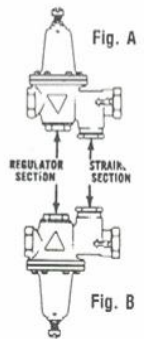

When a reducing valve is used it makes a closed system; therefore, pressure relief protection must be provided on the downstream side of the regulator to protect equipment.

