

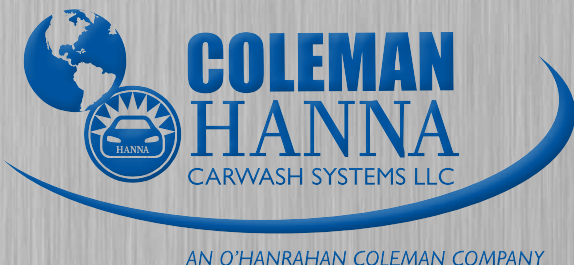

Focus Flex Wrap

Service Manual



5842 W 34th St, Houston, TX 77092
1.800.999.9878 • 1.713.683.9878
www.colemanhanna.com



Find us on Facebook:
[/ColemanHannaCarwash](https://www.facebook.com/ColemanHannaCarwash)

Table of Contents

- 1.0 INSTALLATION..... 1-1**
 - 1.0 Before Installation1-1
 - 1.1 Setup.....1-2
 - 1.2 Structure Installation1-3
 - 1.2.1 Box and Shaft Installation1-6
 - 1.2.2 Core Assembly Installation.....1-8
 - 1.2.3 Bumper Stop Installation1-10
 - 1.2.4 Shock and Cylinder Installation1-12
 - 1.2.5 Leveling the Arms1-13
 - 1.3 Pneumatic Connections1-14
 - 1.4 Water Connections.....1-21
 - 1.5 Hydraulic Connections1-22
 - 1.6 Pneumatic Control Box Electrical Connections1-23
 - 1.7 Other Electrical Connections.....1-25
 - 1.8 Startup.....1-25
 - 1.9 Installation Check List1-27
 - 1.10 Hydraulic Tubing Color Code1-28

- 2.0 SAFETY..... 2-1**
 - 2.1 Cautions, Warnings, and Notes2-2

Table of Figures

Figure 1-1	The Hanna Focus Wrap Isometric Layout	1-1
Figure 1-2	Header Assembly Bolted to Legs.....	1-2
Figure 1-3	Mounted Post-to-Header Gusset	1-2
Figure 1-4	Plumb Bob	1-3
Figure 1-5	Centerline Orientation of the Hanna Focus Wrap.....	1-3
Figure 1-6	Spatial Orientation of the Hanna Focus Wrap.....	1-4
Figure 1-7	Anchor Bolt	1-4
Figure 1-8	Bearing Attached to the End of the Arm Weldment.....	1-4
Figure 1-9	Top View of the Box and Shaft Assembly.....	1-5
Figure 1-10	Box and Shaft Assembly Connected to the Arm Weldment	1-1
Figure 1-11	Taper Lock on Shaft	1-3
Figure 1-12	4-Bolt Flange for Lower Core	1-4
Figure 1-13	Core Assembly Orientation Over the Shaft	1-4
Figure 1-14	Focus Wrap in Retracted Position	1-4
Figure 1-15	Focus Wrap in Extended Position.....	1-5
Figure 1-16	Shock and Cylinder Assembly.....	1-5
Figure 1-17	Where to Make Adjustments for Arm Leveling.....	1-6
Figure 1-18	Pneumatic Cylinder Assembly.....	1-6
Figure 1-19	Pneumatic Flow Adjustment	1-7
Figure 1-20	Pneumatic Control Box for the Hanna Focus Flex Wrap	1-7
Figure 1-21	Right Hand Side of the Opened Control Box.....	1-8
Figure 1-22	Left Hand Side of the Opened Control Box	1-8
Figure 1-23	Extend and Retract Ports on the Control Box	1-9
Figure 1-24	Regulator Gauge.....	1-10
Figure 1-25	Filter Regulator.....	1-11
Figure 1-26	Close-up of the Regulator Gauge	1-2
Figure 1-27	Outside Edge of the Control Box	1-3
Figure 1-28	Water Manifold	1-3
Figure 1-29	Motors and Flow Direction used for Brush Rotation on the Focus Wrap.....	1-3
Figure 1-30	Tightening the Triple-Loc Fitting	1-4
Figure 1-31	Terminal Block Assembly Inside the Control Box.....	1-4
Figure 1-32	Brush Rotation of the Focus Flex Wrap	1-5
Figure 1-33	Hydraulic Color Coding	1-5

1.0 Before Installation

The following information is a recommended means for installation of the Hanna Focus Wrap. Check for the local utilities, making sure of proper access location and supply sizing. If anything must be changed, do so prior to the day of installation. Deficiencies discovered at the time of installation will greatly increase time spent before startup.

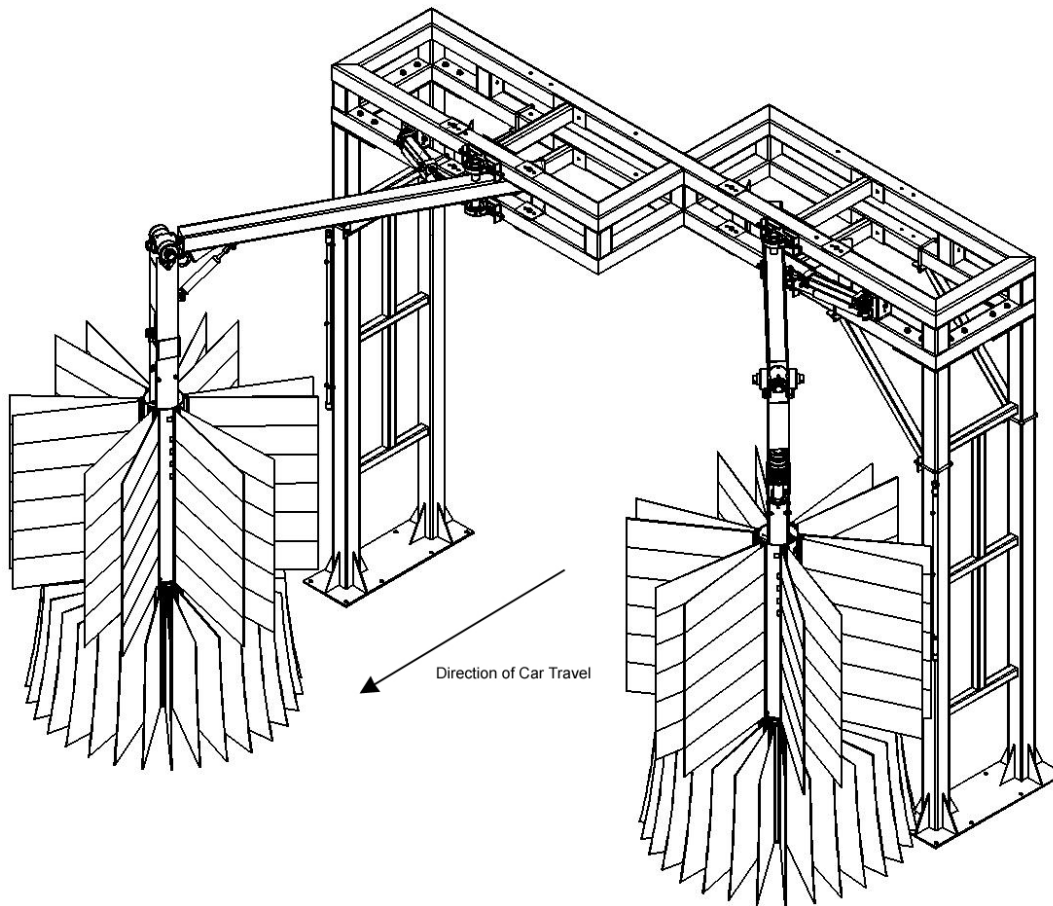

Figure 1-1. The Hanna Focus Wrap Isometric Layout

1.1 Setup

This section goes over the required tools, product checks, and safety precautions needed to continue on to the installation of the product.

1. Read this manual prior to opening crates or installing equipment.
2. Carefully open crates and identify the individual parts for assembly using the enclosed checklist. If there are any missing parts, notify your Hanna distributor immediately.



**WARNING: IF USING A FORKLIFT TO INSTALL EQUIPMENT
MAKE SURE TO FOLLOW OSHA AND GENERAL SAFETY
RULES AND REGULATIONS TO ENSURE PERSONAL SAFETY.**

3. Place the framework in the wash bay as shown on the layout drawing (available if purchased with system). Make sure the framework is facing the correct direction for vehicle travel. When all pieces for your configuration have been set in place, take the time to recheck the packing lists.
4. Make sure all of the necessary tools are on-hand before work is begun.
 - ✓ Set of ratchets/wrenches to secure bolts, nuts, connections, anchors, etc.
 - ✓ A rotary hammer to drill holes for the anchor bolts.
 - ✓ Large hammer to insert the anchor bolts to the ground.
 - ✓ A power grinder to remove excess material from the anchor bolts.
 - ✓ Tube cutters for poly connections.
 - ✓ Blade/box cutter.
 - ✓ Leveling tool to assure that the structure is accurately square.
 - ✓ Set of screwdrivers, as a flat head will be needed for the core assembly.
 - ✓ Tape measure to acquire proper distances and identifying marks.
 - ✓ Plumb bob to align the component to the centerline of the tunnel.
 - ✓ Teflon tape for fittings.
 - ✓ Never-seize for stainless steel hardware attachment.
 - ✓ Forklifts for heavy material.

1.2 Structure Installation

5. Stand the two legs where the correct location for the structure resides, do not anchor the legs into the ground at this time.
6. Carefully raise the header assembly on top of the legs using a forklift. It is recommended that one person on each side hold the legs while header is placed on top.
Note: Before bolting the structure in place, it is imperative that never-seize be placed on all stainless steel bolt threads to prevent locking.
7. Once aligned, use the $\frac{1}{2}$ " X $5 \frac{1}{2}$ " bolts, $\frac{1}{2}$ " flat washers, and $\frac{1}{2}$ " esna nuts to secure the header assembly to the legs. **Note:** When bolting the header to the legs make sure the head of the bolt is always on top of the structure and the washer and nut connect at the bottom. This will assure that the bolts will not fall if any nut should ever become disconnected.



Figure 1-2. Header Assembly Bolted to Legs

8. Place the post-to-header gussets on the structure. All post-to-header gussets are mounted parallel with the header assembly facing the inside legs of the structure. Once aligned, use the provided $5 \frac{1}{2}$ " U-bolts, $\frac{1}{2}$ " flat washers, and $\frac{1}{2}$ " esna nuts to secure all (4) of the gussets. (2) U-bolts will be required for every gusset.



Figure 1-3. Mounted Post-to-Header Gusset

9. Situate the structure so that it's perfectly over centerline of the carwash. The centerline is 26 ½" from the inside guiderail toward the passenger side (also drawn on the M1 equipment layout). Use the plumb bob and hang it from the center point of the Focus Wrap Header. When centered correctly, the tip of the plum bob will point to the centerline of the tunnel.



Figure 1-4. Plumb Bob

10. Using your level, make sure that the header assembly is level side-to-side and front-to-back. To compensate for any unevenness in the header, the installer may have to place spacer plates under the base plate of the offset leg.
11. Double check for accuracy before anchoring the base plates. If centered correctly, there will be **77 inches** from the outer edge of each base plate to the centerline.

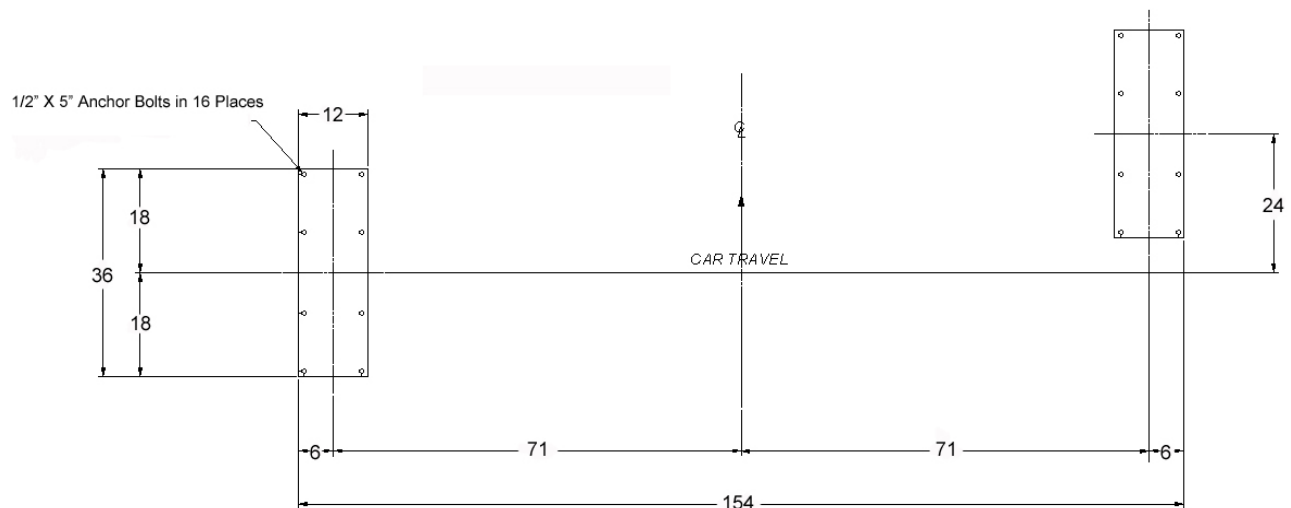

Figure 1-5. Centerline Orientation of the Hanna Focus Wrap

12. Refer to the drawings included in the manual and/or Equipment Layout to get full spatial requirements of the Hanna Focus Flex Wrap.

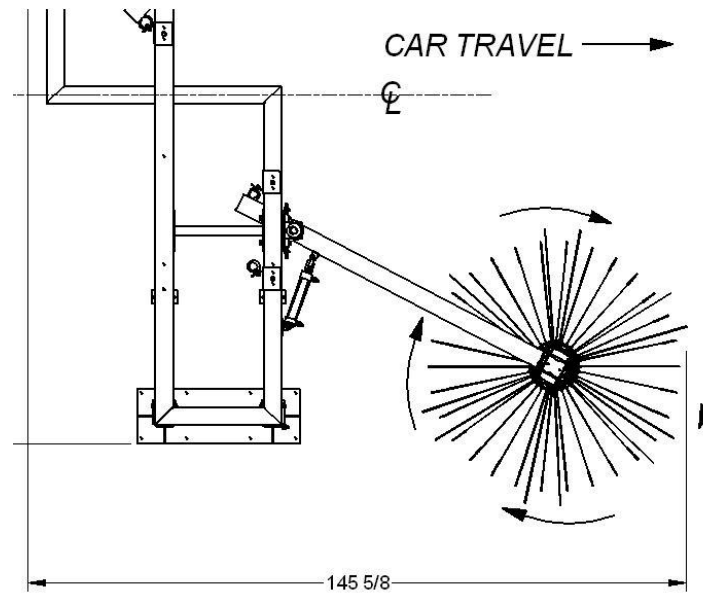

Figure 1-6. Spatial Orientation of the Hanna Focus Wrap

13. Once positioned, drill the pilot holes for the anchor bolts, drive the $\frac{1}{2}$ " X 5" anchor bolts into the ground, tighten the nuts, and grind off the excess threads flush with the anchor nut.



Figure 1-7. Anchor Bolt

14. Re-check and make sure that all bolts are completely tight after the structure has been moved and anchored down. Also recheck for levelness at this point.

1.2.1 Installing the Box and Shaft/Brush Assembly to the Arm Weldment

15. Raise the Box and Shaft assembly and slip bearings on the shaft with grease zerks facing up.

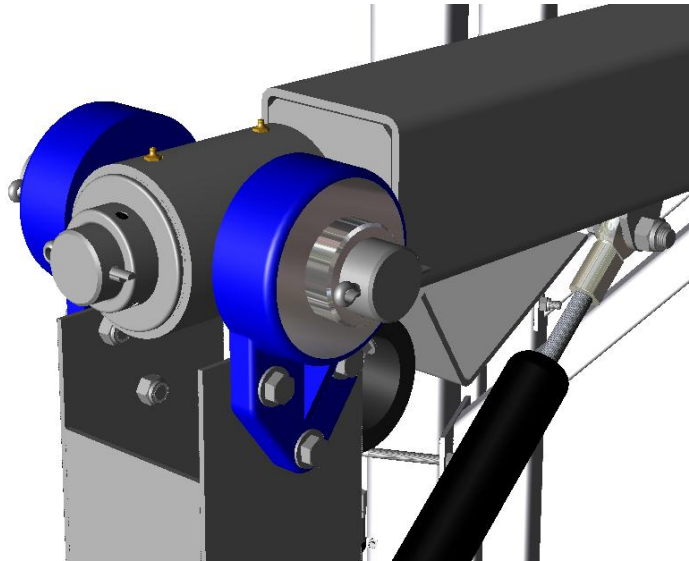

Figure 1-8. *Bearing Attached to the End of the Arm Weldment*

16. Once in place, tighten set collars are secure on the bearings.

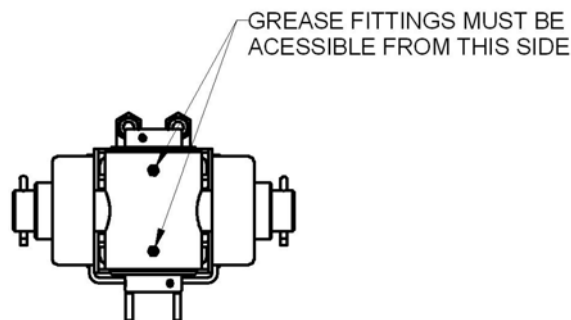

Figure 1-9. *Top View of the Box and Shaft Assembly*

17. Attach the shock assembly from the arm weldment to the box and shaft assembly. Make sure that the hardware connecting these items are free enough to rotate.
18. Tighten the set collars to prevent the bearing insert from slipping.

19. Make sure the three cotter pins provided at the end of the arm weldment are installed to complete the attachment of the Box and Shaft assembly.

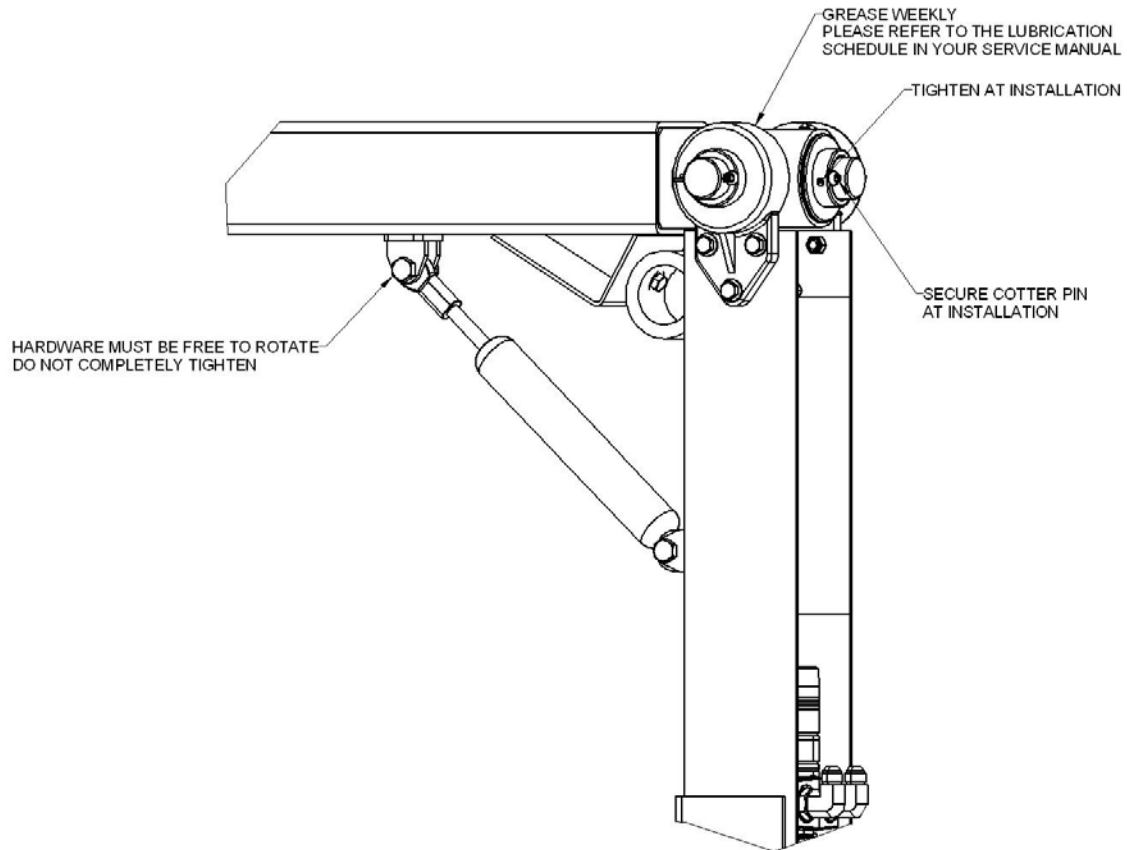

Figure 1-10. *Box and Shaft Assembly Connected to the Arm Weldment*

1.2.2 Installing the Core Assemblies to the Box and Shaft Assembly

20. Locate the (2) Box and Shaft assemblies provided with the equipment and gently lay them on a clear/dry working area.
21. Locate the (2) 48" X 8" Cores and the (2) 28" X 10" Cores. Locate the spider hub assemblies, split hub assemblies, and flange-bushing kits.
22. Install the spider just under the lowest bearing. Slip the upper core over the shaft and the spider. Then install the split hub and push it up as far as it will go. Secure both hub and core with a tie-down strap or rope.
23. Install the four-bolt flange onto the shaft. Then use a screwdriver to spread the taper lock slightly and slip the assembly up the shaft. The bottom of the lower core should be **12" off the ground on the conveyor side and 10" on the other side**. Set the four-bolt flange to achieve this height off the floor.

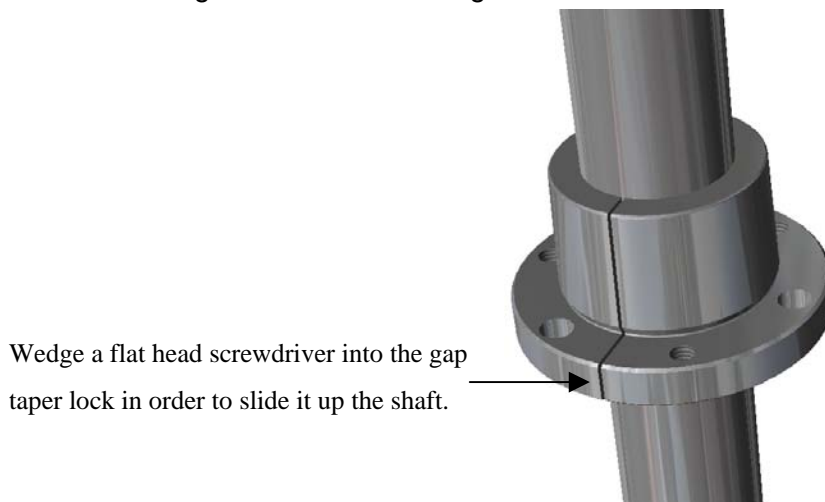

Figure 1-11. Taper Lock on Shaft

24. Install the set collar against the four-bolt flange and install the lower core with the four bolts provided.

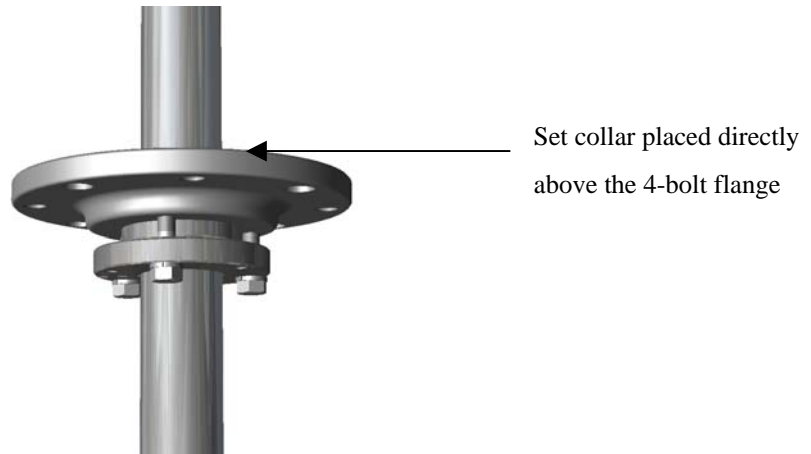

Figure 1-12. 4-Bolt Flange for Lower Core

25. Install the split hub for the upper core above the four-bolt flange, slide the upper core over the split hub and tighten with the three 1/4" bolts provided.

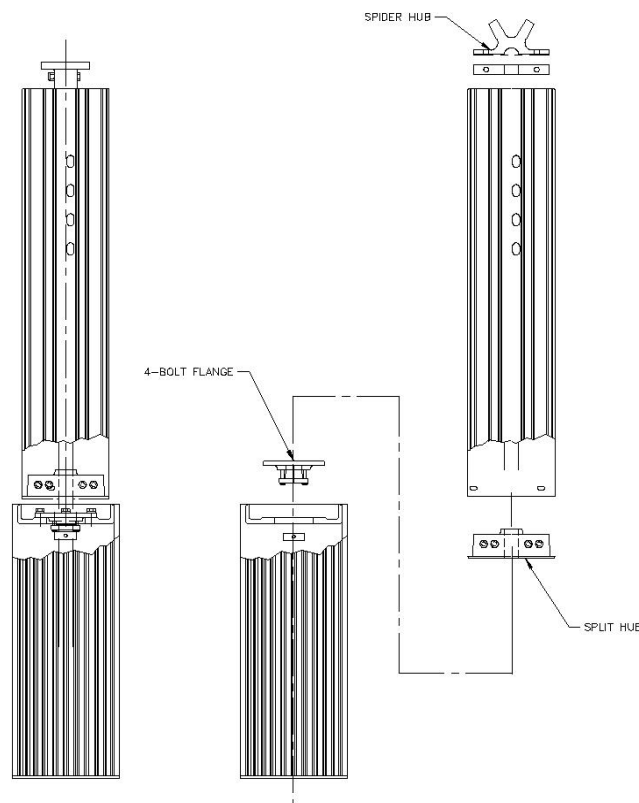

Figure 1-13. Core Assembly Orientation Over the Shaft

1.2.3 Positioning the Bumper Stops

26. It is imperative that the bumper stops be positioned correctly. Failure to do so may result in vehicle and equipment damage
27. Upon installation, the bumper stops must be tested prior to attaching the cylinders or the shocks
28. To test the bumpers, install them as shown in figure 1-14.
29. Slowly move the arms by hand, in and out. Check the rest position of each brush to assure proper arm motion.
30. The brushes should reach the centerline of the car wash tunnel when extended (in) and reach the position shown in figure 1-13 when retracted (out).
31. Reattach the cylinders and shocks as described in the following section of the manual. Re-check the arm motion by hand.
32. Neither the cylinders nor the shock should “bottom-out” in either the extended or retracted position. If this occurs reset the bumper stops to one of the available holes in the bumper stop brackets.
33. Once the bumper tops have been set to their final position, permanently secure them in place by tightening the bolts.

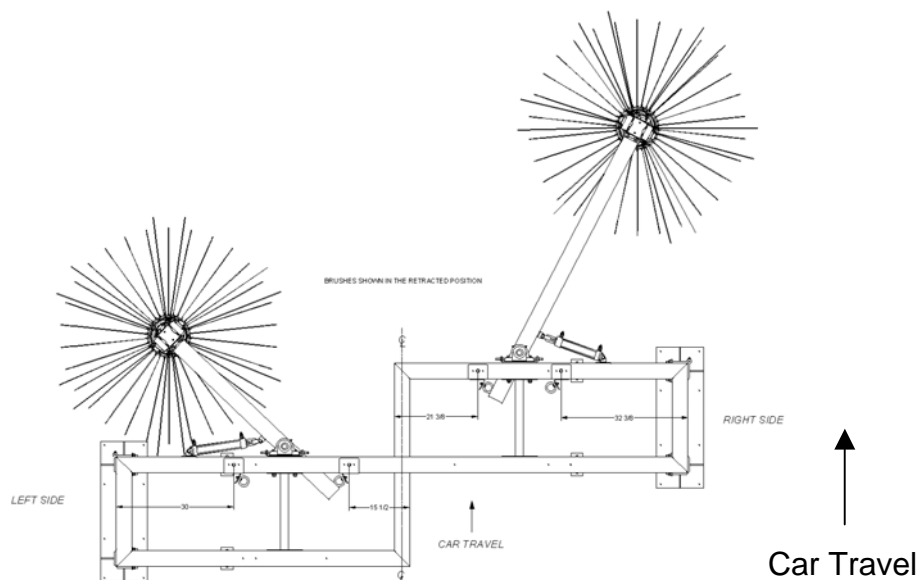

Figure 1-14. Focus Wrap in Retracted Position

34. The arm positioning shown in figure 1-14 is in the fully extended position. The bumper stops have been positioned to allow the brushes to reach centerline. This 'cross-over' is required for the washing of the front and rear of vehicles.
35. When the brushes engage the front of a vehicle, they will scrub the front grill and bumper, while moving away from the center of the vehicle. This is the specialized function of these brushes.
36. After rounding the corner of the front bumper, the brushes will then thoroughly wash the sides of the vehicle while gently washing the area across the mirror.
37. As the wraps come around the rear bumper, the brushes will begin to move across the rear of the car.
38. When this washing action is further combined with the full range of cross-over, the brushes will provide good cleaning of the front and rear of any vehicle.

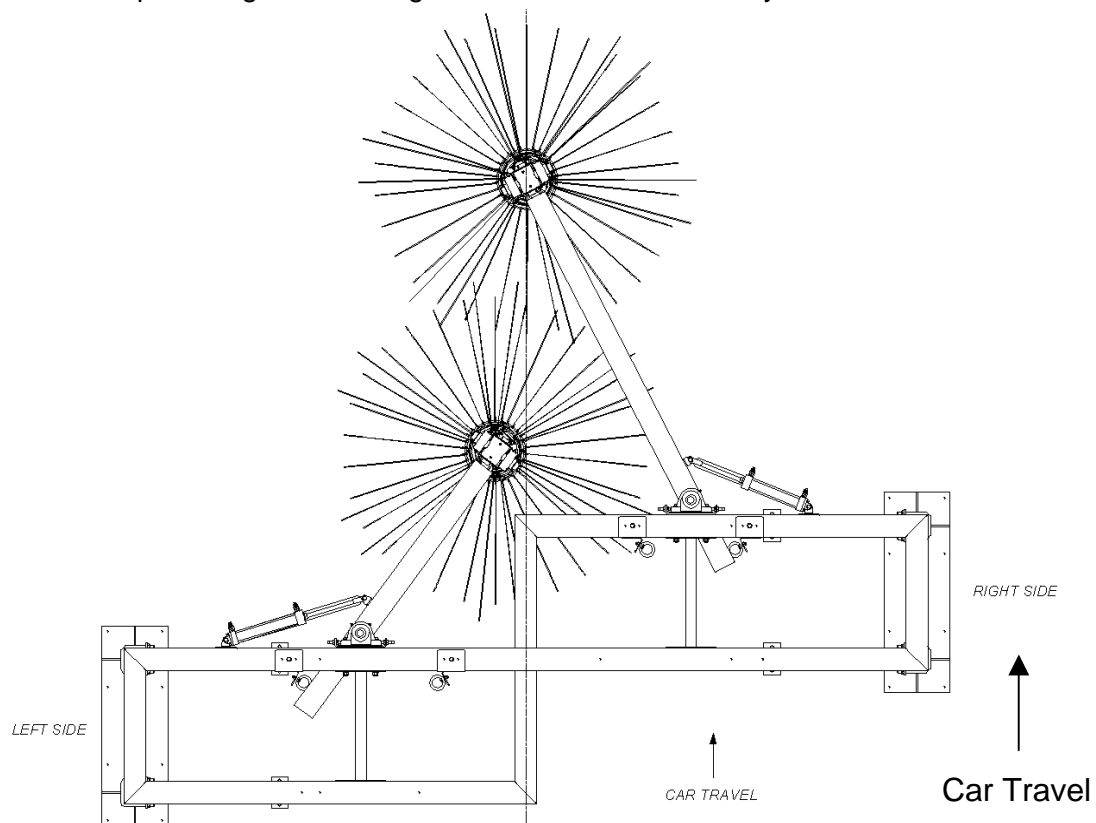

Figure 1-15. Focus Wrap in Extended Position

1.2.4 Installing the Shocks and Cylinders

39. When mounting the shock and cylinder assembly, make sure to place the cylinder assembly above the shock.
40. Connect the rod end bearing of the cylinder and the thinner end of the shock to the arm weldment. The thicker end of the shock and the base end of the cylinder to the header assembly.
41. Make sure that the hardware used to connect these items are secure but loose enough to move freely for the extension and retract to run smooth.

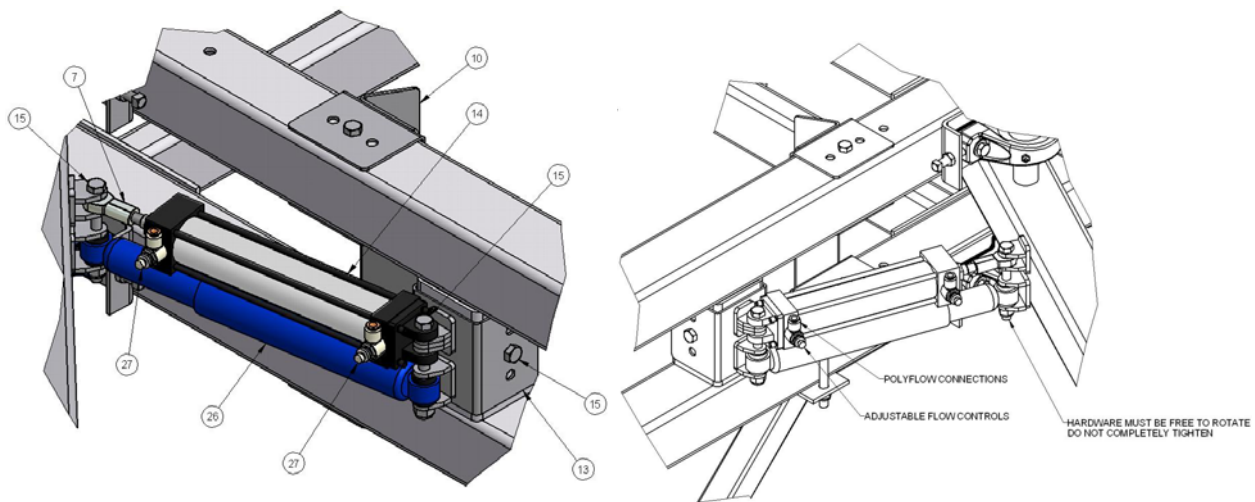

Figure 1-16. Shock and Cylinder Assembly

1.2.5 Leveling the Arms

42. There are two items on the Focus Wrap header that used to adjust the leveling of the arms; the leveling shims and the alignment adjusters as shown in figure 1-16.
43. Loosen the two bolts that hold the pillow lock bearing in place to add or remove the spacer shims. Only do this if the arm is not level. This can be checked when the leve is placed on the arm weldment (for horizontal alignment).
44. Tighten or loosen the alignment adjusters located on the bearing mount plate to straighten the arm weldment shaft (for vertical alignment).
45. To see if the arm is properly level and adjusted, the arm will stay at rest in any position. If the arm sways from one end to anther on its own, adjustments will have to be made until the arm will be able to stay in any position at rest (this test requires removing one end of the shock and air cylinder).

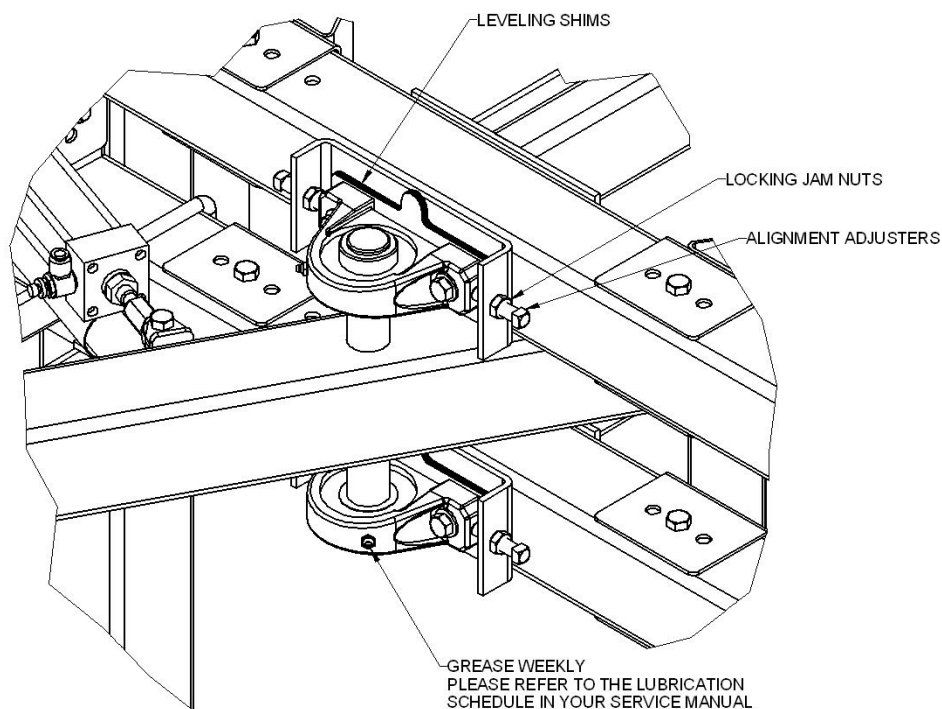

Figure 1-17. Where to Make Adjustments for Arm Leveling

1.3 Pneumatic Connections

This section covers the needed connections to make sure that all pneumatics are properly installed

46. (2) Pneumatic cylinder assemblies on the Hanna Focus Wrap require a total of (2) 3/8" poly air hose connections at an air volume of **.02 CFM per car on each cylinder**. There will be one dedicated connection for each of the four hoses leading to the pneumatic control box (two lines for extend motion and two lines for the retract motion).

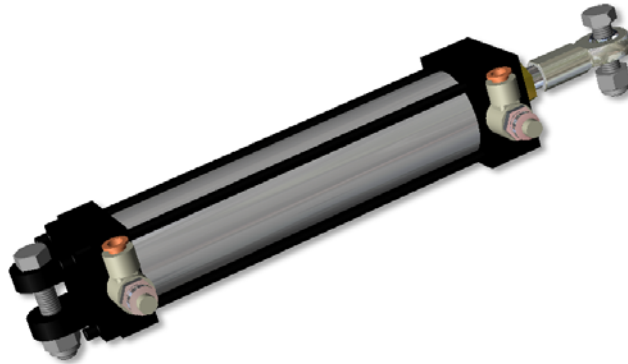

Figure 1-18. Pneumatic Cylinder Assembly

47. Figure 1-20 portrays the pneumatic control box for controlling the extend and retract command to the air cylinders.
48. During runtime, use the pneumatic flow adjuster on the cylinder to create a smoother extend and retracted movement across front and rear of vehicles. Turning the airflow adjustment knob (shown in figure 1-18) inward reduces arm travel speed and outward to increase arm travel speed. Use the stop adjustment ring to lock the adjuster screw.



Figure 1-19. Pneumatic Flow Adjustment

- 49. It is recommended that different color tubing be used for each of the extend and retract functions, this will make it easier to install the correct tube to the correct ports on the control box.
- 50. There will be (4) labels marked D/S Extend, D/S Retract, P/S Extend, and P/S retract on the bottom ports of the box.



Figure 1-20. *Pneumatic Control Box for the Hanna Focus Flex Wrap*

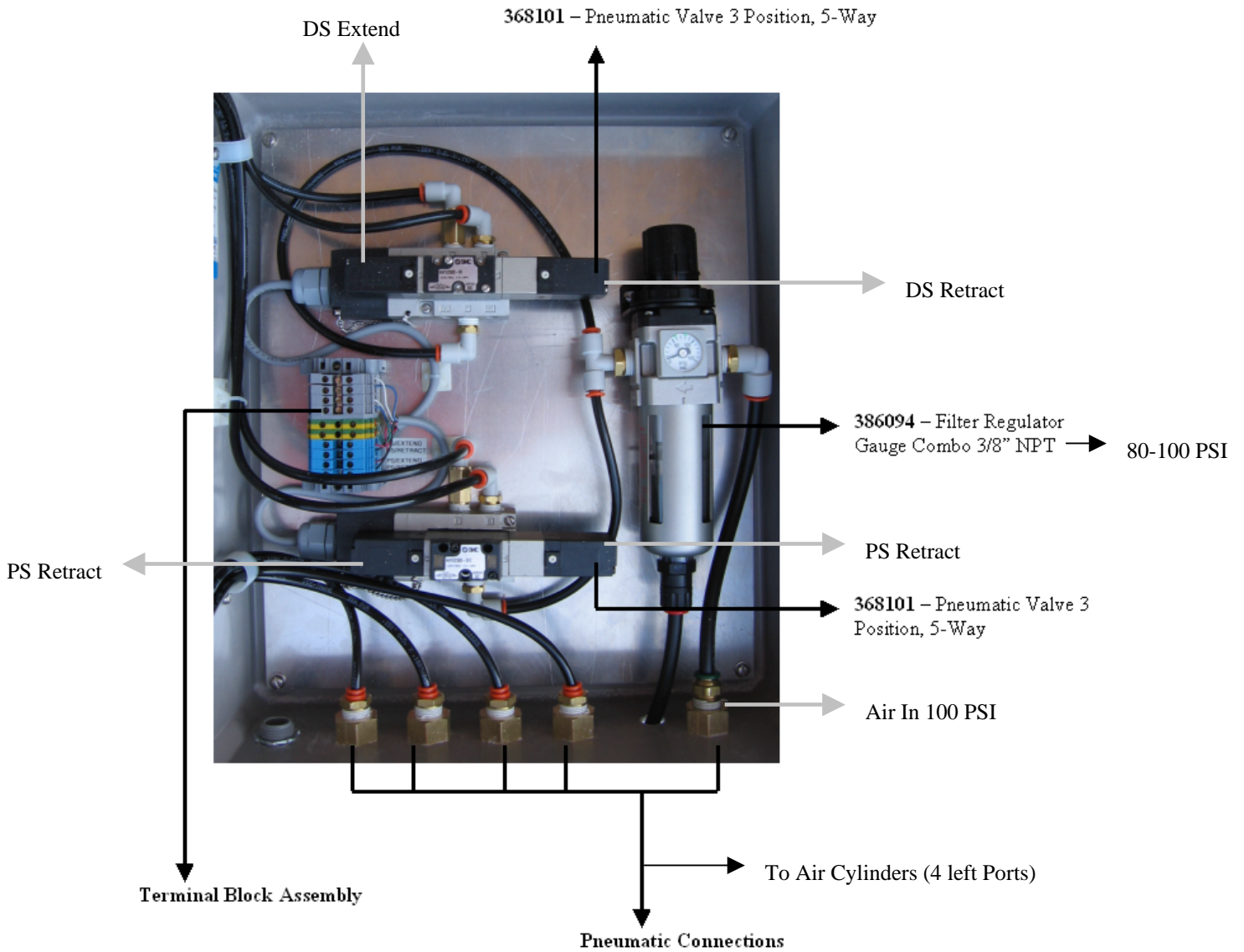

Figure 1-21. Right Hand Side of the Opened Control Box

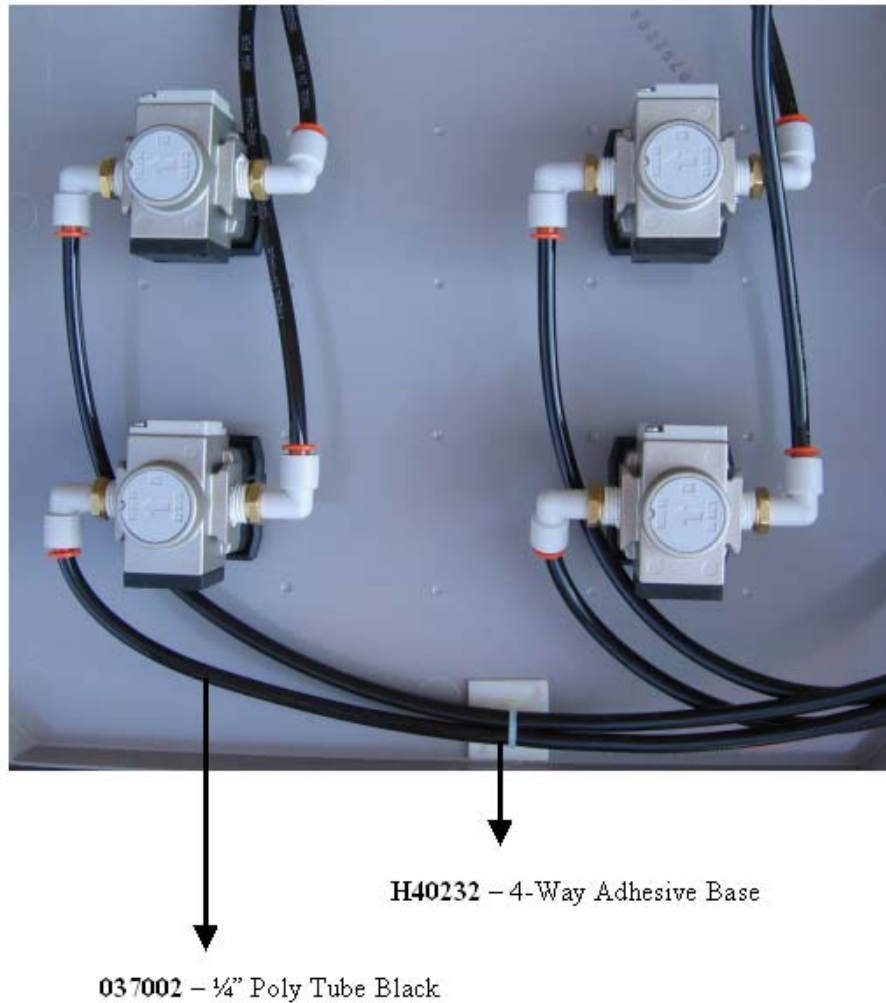

Figure 1-22. Left Hand Side of the Opened Control Box

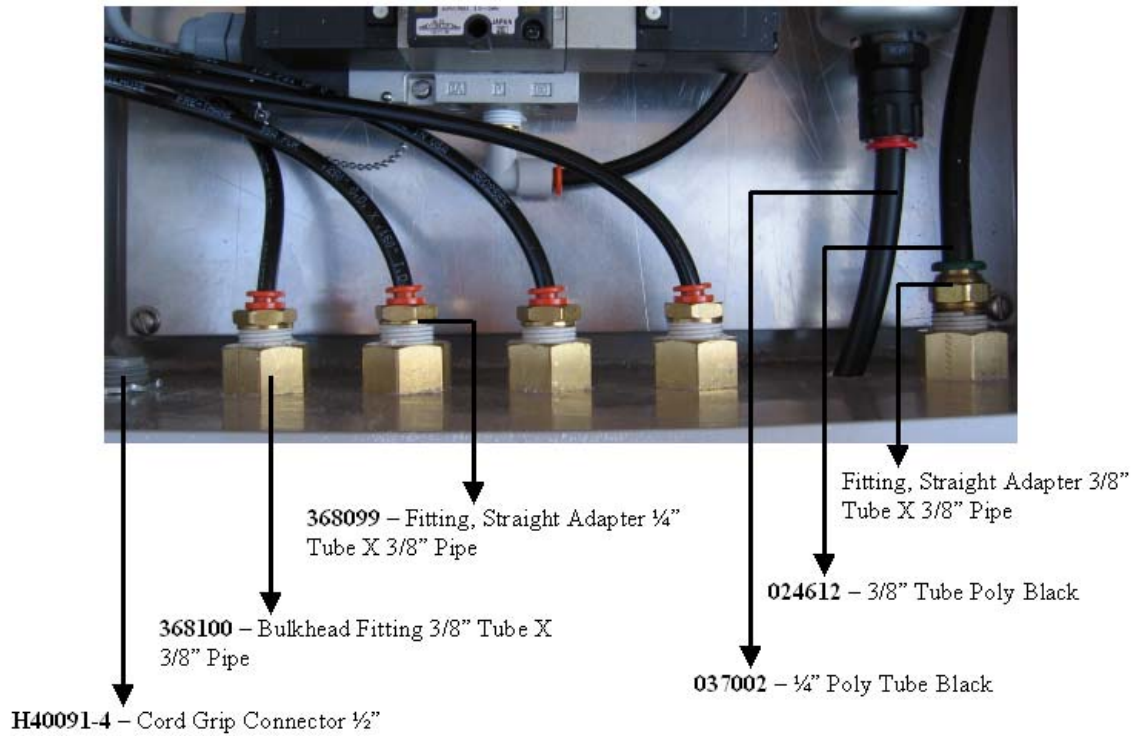

Figure 1-23. *Extend and Retract Ports on the Control Box*

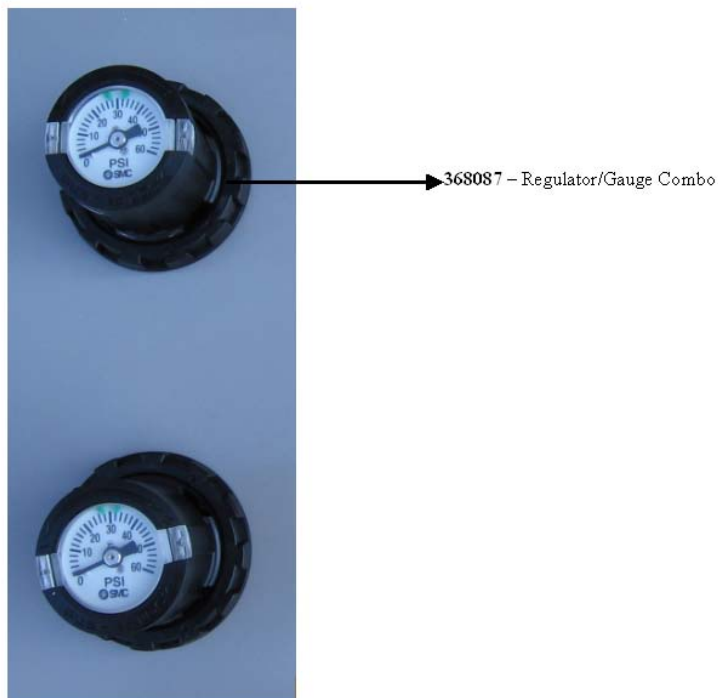

Figure 1-24. *Regulator Gauge*

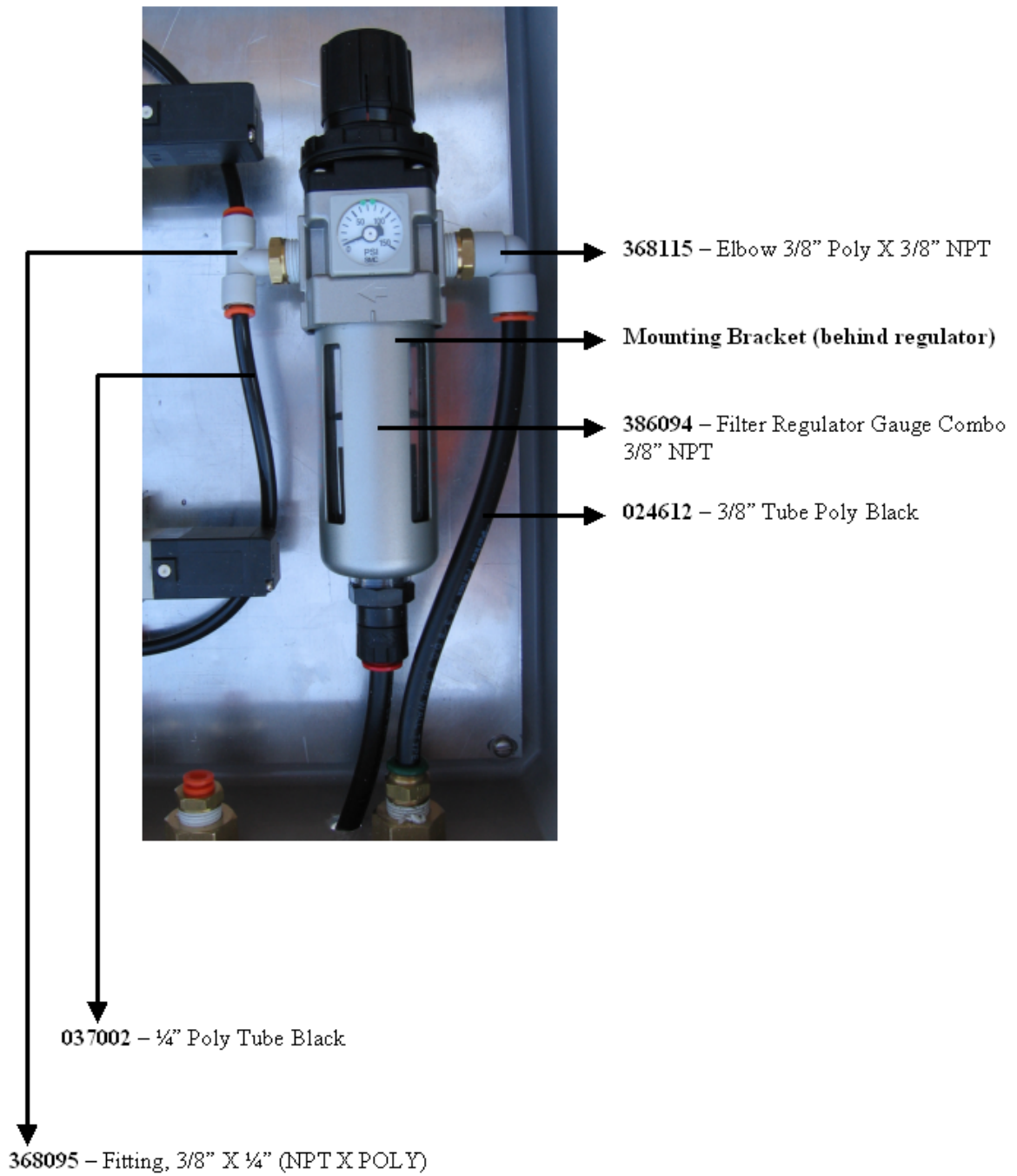

Figure 1-25. Filter Regulator

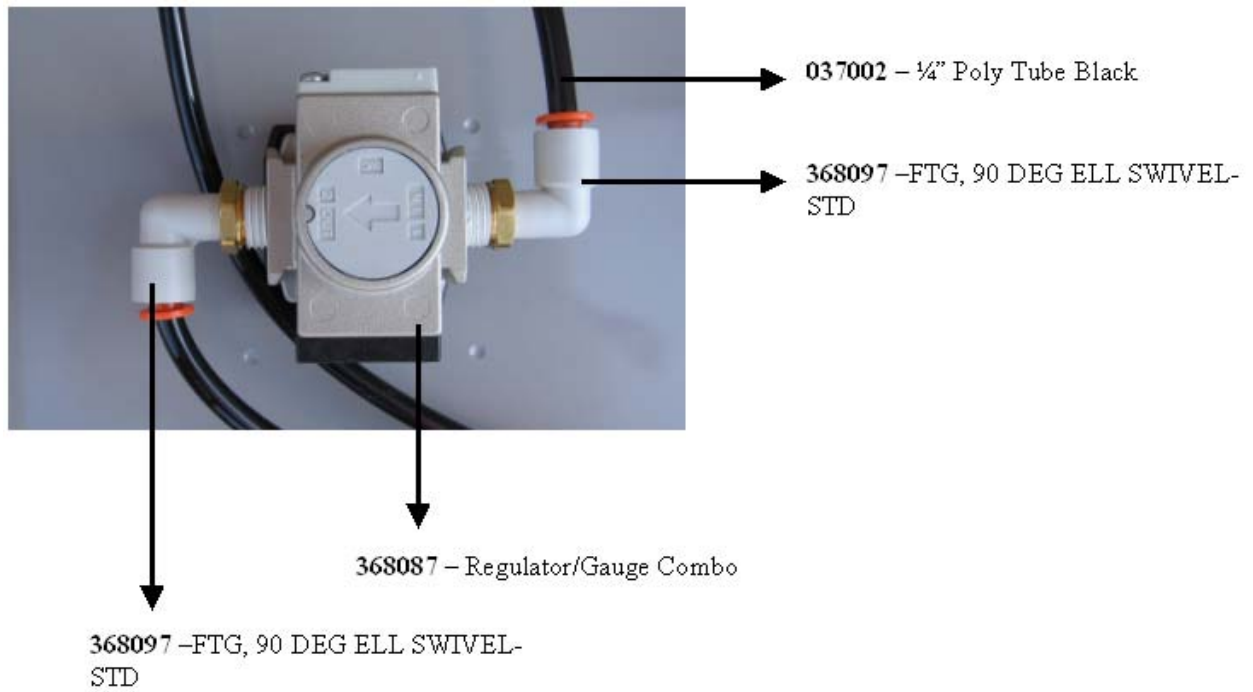

Figure 1-26. Close-up of the Regulator Gauge

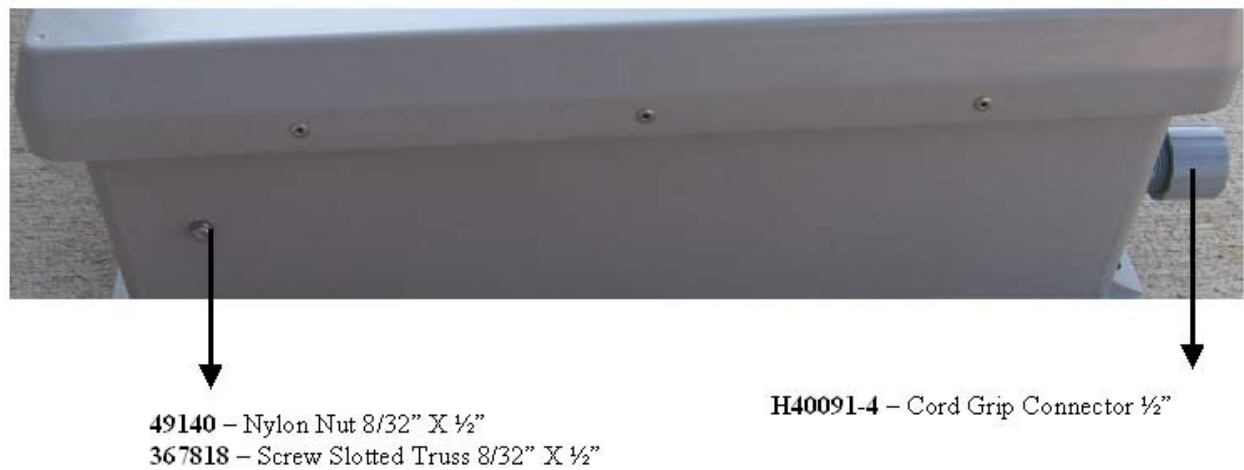

Figure 1-27. Outside Edge of the Control Box

1.4 Water Connections

This section covers the needed water connections to assure proper volume and pressure levels are met to operate this component.

51. There are two manifolds mounted on the Focus Wrap to wet the brushes down upon automobile entry. Each manifold requires a **flow of 9 GPM** at a **pressure of 40 PSI**.

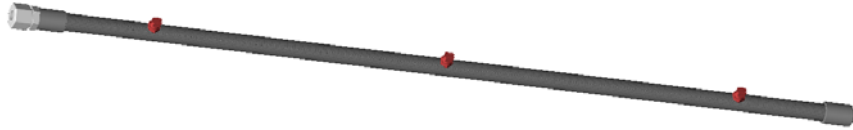

Figure 1-28. Water Manifold

52. Connect ½" poly flow to the nylon fitting located at the end of the manifold.
53. The Focus Flex Wrap can use reclaim or fresh water to feed to the manifold. Make sure that you are meeting the flow and pressure requirements to properly run the manifold. If pressure and flow are not met to engineering specifications, the cloth saturation level will not allow for quality car washing.

1.5 Hydraulic Connections

This section covers the hydraulic requirements and connections needed to operate the Hanna Focus Wrap.

54. A **3.0 - 3.5 GPM** flow rate at a pressure of **500 PSI** is required out of one priority valve from the hydraulic unit. **50-60 RPM** is the recommended rotation speed with cloth brushes.

55. The motors are connected in a series circuit. See figure 1-2p to see what these motor ports and flow direction look like on the Focus Wrap.

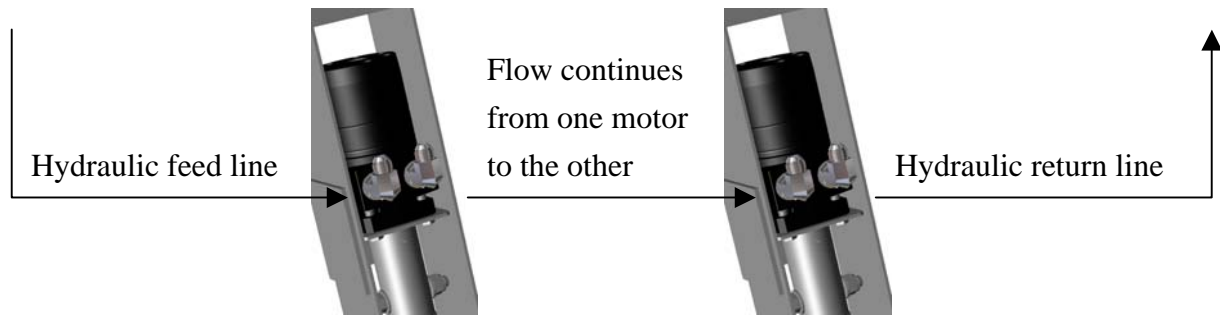

Figure 1-29. Motors and Flow Direction used for Brush Rotation on the Focus Wrap

56. Install all hydraulic lines and fittings. Be sure to properly install Triple-Loc fittings by tightening by hand first then using the wrench make one full turn then an additional $\frac{3}{4}$ turn.

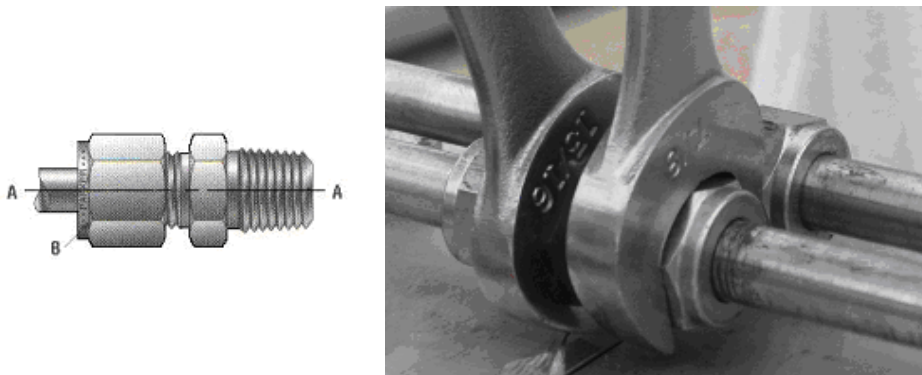

Figure 1-30. Tightening the Triple-Loc Fitting

57. Connect hydraulic lines (both pressure and return) from your mitter to your Hydraulic Power unit. Connect (electrically) the hydraulic solenoid (provided with the hydraulic unit) and the water solenoid to the car wash controller.

1.6 Pneumatic Control Box Electrical Connections

58. Attach control box to wall.

59. Bring-in the (5) functions required as shown below.

- Funct 1. Hydraulic and Water solenoid #1 and #2
- Funct 2. Driver Side Extend – (24VAC) solenoid #3
- Funct 3. Driver Side Retract – (24VAC) solenoid #4
- Funct 4. Passenger Side Extend (24VAC) solenoid #5
- Funct 5. Passenger Side Retract (24VAC) solenoid #6

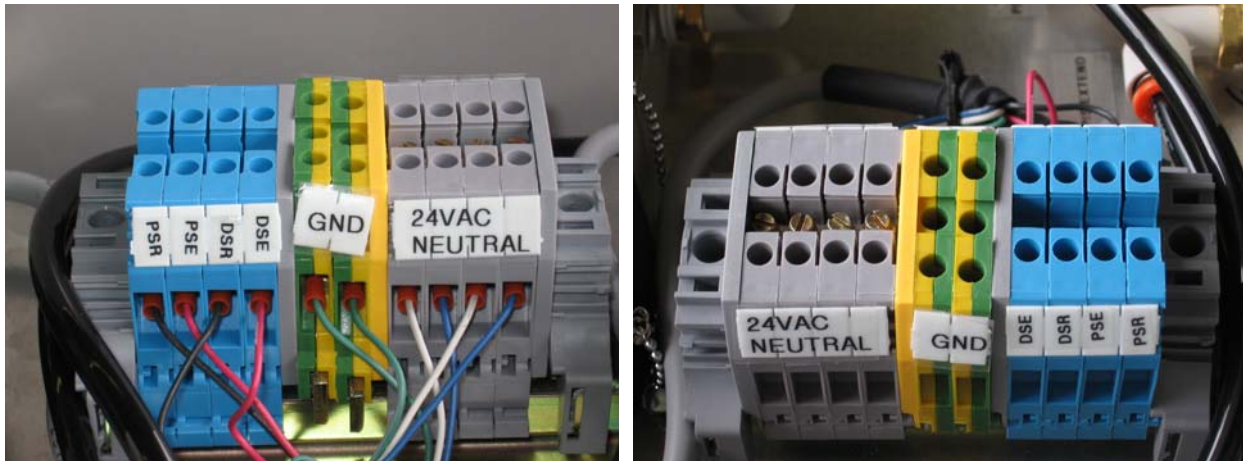

(Pre-Connected Wiring to Solenoids) *(Terminals that Must be Wired to the Controller)*
Figure 1-31. Terminal Block Assembly Inside the Control Box

60. Attach all ground wires to the ground provided. Attach additional ground if necessary.

61. Attach all neutral wires to the neutral portion of the terminal strip.

62. Attach **Driver Side Extend** function terminal labeled 'DSE'.

63. Attach **Driver Side Retract** function to terminal labeled 'DSR'.

64. Attach the **Passenger Side Extend** function labeled 'PSE'.

65. Attach the **Passenger Side Retract** terminal 'PSR'.
66. Attach the air supply to the isolation valve located on the outside of the pneumatic control box.
67. Do **NOT** attach the poly-flow air supply lines.
68. Open the isolation valve.
69. Set the internal regulator from 80 – 100 psi.
70. Set the door mounted regulators to the following pressures to start with, fine tune later:

Funct 1.	Driver Side Extend	10 psi
Funct 2.	Driver Side Retract	20 psi
Funct 3.	Passenger Side Extend	10 psi
Funct 4.	Passenger Side Retract	20 psi
71. You should notice air coming out of all four ports on the bottom of the control box. If air is not coming out of any of the ports, contact Hanna.
72. Once air is coming out of all four ports, activate the Driver Side Extend function at the controller. You should notice that the air supply from the Driver Side Retract port will stop.
73. Repeat this process for the Passenger Side functions.
74. Now that the computer functions match the plumbing and labeling of the control box, connect the poly-flow tubing for the cylinders to extend on the base end of the cylinders and the retract on the rod end.

1.7 Other Electrical Connections

75. Make sure the solenoids to the water, hydraulic, and pneumatic connections are in place and connected to the correct function on the tunnel controller.

1.8 Startup

The following section describes the occurring sequence of events that will occur after a proper installation.

76. First thing to check for upon startup is brush rotation. Correct brush rotation is critical to the performance of the Flex Wrap. Improper brush rotation will result in vehicle and equipment damage.

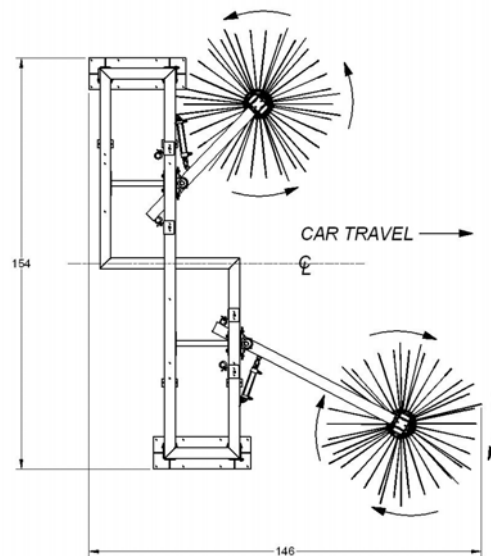

Figure 1-32. Brush Rotation of the Focus Flex Wrap

77. Hanna recommends that the brushes rotate while the hydraulic unit is on. This is to prevent any chances of an automobile drive-through from occurring, which may damage a vehicle.
78. As the vehicle approaches, two separate 24 VAC signals are sent to the 'extend' terminals of the pneumatic control box. This will bring both arms toward the centerline position.
79. The signal is held on for the entire vehicle length. From this point on, each function must be separated from driver side to passenger side. This will help eliminate vehicle and shaft damage from vehicle drive through.

80. As the vehicle makes contact with the first brush (driver's side), the brush will begin to crawl across the front of the vehicle, away from the centerline. If your brush is rotating the wrong direction, switch the hydraulic lines leading to the hydraulic motor. This will reverse the brush direction
81. Once the brush has traveled around the front corner of the vehicle, an additional 24VAC signal is sent to the driver's side retract function. At this time both extend and retract signals are on. This will cause the valve to go to a neutral position, allowing air to both push and pull on the brush at the same time. The result, depending on your regulator settings, is a soft gentle wash force on the side of the vehicle especially around the external mirrors and antennas.
82. As the brush approaches the rear quarter panel of the vehicle, the retract signal is cancelled, this returns full pressure to the brush which aids the brush in washing the back of the vehicle.
83. The point at which the retract function is energized or de-energized is programmable and may be customized but the wash owner. However, it is required around the external mirror on all vehicles.
84. Once the brush wraps around the rear of the vehicle, it is pre-positioned for the next vehicle.
85. This same process is duplicated for both sides of the Focus Wrap with the only exception being the activation point due to the offset in the Focus Wrap Frame.

1.9 Installation Check List

Make sure that all installation procedures have been checked and confirmed to be correct.

Check Off	Install Procedure
	Structure is mounted over the centerline
	Brush core assemblies are secure and installed to the box and shaft subassembly
	All bearing grease fittings have been located and identified for future access
	The bumper stops have been positioned and secured
	Shocks and cylinder assemblies have been properly attached and installed
	Arms have been leveled
	Pneumatic control box is installed
	Pneumatic connections lead to the correct ports
	Water connections are installed and are ran with the correct volume and pressure
	Hydraulic connections are installed and are ran with the correct volume and pressure
	Electrical connections are installed and are ran with correct timing and power requirements
	Brush rotation has been checked and is running in the correct direction
	Start up procedures have been read and understood



1.10 Hanna Hydraulic Tubing Color Code

Hanna uses colored tape on all hydraulic tubing at the factory. Figure 3-14 shows the color code on all Hanna hydraulic operated equipment.



HANNA











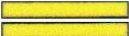



HYDRAULIC TUBING COLOR CODE		
EQUIPMENT	COLOR CODE	
Pressure Line	1 Stripe	
Return Line	2 Stripes	
Wraparound 98-C or Flex	Black	
Tire Washer	Brown	
HCRP	White	
Auto Prep	Purple	
SHWW or ASWW	Green	
Mitter Any Model	Blue	
Top Washer or Any Mitter	Yellow	
SPARE COLORS		
Also Code the Following:		
Superwave, High PSI Arch	Red	
and Any 2nd Brush in Syst.	Orange	
Multi Equipment Combo's		
1st Mitter in System	Blue	
2nd Mitter	Yellow	
3rd Mitter	Red	
1st ASWW in System	Green	
2nd ASWW	Orange	
3rd ASWW	Red	

Figure 3-33. *Hydraulic Color Coding*

2.0 Safety

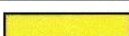
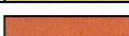
Keep the following safety rules in mind when installing and using Hanna Car Wash Systems

NOTE: *Always follow local and national trade codes when installing any equipment.*

- Always disconnect power from any electrical device or component prior to servicing.
- Unplug the unit or use proper lock-out procedures so that no one can inadvertently turn the power on while you are working on that equipment.
- Use caution when maintaining any piece of equipment.
- Wear protective clothing and eyewear when using power tools.
- Direct discharge of high-pressure water and chemicals away from you and other persons, or direct it into approved containers.
- Keep equipment clean for proper operation.
- Keep hands or any body parts away from equipment while in operation.
- If you need to disassemble a part for service or repair, re-assemble equipment according to instructions.
- Be sure all components are firmly screwed or latched into position.
- Observe safety and handling instructions of the chemical manufacturers.
- Wear protective clothing and eyewear when dispensing or working with chemicals or other potentially hazardous materials.

2.1 Cautions, Warnings, and Notes

Throughout this manual there are various messages concerning safety – please heed these warnings!

2.1.1 Cautions

Cautions warn against a potential hazard that, if not avoided, may result in minor or moderate injury. Caution signs also alert against unsafe practices that may cause property damage.



CAUTION:

2.1.2 Warnings

Warning messages warn against a potential hazard that, if not avoided, may result in serious injury or death.



WARNING:

2.1.3 Notes

Note means reader take note. Notes contain helpful suggestions.

NOTE: *This parameter should NOT be changed when attempting to make system adjustments.*

This page is intentionally left blank.



Jim Coleman Company/Hanna Car Wash Systems

Main Office

5842 West 34th Street
Houston, TX 77092

800-999-9878 • 713-683-9878 • Fax: 713-683-9624
www.jcolemanco.com

Hanna Division Office

7905 Blankenship Dr.
Houston, TX 77055

866-683-6615 • 713-683-6615 • Fax: 713-590-6630
www.hannacarwash.com