

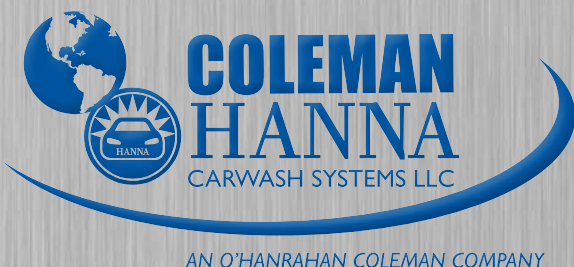

# Finishing Touch Mitter

## *Service Manual*



5842 W 34th St, Houston, TX 77092  
1.800.999.9878 • 1.713.683.9878  
[www.colemanhanna.com](http://www.colemanhanna.com)



Find us on Facebook:  
[/ColemanHannaCarwash](https://www.facebook.com/ColemanHannaCarwash)

# Table of Contents

- 1.0 INTRODUCTION..... 1-1**
  - 1.1 Design Features .....1-2
  - 1.2 Basic Operation.....1-5
  
- 2.0 SAFETY ..... 2-1**
  - 2.1 Cautions, Warnings, and Notes .....2-2
  
- 3.0 INSTALLATION..... 3-1**
  - 3.1 Performance Requirements .....3-1
  - 3.2 General Requirements .....3-2
  - 3.3 Setup.....3-2
  - 3.4 Structure Installation .....3-3
  - 3.5 Water Connections.....3-6
  - 3.6 Hydraulic Connections .....3-7
  - 3.7 Installing the Curtains.....3-10
  - 3.8 Hanna Hydraulic Tubing Color Code .....3-11
  
- 4.0 PARTS AND MAINTENANCE..... 4-1**
  - 4.1 General Maintenance.....4-1
  - 4.2 Lubrication.....4-2
  - 4.3 Bearing Replacement.....4-3
  - 4.4 Spare Parts List.....4-9
  - 4.5 Catalog of Replacement Parts .....4-10
  
- 5.0 TROUBLESHOOTING..... 5-1**
  - 5.1 Mitter Problems .....5-1
  - 5.2 Hydraulic Fitting Problems .....5-2

## **Table of Figures**

Figure 1-1	Hanna's Finishing Touch Mitter .....	1-1
Figure 1-2	HFTM Header Frame .....	1-2
Figure 1-3	HFTM Support Leg.....	1-2
Figure 1-4	Double Gusset Support Brace .....	1-3
Figure 1-5	Basket Weldment .....	1-3
Figure 1-6	Flow Control Assembly.....	1-4
Figure 1-7	Overhung Load Adapter .....	1-4
Figure 1-8	Spray Manifold.....	1-4
Figure 1-9	HFTM Cloth Curtains. ....	1-5
Figure 3-1	Isometric View of the HFTM.....	3-1
Figure 3-2	Header Layout According to Car Travel .....	3-2
Figure 3-3	Mounted Post-to-Header Gusset.....	3-4
Figure 3-4	Mounted Double Gusset.....	3-4
Figure 3-5	Plumb Bob .....	3-4
Figure 3-6	Centerline Structure Orientation .....	3-5
Figure 3-7	Anchor Bolt.....	3-5
Figure 3-8	Spray Manifold.....	3-6
Figure 3-9	Valve Assembly .....	3-6
Figure 3-10	Hydraulic Motor .....	3-7
Figure 3-11	Tightening the Tiple-Loc.....	3-7
Figure 3-12	Priority/Flow Control Assembly.....	3-8
Figure 3-13	Open/Closed PCM Valve.....	3-8
Figure 3-14	Priority Valve Adjustment .....	3-9
Figure 3-15	HFTM Cloth Length.....	3-10
Figure 3-15	Hydraulic Color Coding.....	3-11
Table 4-1	Grease Application Conditions .....	4-2
Figure 4-1	Top View of Basket Bearings .....	4-3
Figure 4-2	Wrench and Adapter Locking Nut.....	4-3
Figure 4-3	Bearing Housing with Nuts, Washers, Bolts .....	4-3
Figure 4-4	Different Stages of the Bearing Assembly.....	4-4
Figure 4-5	Adapter Sleeve .....	4-4
Figure 4-5	Adapter Sleeve Secured to Nut .....	4-5
Table 4-2	Recommended Spare Parts .....	4-5

## 1.0 Introduction

The Hanna Finishing Touch Mitter (FTM) represents the continuing innovation of Hanna developed and Hanna tested modular car wash systems. This side-supported stainless-steel mitter offers superior cleaning while gently washing all types and shapes of vehicles.

Two stainless steel baskets, each with 40 curtains that are cut to consist of 80 curtain strips, concentrate on softly cleaning the top horizontal surfaces of the vehicle. The two stainless steel curtain racks move diagonally to create a figure-8 curtain motion, which provides a unique movement to carefully contour the shape of the vehicle.

The Finishing Touch Mitter is offered in both a stainless steel and aluminum frame construction with either a hydraulic or electric power driven motor that can accommodate varying budgets and car wash environments based on the buyer's needs.



**Figure 1-1. *Hanna's Finishing Touch Mitter (Free Standing)***

## 1.1 Design Features

### 1.1.1 Frame

The frame of Hanna's FTM is available in two height options — 90 in. and 96 in. Both of these frame heights offer strength, rigidity, and long-life. The framework of the FTM has three main elements — legs, a header weldment, and support bracing.

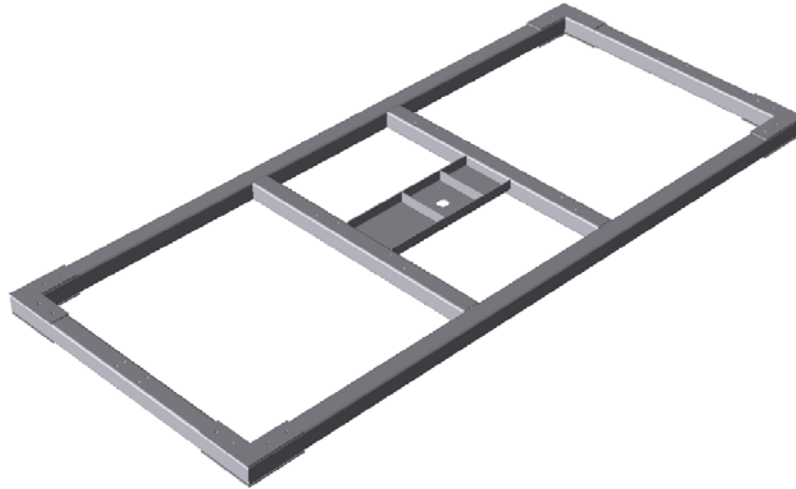

Figure 1-2. *Hanna FTM Header Frame*

### 1.1.2 Legs

The legs (or posts) of the FTM are constructed entirely of high quality rigid aluminum or stainless steel and have been designed to maximize strength, rigidity, and long-life. All legs come with pre-drilled holes for easy alignment and installation.

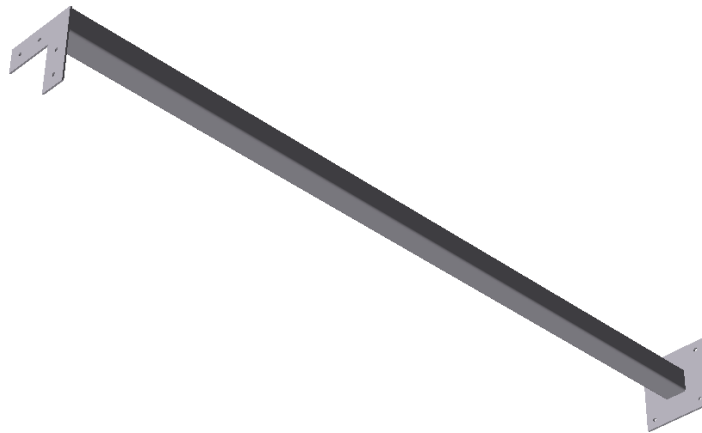

Figure 1-3. *Hanna FTM Support Leg*

### 1.1.3 Double Gusset

As an upgrade to the cable brackets from the existing XT structure, Hanna has developed a triangular support brace called the Double Gusset. This new support bracing reduces overall vibration caused from basket and shaft movement, adds greater rigidity, is easier to install, and of course is cost effective. Two double gussets are required per component that used the old cable bracing and are on the mitter components.

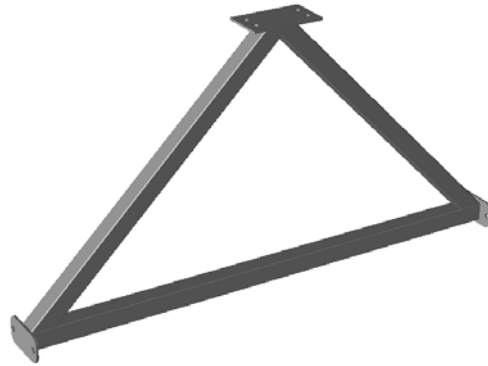

Figure 1-4. *Double Gusset Support Brace*

### 1.1.4 Exit and Entrance Basket Weldment

The Mitter exit and entrance basket weldment exhibit horizontal movement (back and forth) in the direction of vehicle travel and vertical lift. The vertical lift contributes greatly to provide superior cleaning on the top and sides of vehicles. Running the hydraulic motor at a proper speed of 30-35 revolutions per minute, the rigid frame design will last beyond the competition.

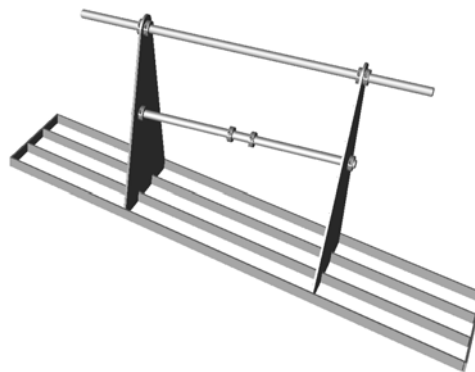

Figure 1-5. *Basket Weldment*

### 1.1.5 Gauge and Flow Control Valve

Hanna research and development has utilized the flow control valve to smooth out the outgoing hydraulic fluids of the motor. This fluid flow control provides the wash owner great control over his/her ability to smooth motor and crank arm rotation, greatly reduce vibrations.

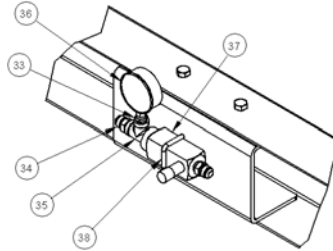

Figure 1-6. *Flow Control Assembly*

### 1.1.6 OHLA for Hydraulic Motor

The OHLA (Overhung Load Adapter) is a gear box designed to help the hydraulic motor generate smoother motion and control to the crank arm.

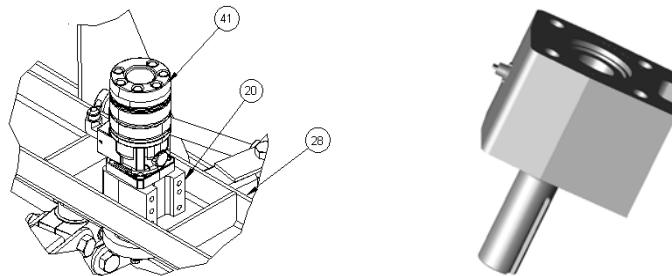

Figure 1-7. *Overhung Load Adapter with Hydraulic Motor*

### 1.1.7 Spray Manifold

Two spray manifolds connected to a solenoid apply the proper water needed to wet down the curtains. Mounted in the header frame, a flow of 12 gallons per minute at 40 psi are required to properly wet the curtain cloth material.



Figure 1-8. *Spray Manifold*



### 1.1.8 Cloth Material

The cloth panels that attach to the mitter rack are manufactured of a mixture of polyethylene and nylon copolymer fibers needled together. The cloth has a fuzzy aggressive texture. There are two stainless steel curtain racks with 40 curtains per rack.

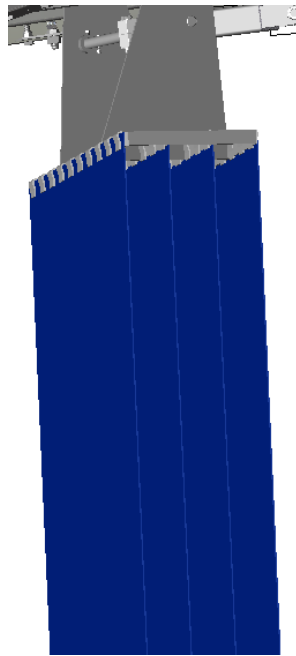

Figure 1-9. *HFTM Cloth Curtains*

## 1.2 Basic Operation

The Hanna FTM is designed to activate as a vehicle approaches and shut off as the vehicle moves past the mitter curtains. This is accomplished with a hydraulic solenoid valve on the hydraulic power unit. Water to wet down the curtains is activated by a solenoid valve and can be fresh water or reclaim.

The Hanna FTM features two stainless steel angled curtain racks with 40 curtains each moving diagonally (back and forth) opposite to give superior cleaning of the horizontal surfaces of a vehicle. The forward and backward movement creates a figure-8 motion in the curtains as it gently cleans the vehicle and conforming to the vehicle's shape without incident to the roof racks, lights, and antennas.



This page is intentionally left blank.

## 2.0 Safety

Keep the following safety rules in mind when installing and using Hanna Car Wash Systems Equipment:

**NOTE:** *Always follow local and national trade codes when installing any equipment.*

- Always disconnect power from any electrical device or component prior to servicing.
- Unplug the unit or use proper lock-out procedures so that no one can inadvertently turn the power on while you are working on that equipment.
- Always power down the control box before unplugging or plugging in quick disconnects.
- Use caution when maintaining any piece of equipment.
- Wear protective clothing and eyewear when using power tools.
- Direct discharge of high-pressure water and chemicals away from you and other persons, or direct it into approved containers.
- Keep equipment clean for proper operation.
- Keep hands or any body parts away from equipment while in operation.
- If you need to disassemble a part for service or repair, re-assemble equipment according to instructions.
- Be sure all components are firmly screwed or latched into position.
- Observe safety and handling instructions of the chemical manufacturers.
- Wear protective clothing and eyewear when dispensing or working with chemicals or other potentially hazardous materials.

## 2.1 Cautions, Warnings, and Notes

Throughout this manual, there are various messages concerning safety – please heed these warnings! The following sections give some examples of these safety messages.

### 2.1.1 Cautions

Cautions warn against a potential hazard that, if not avoided, may result in minor or moderate injury. Caution signs also alert against unsafe practices that may cause property damage.



**CAUTION: *DO NOT TOUCH THE BLUE BUTTON! IT IS THE SYSTEM BUTTON AND USED FOR CONFIGURATION.***

### 2.1.2 Warnings

Warning messages warn against a potential hazard that, if not avoided, may result in serious injury or death.



**WARNING: *DO NOT REMOVE PLUGS UNDER ELECTRICAL POWER. MAIN ELECTRICAL POWER MUST BE SHUT OFF BEFORE DISCONNECTING OR CONNECTING ANY PLUG OR CABLE ON THE SPRAY HEAD.***

### 2.1.3 Notes

Note means reader take note. Notes contain helpful suggestions.

**NOTE: *This parameter should NOT be changed when attempting to make system adjustments.***

## 3.0 Installation

The following information is a recommended means for installation of the Hanna Finishing Touch Mitter. Check for the local utilities, making sure of proper access location and supply sizing. If anything must be changed, do so prior to the day of installation. Deficiencies discovered at the time of installation will greatly increase time spent before startup.

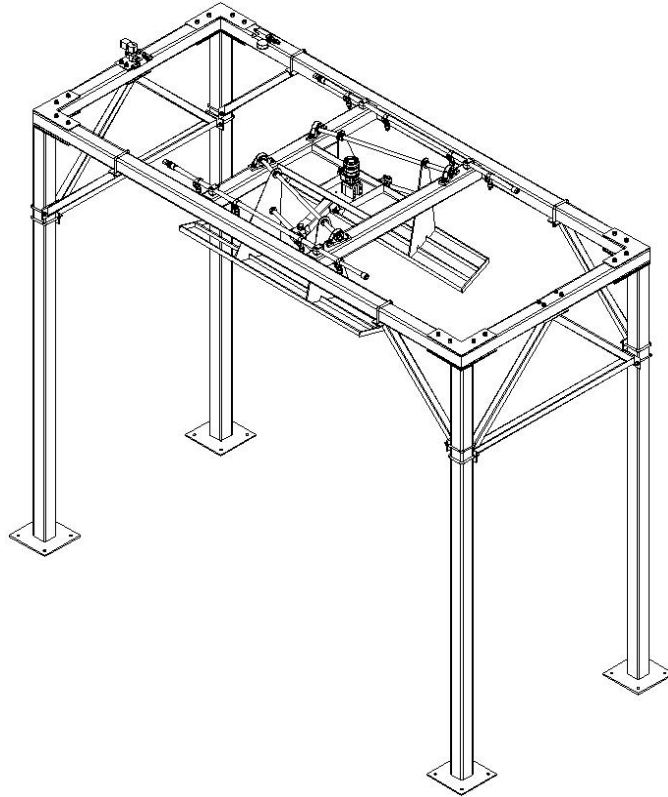

**Figure 3-1** *Isometric Layout of the Hanna Finishing Touch Mitter*

### 3.1 Performance Requirements

- Water: 12 GPM @ 40 PSI
- Hydraulic: 3 GMP with 400-500 PSI inlet pressure with 200-300 PSI outlet pressure
- Motor Rotation Speed: 30-35 RPM
- Pressure Drop: 200 PSI approximately
- Dimensions: Please refer to the layout drawing provided with this manual

## 3.2 General Requirements

Before getting started, you must find the proper location for your new Hanna FTM. We recommend a minimum length of 10 ft. (3.05 m) clear area for proper operation of a system configuration. The clear area is defined as any space that allows the mitter to operate freely, but will not interfere with other devices.

## 3.3 Setup

1. Read this manual prior to opening crates or installing equipment.
2. Carefully open crates and identify the individual parts for assembly using the enclosed checklist. If there are any missing parts, notify your Hanna distributor immediately.



**WARNING: WHEN USING A FORKLIFT TO INSTALL EQUIPMENT MAKE SURE TO FOLLOW OSHA AND GENERAL SAFETY RULES AND REGULATIONS TO ENSURE PERSONAL SAFETY.**

3. Place the framework in the wash bay as shown on the layout drawing (available if purchased with system). Make sure the framework is facing the correct direction for vehicle travel. When all pieces for your configuration have been set in place, take the time to recheck the packing lists.
4. Make sure all of the necessary tools are on-hand before work is begun.
  - ✓ Set of ratchets/wrenches to secure bolts, nuts, connections, anchors, etc.
  - ✓ A mason drill to set the pilot holes for the anchor bolts.
  - ✓ Large hammer to insert the anchor bolts to the ground.
  - ✓ A power grinder to remove excess material from the anchor bolts.
  - ✓ Tube cutters for poly connections.
  - ✓ Blade/box cutter.
  - ✓ Leveling tool to assure that the structure is accurately square.
  - ✓ Tape measure to acquire proper distances and identifying marks.
  - ✓ Plumb bob to align the component to the centerline of the tunnel.
  - ✓ Teflon tape for fittings.
  - ✓ Anti-seize for stainless steel hardware attachment.
  - ✓ Forklifts for heavy material

### 3.6 Structure Installation

5. Once the FTM parts have been placed in it's designated section of the tunnel, make sure that the header assembly is oriented correctly before it is mounted on the legs. Correct header orientation can be identified by the basket placement shown in figure 3-2. **Note: knowing the outer angle orientation of the baskets according the left and right hand side of the mitter are the best way to identify correct header placement.**

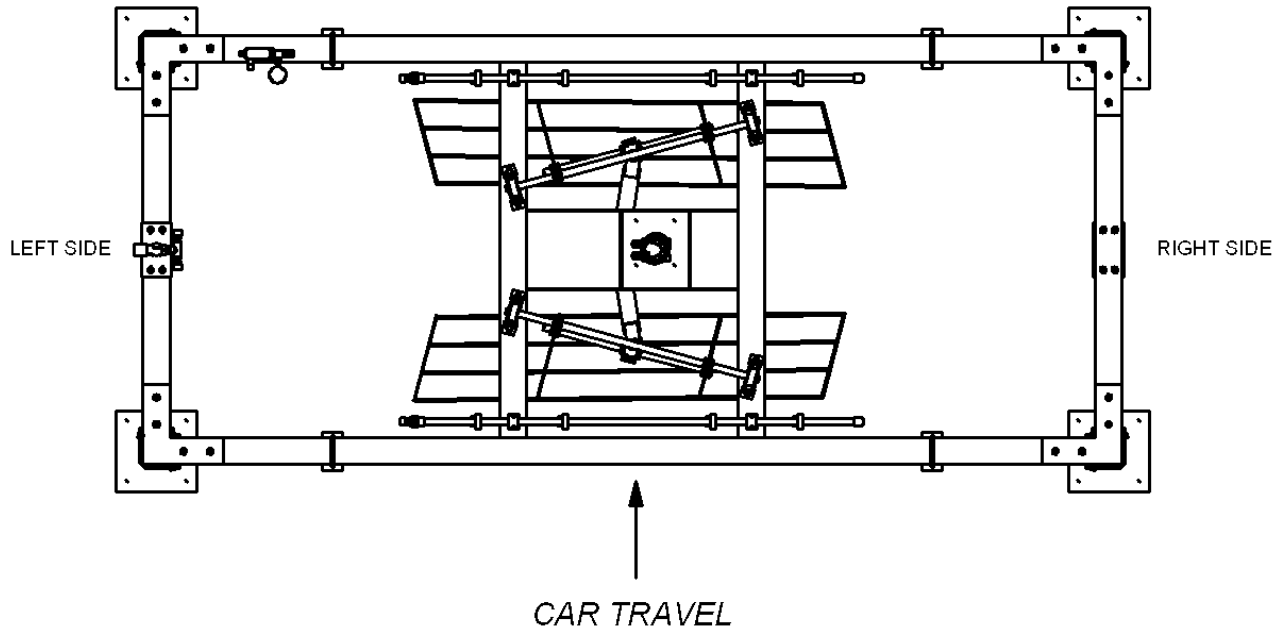

**Figure 3-2 Header Assembly Position According to Car Travel**

6. Using two forklifts, raise the header assembly to the (4) posts.
7. Once aligned, use the  $\frac{1}{2}$ " X  $5 \frac{1}{2}$ " bolts,  $\frac{1}{2}$ " flat washers, and  $\frac{1}{2}$ " esna nuts to secure the header assembly to the legs. **Note: When bolting the header to the legs make sure the head of the bolt is always on top of the structure and the washer and nut connect at the bottom. This will assure that the bolts will not fall if any nut should ever become disconnected.**

- Place the post-to-header gussets on the structure. All post-to-header gussets are mounted parallel with the header assembly facing the inside legs of the structure. Once aligned, use the provided 5 ½" U-bolts, ½" flat washers, and ½" esna nuts to secure all (4) of the gussets. (2) U-bolts will be required for every gusset.



**Figure 3-3. Mounted Post-to-Header Gusset**

- Place the Double Gussets on the structure. The two Double Gussets are mounted and each end of the header assembly facing to the left and right of the structure. Once aligned, use the provided 5 ½" straight and U-bolts, ½" flat washers, and ½" esna nuts to secure all (2) of the gussets. (2) U-bolts will be required for every Double Gusset.



**Figure 3-4. Mounted Double Gusset**

- Situate the structure so that it's perfectly over centerline of the carwash. Please refer to your M1 drawing to locate and reference where the centerline is to your system. Use the plumb bob and hang it from the center point of the FTM Header. If centered correctly, the tip of the plum bob will point to the centerline of the tunnel.



**Figure 3-5. Plumb Bob**



11. Using your level, make sure that the header assembly is perfectly straight. If the bubble in the level is not directly between the center marks, there may be problems with cleaning performances. To compensate for any unevenness in the header, the installer may have to place spacer plates under the base plate of the offset leg(s).
12. Double check for accuracy before anchoring the base plates. If centered correctly, there will be **75 1/2 inches** from the outer edge of each base plate to the centerline. Make sure that there is at least **2.5 feet of clearance from the exit side** and **2.5 feet of clearance from the entrance side**. This is so that the components in front of and behind the Hanna Finishing Touch Mitter may not be interfered with.

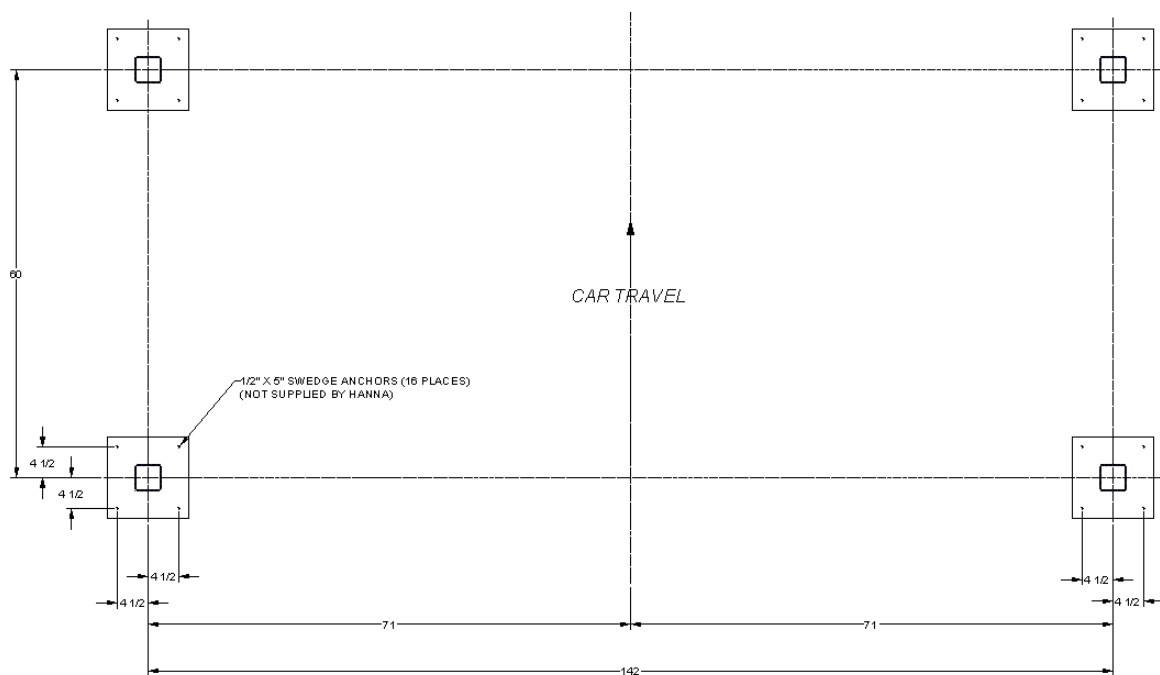

**Figure 3-6. Centerline Orientation of the Hanna Finishing Touch Mitter**

13. Once situated, drill the pilot holes for the anchor bolts, drive the 1/2" X 5" anchor bolts into the ground, tighten the nuts, and grind off the excess threads extruding from the ground.



**Figure 3-7. Anchor Bolt**

14. Re-check and make sure that all bolts are completely tight after the structure has been moved and anchored down.

### 3.5 Water Connections

This section covers the needed water connections to assure proper volume and pressure levels are met to operate this component.

15. There are two manifolds mounted on the FTM to wet the curtains down upon automobile entry. Each manifold requires a **flow of 6 GPM** at a **pressure of 40 PSI**.

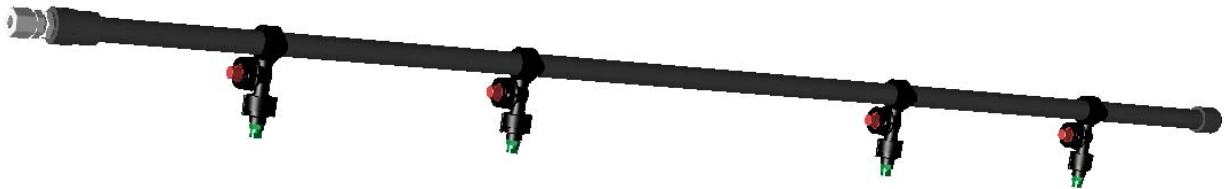

**Figure 3-8. Spray Manifold**

16. Connect ½" poly flow to the nylon fitting located at the end of the manifold. This poly must connect to the ½" valve assembly that comes with the FTM assembly.

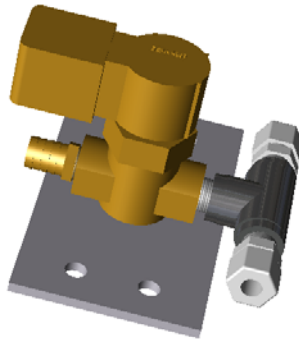

**Figure 3-9. Valve Assembly**

17. The FTM requires the use of a pumping station to feed the water to the solenoid/manifolds. Make sure that you are meeting the flow and pressure requirements to properly run the manifold. If pressure and flow are not met to engineering specifications, the cloth saturation level will not allow for quality car washing.

### 3.6 Hydraulic Connections

This section covers the hydraulic requirements and connections needed to operate the Hanna Finishing Touch Mitter.

18. A **3.0 GPM flow rate** at a pressure of **400 - 500 PSI** is required out of one priority valve from the hydraulic unit. **30-35 RPM** is the recommended rotation speed of the motor, which is established from the priority valve on the hydraulic unit.
19. The **outlet pressure should be 200 – 300 PSI** with a **pressure drop of approximately 200 PSI**.
20. One end of the motor will have the hydraulic feed line, and the other end of the motor will have the return hydraulic line. See figure 3-10 to see what these motor ports look like on the FTM.

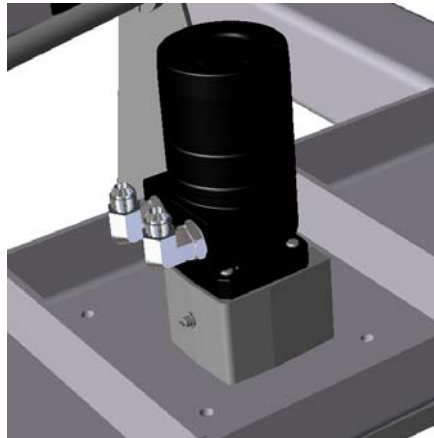

**Figure 3-10.** *Hydraulic Motor on the FTM*

21. Install all hydraulic lines and fittings. Be sure to properly install Triple-Loc fittings by tightening by hand first then using the wrench make one full turn then an additional  $\frac{3}{4}$  turn.

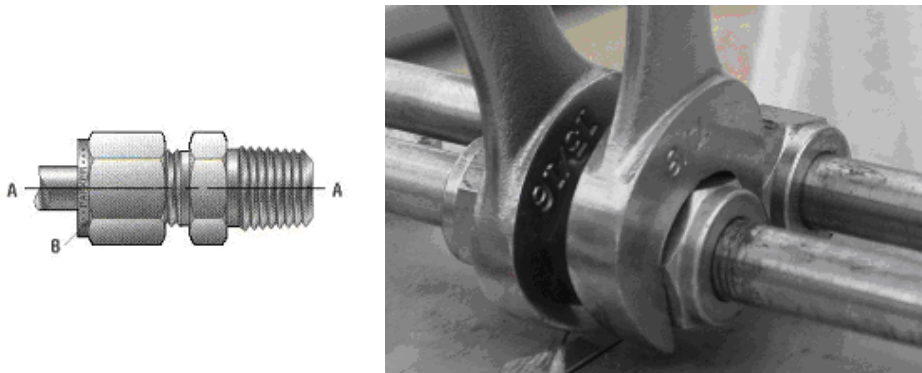

**Figure 3-11.** *Tightening the Triple-Loc Fitting*

22. Connect hydraulic lines (both pressure and return) from your mitter to your Hydraulic Power unit.
23. Connect (electrically) the hydraulic solenoid (provided with the hydraulic unit) and the water solenoid to the car wash controller.
24. The return port on the manifold will be connected to the priority valve. This priority valve is crucial in smoothing the rotational movement of the hydraulic motor shaft.

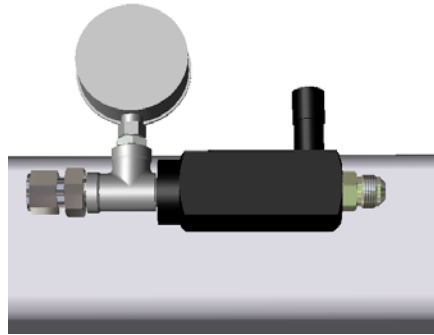

**Figure 3-12. Priority Valve Assembly**

25. When adjusting for the first time, set the PCM valve to the open position as shown.

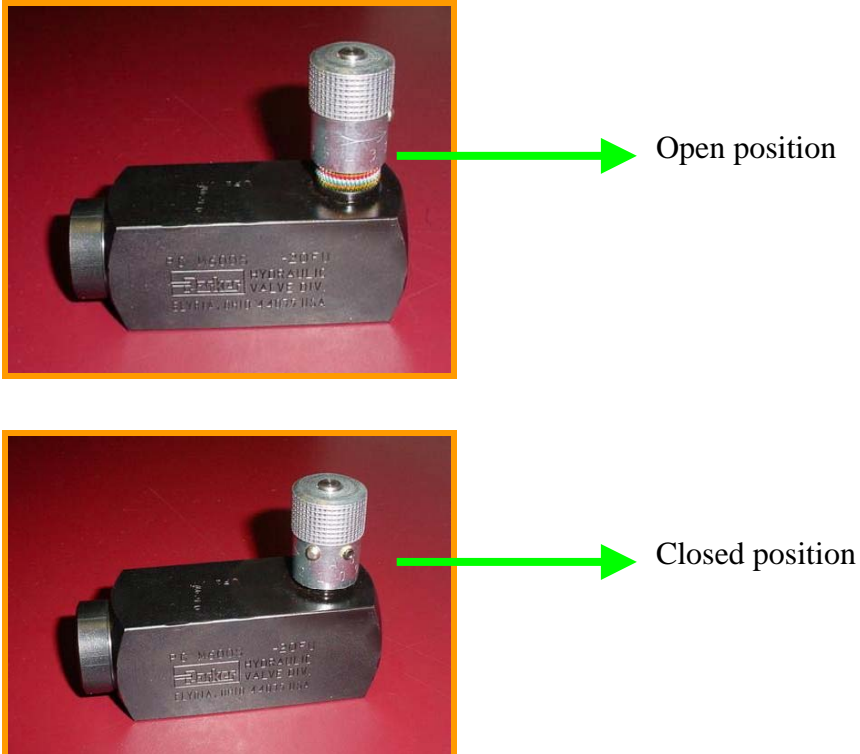

**Figure 3-13. Open and Close Position of the PCM Valve**

26. Set motor rotation speed at 30-35 RPM as recommended. This can be accomplished by adjusting the priority valve on the fixed hydraulic unit.

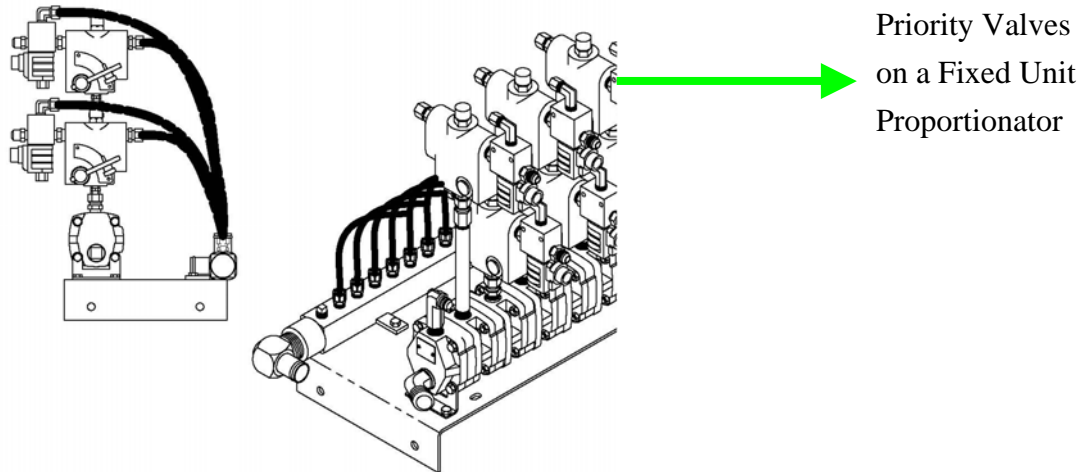
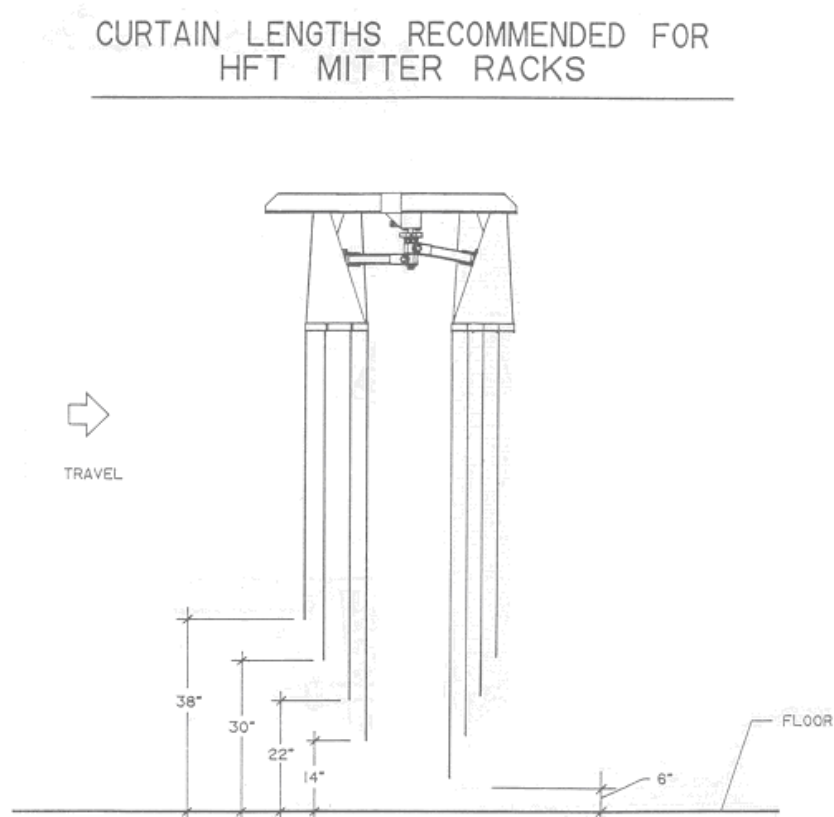

**Figure 3-14. Priority Valve Adjustment on the Proportionator**

27. Re-adjust the priority valve as necessary by slowly closing the knob for smoother rotational motion. The average flow of the priority valve should be set around 3 gallons per minute at a minimum pressure drop of approximately 200 PSI.
28. Do NOT install the curtains at this time.
29. Operate the mitter without curtains. Start the hydraulic flow slowly, and gradually increase flow until operating speed is reached. Motor speed should be 30 to 35 revolutions per minute (RPM).
30. Check for hydraulic leaks and smooth operation.

### 3.7 Installing the Curtains

31. Install curtains as displayed in the diagram below. One mitter clip is used on each six-inch-wide piece of cloth.
32. Curtain levels should be staggered by 8-inch increments. Since the exit basket in the figure below starts at 6 inches, the next three curtain levels should be at 14, 22, and 30 inches.



**Figure 3-15. Staggered Cloth Lengths on the FTM**

33. Operate the mitter with curtains installed. Start the hydraulic flow slowly and gradually increase flow until operating speed is reached. Motor speed should be 30 to 35 RPM.
34. Check for smooth operation.

### 3.8 Hanna Hydraulic Tubing Color Code

Hanna uses colored tape on all hydraulic tubing at the factory. Figure 3-14 shows the color code on all Hanna hydraulic operated equipment.



# HANNA

HYDRAULIC TUBING COLOR CODE		
EQUIPMENT	COLOR CODE	
Pressure Line	1 Stripe	
Return Line	2 Stripes	
Wraparound 98-C or Flex	Black	
Tire Washer	Brown	
HCRP	White	
Auto Prep	Purple	
SHWW or ASWW	Green	
Mitter Any Model	Blue	
Top Washer or Any Mitter	Yellow	
<b>SPARE COLORS</b>		
Also Code the Following:		
Superwave, High PSI Arch	Red	
and Any 2nd Brush in Syst.	Orange	
<b>Multi Equipment Combo's</b>		
1st Mitter in System	Blue	
2nd Mitter	Yellow	
3rd Mitter	Red	
1st ASWW in System	Green	
2nd ASWW	Orange	
3rd ASWW	Red	

Figure 3-16. Hydraulic Color Coding



This page intentionally left blank.

## **4.0 Parts and Maintenance**

### **4.1 General Maintenance**

The Hanna FTM requires periodic inspection and maintenance. However, there are only a few items that should be inspected on a regular basis. For the first month of operation check, on a weekly basis, hardware for tightness on crank arms, tie rods, bearings, vertical-mount legs, anchor bolts, stop collars, and motor mounts.

#### **4.1.1 Daily Maintenance**

- ✓ Check the curtains for tears in the cloth (if any curtain is torn correct this by cutting the torn portion out in a “half moon” shape cut)
- ✓ Check the unit for proper operation prior to washing the first vehicle each day
- ✓ Check spray nozzles for proper delivery of water on the curtains
- ✓ Check hydraulic lines for leaks

#### **4.1.2 Weekly Maintenance**

- ✓ Check water solenoid valve for positive on/off operation
- ✓ Check alignment of curtain basket
- ✓ Check tie rod alignment
- ✓ Check tie-rod bearings for proper vertical alignment

### 4.1.3 Monthly Maintenance

- ✓ Check hydraulic lines and water hoses for wear or rub
- ✓ Check frame, legs, and cross beams for cleanliness
- ✓ Check frame, legs, and cross beams for cracks and loose bolts
- ✓ Check spray nozzles for wear
- ✓ Check all bearings for wear

## 4.2 Lubrication

Any lubrication program is only as good as the lubricants used. So we suggest you review this information and stock up on the best lubricants available.

Table 4-1 shows you the amount of grease to use depending on your operating conditions. It is recommended that once you decide on a type of lithium grease that you stick to the same type of lithium grease when you lubricate your bearings.

Weekly: Lubricate bearings using high-quality multi-purpose lithium grease.

**Table 4-1 Grease Application Conditions**

Operating Conditions	Grease Supply (gf)
Normal	0.6
Minor Dust	1.2
Considerable Dust	1.8

gf = grams force

### 4.3 Bearing Replacement

The Hanna FTM has four basket bearings (Figure 4-1). Hanna recommends that you replace both bearings (on any one basket) at the same time. To remove and replace a bearing:

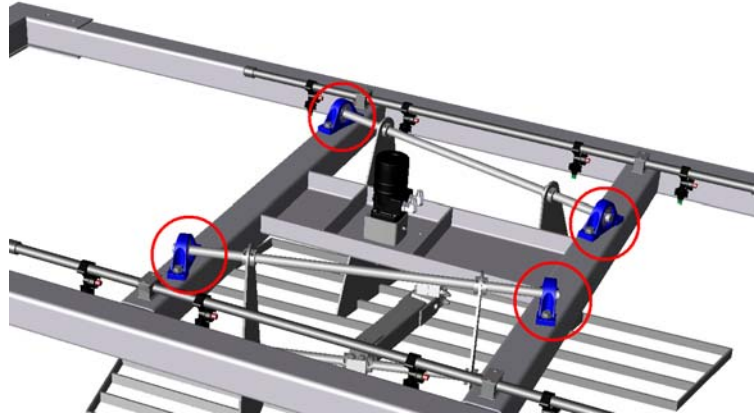

**Figure 4-1** *Top View of Basket Bearings*

1. Using a 2.5 mm. Allen wrench set loosen the adapter-locking nut located on each bearing.



**Figure 4-2** *Wrench and Adapter Locking Nut*

2. Remove the nuts, washers, and bolts that fasten the bearing housing to the structure

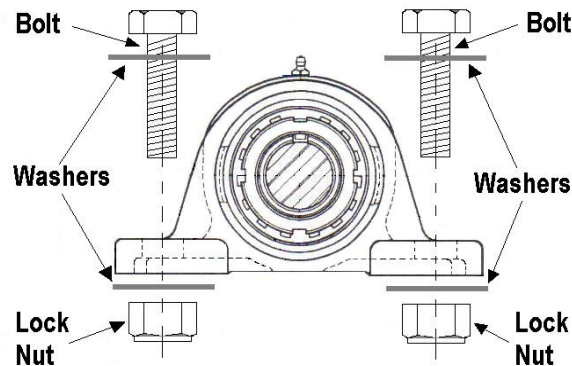

**Figure 4-3** *Bearing Housing with Nuts, Washers, and Bolts*

3. At this point you will need to remove the locking nut and loosen the adapter sleeve from the shaft. Using a dead blow hammer, hit the back side of the bearing housing to separate the sleeve from the shaft. The sleeve and bearing are taper fit.



**Figure 4-4** *Bearing at Different Assembly Stages*

4. Using a suitable and safe lift mechanism (500 lb capacity), lift the carriage assembly approximately  $\frac{1}{4}$  in. to  $\frac{1}{2}$  in. or just enough to be able to remove the old bearing.
5. Remove the bearing from the shaft.
6. Install the new bearing, with adapter sleeve insert onto the shaft.



**Figure 4-4** *Adapter Sleeve to go Over the Shaft*

7. Line up the new bearing mounting holes with the holes in the structure.
8. Insert the nuts, washers, and bolts (Figure 4-6) to attach the bearing to the structure and tighten. Use anti-sieze when attaching stainless steel hardware.

- Install the new adapter-locking nut onto the adapter and shaft making Tighten the locking nut but do not over tighten as this will damage the cone and/or the shaft. Make sure the black part face of the nut is facing outward and the metallic face of the nut is pointing towards the bearing.



Figure 4-5 Adapter Nut Secured on the Adapter Sleeve

- Lubricate the bearing with high-quality lithium grease.
- Repeat these steps to replace the bearing on the other side of the basket.

#### 4.4 Spare Parts List

Table 4-2 shows the recommended spare parts to be kept on hand by the Distributor and Owner/Operator.

Table 4-2 Recommended Spare Parts List

Recommended Parts	Part Number	Distributor Carries Part In Stock	Owner/Operator <sup>1</sup> (Distributor Support) Carries Part In Stock	Owner/Operator <sup>2</sup> (No Distributor Support) Carries Part In Stock
Clip, Mitter Curtain	805469	YES	NO	YES
Curtain, 6 in.x102 in.	759803	YES	NO	YES
Motor, Hydraulic For Fixed Displacement Units	367981	YES	NO	YES
Bearing	367457	YES	NO	YES
Jet, Nylon	363262	YES	NO	YES

- Recommends what spare parts should be kept on hand by the Car Wash Owner/Operator if there is close support from the distributor and parts are quickly obtainable.
- Recommends what spare parts should be kept on hand by the Car Wash Owner/Operator if there is NOT close support from the distributor and parts are NOT quickly obtainable.

### 4.5 Catalog of Replacement Parts Used on the Hanna FTM

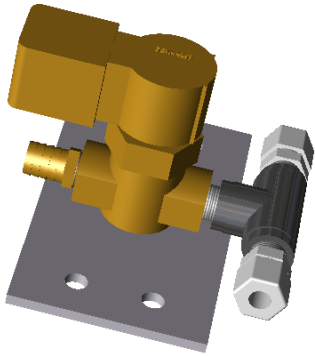

813944 – ½" Valve Assembly

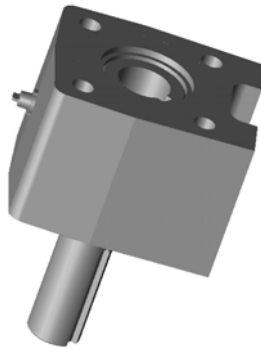

367085 – Overhung Load Adapter



367981 – Hydraulic Motor



367457 – Bearing with Adapter

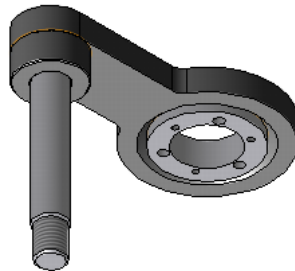

811879 – Crank Arm Weldment



367203 – Bushing QD-SH 1"

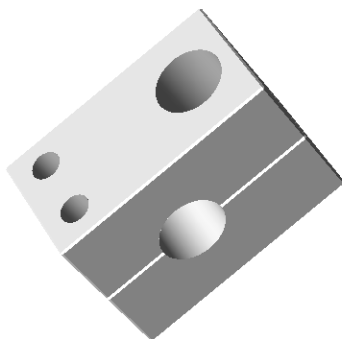

812355 – Rack Bearing

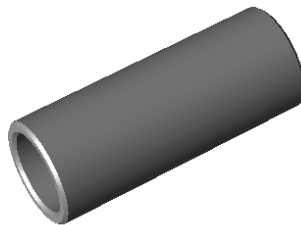

812362 – Bushing Tube

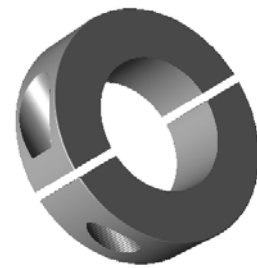

367803 – 1" Set Collar



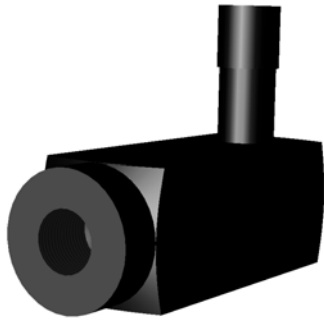

197830 – Flow Control Valve



070292 – 2000 PSI ¼" Gauge

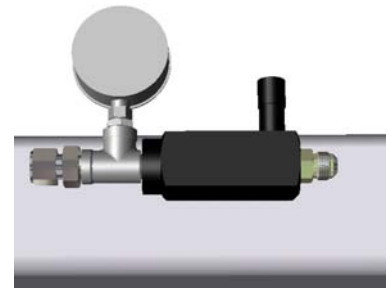

Priority Valve Assembly



812378 – Spray Manifold Assembly

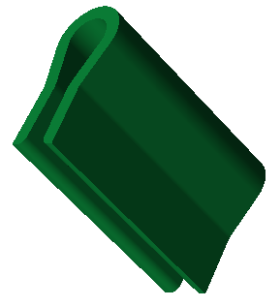

805469 – Mitter Clip

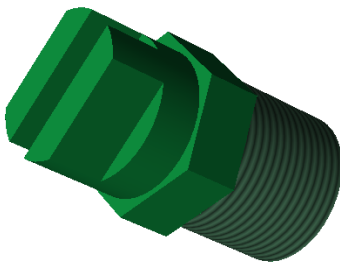

363262 – Nylon V-Jet



363377 – Cap Nozzle with Gasket



365589 – ¾" Nozzle Body

This page intentionally left blank.

## 5.0 Troubleshooting

This chapter helps you solve common mitter problems. If you are still unable to find a solution after reading through this section, please call your distributor for technical assistance.

### 5.1 Mitter Problems

<u>Problem</u>	<u>Possible Solutions</u>
<ul style="list-style-type: none"> <li>▪ BINDING OR JUMPING</li> </ul>	<ul style="list-style-type: none"> <li>▪ Check bearings for wear</li> <li>▪ Check shaft for alignment</li> <li>▪ Check crank arms for wear</li> <li>▪ Check primary drive motor</li> <li>▪ Check back-pressure relief valve</li> </ul>
<ul style="list-style-type: none"> <li>▪ UNIT WILL NOT – STOP/START</li> </ul>	<ul style="list-style-type: none"> <li>▪ Check hydraulic solenoid valve</li> <li>▪ Check computer functions</li> <li>▪ Check hydraulic motor</li> </ul>
<ul style="list-style-type: none"> <li>▪ WATER WILL NOT SHUT-OFF</li> </ul>	<ul style="list-style-type: none"> <li>▪ Check water solenoid valve for sticking</li> <li>▪ Check for contamination in solenoid valve</li> </ul>
<ul style="list-style-type: none"> <li>▪ SQUEAKING</li> </ul>	<ul style="list-style-type: none"> <li>▪ Apply grease to bearings</li> </ul>

## 5.2 Hydraulic Fitting Problems

<ul style="list-style-type: none"> <li>▪ TUBE NUT CONTINUES TO BACK OFF OR LOOSEN</li> </ul>	<ul style="list-style-type: none"> <li>▪ Excessive vibration can cause the 37° tube flare nut to back off from the fitting body. Consider better tube line routing and clamping to protect the fitting/tube union or control the system vibration.</li> </ul>
<ul style="list-style-type: none"> <li>▪ FLARE ON TUBE FITTING IS COLLAPSED</li> </ul>	<ul style="list-style-type: none"> <li>▪ 37° fittings are susceptible to over torque. Once the tube fitting has been over torqued the sealing capability is nearly gone. Additional tightening on the tube/hose joint will only cause additional leakage. Replace fitting and retighten with appropriate torque or FFWR method.</li> </ul>
<ul style="list-style-type: none"> <li>▪ DAMAGED FITTING</li> </ul>	<ul style="list-style-type: none"> <li>▪ Due to repeated use, abuse, handling, etc., the 37° flare fittings are susceptible to damage on the flare end of the fitting. These problems can often be avoided by proper handling and storage, including keeping plastic fitting caps and plugs on until fitting is used.</li> </ul>
<ul style="list-style-type: none"> <li>▪ POCK MARKS ON FLARE I.D.</li> </ul>	<ul style="list-style-type: none"> <li>▪ Tube end not deburred or cleaned properly before flaring.</li> </ul>
<ul style="list-style-type: none"> <li>▪ LEAKAGE – TUBE MISALIGNMENT OR IMPROPER FIT</li> </ul>	<ul style="list-style-type: none"> <li>▪ Align the flared tube end and the connecting tube fitting before tightening the tube nut. Ensure that the tubing is bent to the appropriate bend angles. Do not “force” the tube assembly into position. Use two wrenches during assembly.</li> </ul>
<ul style="list-style-type: none"> <li>▪ LEAKAGE – IMPROPER TIGHTENING</li> </ul>	<ul style="list-style-type: none"> <li>▪ Check the joint for appropriate tightness. Re-torque or use the FFWR method of assembly to ensure appropriate joint makeup. If leakage persists, it could be a problem listed below.</li> </ul>

<ul style="list-style-type: none"> <li>▪ LEAKAGE – TUBE CRACKED ALONG FLARE</li> </ul>	<ul style="list-style-type: none"> <li>▪ Poor quality tube, work-hardened tube, or faulty tube preparation can cause the tube to crack. Re-flare while addressing the aforementioned issues. Do not use a tube cutter with steel and stainless steel tube, as tube cutters tend to “work harden” the tube before flaring.</li> </ul>
<ul style="list-style-type: none"> <li>▪ LEAKAGE – TUBE SEALING SURFACE HAS IMPERFECTION CAUSING LEAKAGE BETWEEN TUBE FITTING AND TUBE FLARE</li> </ul>	<ul style="list-style-type: none"> <li>▪ Low quality welding tube often will leave a weld bead causing a leak path between the fitting and tube flare. Use a high-quality seamless or welded and redrawn type of tube. Problems with the flaring tooling can also cause a surface imperfection on the sealing surface of the tube flare as well. Flare cones/burnishing heads, when damaged can cause these imperfections in the mating tube flare. Re-flare while addressing the aforementioned problem areas.</li> </ul>

This page intentionally left blank.



**Jim Coleman Company/Hanna Car Wash Systems**

*Main Office*

5842 West 34<sup>th</sup> Street  
Houston, TX 77092

800-999-9878 • 713-683-9878 • Fax: 713-683-9624  
[www.jcolemanco.com](http://www.jcolemanco.com)

*Hanna Division Office*

7905 Blankenship Dr.  
Houston, TX 77055

866-683-6615 • 713-683-6615 • Fax: 713-590-6630  
[www.hannacarwash.com](http://www.hannacarwash.com)



**Jim Coleman Company/Hanna Car Wash Systems**

*Main Office*

5842 West 34<sup>th</sup> Street  
Houston, TX 77092

800-999-9878 • 713-683-9878 • Fax: 713-683-9624  
[www.jcolemanco.com](http://www.jcolemanco.com)

*Hanna Division Office*

7905 Blankenship Dr.  
Houston, TX 77055

866-683-6615 • 713-683-6615 • Fax: 713-590-6630  
[www.hannacarwash.com](http://www.hannacarwash.com)