

# Diagonal Touch Mitter

## *Service Manual*

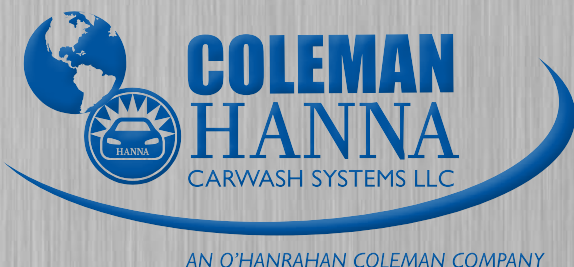

5842 W 34th St, Houston, TX 77092  
1.800.999.9878 • 1.713.683.9878  
[www.colemanhanna.com](http://www.colemanhanna.com)



Find us on Facebook:  
[/ColemanHannaCarwash](https://www.facebook.com/ColemanHannaCarwash)

## Copyrights

A-LOK is a registered trademark of Parker Hannifin Corporation.

TRIM is a registered trademark of Master Chemical Corporation.

# Table of Contents

- 1.0 INTRODUCTION..... 1-1**
  - 1.1 Design Features..... 1-2
  - 1.2 Basic Operation..... 1-2
  
- 2.0 SAFETY ..... 2-1**
  - 2.1 Cautions, Warnings, and Notes..... 2-2
    - 2.1.1 Cautions ..... 2-2
    - 2.1.2 Warnings..... 2-2
    - 2.1.3 Notes ..... 2-2
  
- 3.0 WARRANTY INFORMATION ..... 3-1**
  - 3.1 Distributor/Customer Delivery Acceptance..... 3-1
    - 3.1.1 Piece Count ..... 3-1
    - 3.1.2 Damage ..... 3-1
  - 3.2 Filing Freight Claims ..... 3-1
  - 3.3 Pre-Installation..... 3-2
  - 3.4 Hanna Warranty Claim Procedure ..... 3-2
  
- 4.0 INSTALLATION ..... 4-1**
  - 4.1 Installation Requirements ..... 4-1
  - 4.2 General Requirements..... 4-1
  - 4.3 Installation..... 4-2
  - 4.4 Hydraulic Fitting Assembly and Remake (A-LOK™) for  
Pressure Compensated Hydraulic Power Units ..... 4-4
  - 4.5 Hydraulic Fitting Torque (Triple-LOK™) for  
Fixed Displacement Hydraulic Power Units..... 4-6
  - 4.6 Hanna Hydraulic Tubing Color Code..... 4-7
  
- 5.0 PARTS AND MAINTENANCE..... 5-1**
  - 5.1 General Maintenance ..... 5-1
    - 5.1.1 Daily Maintenance ..... 5-1
    - 5.1.2 Weekly Maintenance ..... 5-1
    - 5.1.3 Monthly Maintenance ..... 5-1

5.2 Lubrication of Bearings ..... 5-2

5.3 Bearing Replacement ..... 5-3

5.4 Spare Parts List ..... 5-8

5.5 Recommended Tool Kit..... 5-9

5.6 Replacement Parts..... 5-9

**6.0 TROUBLESHOOTING..... 6-1**

6.1 Mitter Problems ..... 6-1

6.2 Hydraulic Fitting Problems..... 6-2

**APPENDIX A ..... A-1**

## Table of Figures

Figure 1-1. Hanna XT Diagonal Touch Mitter ..... 1-1

Figure 4-1 A-LOK Fitting Remake..... 4-5

Figure 4-2 Hanna Hydraulic Tubing Color Code ..... 4-7

Figure 5-1 Top View of Basket Bearings ..... 5-3

Figure 5-2 Bearing Tab Slot Location ..... 5-3

Figure 5-3 Bearing Housing with Nuts, Washers, and Bolts..... 5-4

Figure 5-4 Bearing Assembly ..... 5-4

Figure 5-5 Bearing Assembly ..... 5-5

Figure 5-6 Bearing Housing with Nuts, Washers, and Bolts..... 5-5

Figure 5-7 Bearing with Castle Washer and Cone..... 5-6

Figure 5-8 Bearing Spanner Nut..... 5-6

Figure 5-9 Castle Washer Tab Slot..... 5-7

# 1.0 Introduction

The new Hanna XT Diagonal Touch Mitter (XT DTM) represents the next generation of Hanna developed and Hanna tested car wash systems. This side-supported stainless-steel mitter offers superior cleaning while gently washing all types and shaped of vehicles. One stainless steel basket, containing 40 curtains, concentrates cleaning motion to the horizontal surfaces of the vehicle and also provides some cleaning motion to the side vertical surfaces. The XT Diagonal Touch Mitter (Figure 1-1) is especially suited for shorter tunnel washes where space is at a premium.

The XT series of mitters is part of the new Hanna XT modular structure and offers the car wash owner a new option to provide top service and reliability to their customers at an affordable cost. The XT DTM is also available as a freestanding option.

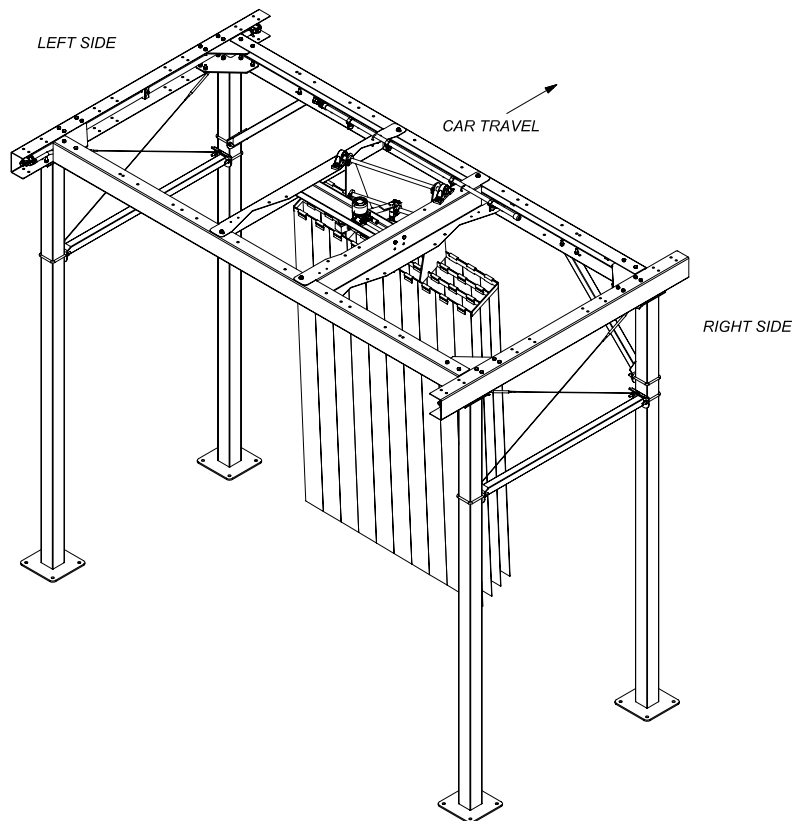

Figure 1-1. Hanna XT Diagonal Touch Mitter

## 1.1 Design Features

The cloth panels that attach to the mitter rack are manufactured of a mixture of polyethylene and nylon copolymer fibers needled together. The cloth has a fuzzy aggressive texture. There is one stainless steel curtain basket with a total of 40 curtains.

The mitter basket exhibits angled horizontal movement (back and forth) in the direction of vehicle travel. The angled motion contributes greatly to provide superior cleaning on the top and sides of vehicles. The XT DTM utilizes a direct-drive hydraulic motor. This drive offers the flexibility of variable-speed adjustments. This combination of a variable speed (by adjusting the hydraulic valve) motor, multi-textured wash material, and staggered curtain length, produce the most effective cleaning mitter in the industry.

## 1.2 Basic Operation

The XT DTM is designed to activate as a vehicle approaches and shut off as the vehicle moves past the mitter curtain. This is accomplished with a hydraulic solenoid valve on the hydraulic power unit. Water to wet down the curtains is activated by a solenoid valve and can be fresh water or reclaim.

The angled stainless steel basket moves diagonally (back and forth) to give superior cleaning of the horizontal surfaces of a vehicle. The forward and backward motion gently cleans the vehicle as the soft cloth conforms to the vehicle's shape without incident to the roof racks, lights, and antennas.

## 2.0 Safety

Keep the following safety rules in mind when installing and using Hanna Car Wash Systems Equipment:

**NOTE:** *Always follow local and national trade codes when installing any equipment.*

- Always disconnect power from any electrical device or component prior to servicing.
- Unplug the unit or use proper lockout procedures so that no one can inadvertently turn the power on while you are working on that equipment.
- Always power down the control box before unplugging or plugging in quick disconnects.
- Use caution when maintaining any piece of equipment.
- Wear protective clothing and eyewear when using power tools.
- Direct discharge of high-pressure water and chemicals away from you and other persons, or direct it into approved containers.
- Keep equipment clean for proper operation.
- Keep hands or any body parts away from equipment while in operation.
- If you need to disassemble a part for service or repair, re-assemble equipment according to instructions.
- Be sure all components are firmly screwed or latched into position.
- Observe safety and handling instructions of the chemical manufacturers.
- Wear protective clothing and eyewear when dispensing or working with chemicals or other potentially hazardous materials.

## 2.1 Cautions, Warnings, and Notes

Throughout this manual, there are various messages concerning safety – please heed these warnings! The following sections give some examples of these safety messages.

### 2.1.1 Cautions

Cautions warn against a potential hazard that, if not avoided, may result in minor or moderate injury. Caution signs also alert against unsafe practices that may cause property damage.



**CAUTION: *DO NOT TOUCH THE BLUE BUTTON! IT IS THE SYSTEM BUTTON AND USED FOR CONFIGURATION.***

### 2.1.2 Warnings

Warning messages warn against a potential hazard that, if not avoided, may result in serious injury or death.



**WARNING: *DO NOT REMOVE PLUGS UNDER ELECTRICAL POWER. MAIN ELECTRICAL POWER MUST BE SHUT OFF BEFORE DISCONNECTING OR CONNECTING ANY PLUG OR CABLE ON THE SPRAY HEAD.***

### 2.1.3 Notes

Note means reader take note. Notes contain helpful suggestions.

**NOTE:** *This parameter should NOT be changed when attempting to make system adjustments.*



## 3.0 Warranty Information

### 3.1 Distributor/Customer Delivery Acceptance

Before signing for delivery, the distributor/customer must check the equipment for piece count and damage.

#### 3.1.1 Piece Count

Every packing list has the total number of pieces shipped from Hanna. The number of pieces will vary, but is usually between 1 and 20. Check the bill and count the pieces on the load. Be aware that several large items will only count as one piece if they are banded together. Any discrepancies (shortages) in piece count must be clearly noted on the Bill of Lading.

The installing distributor/customer has 14 days from receipt of the equipment to report any shortages to Jim Coleman Company/Hanna (JCC/H). Because of this time frame, it is important to take a COMPLETE inventory as soon as possible.

#### 3.1.2 Damage

Inspect the load thoroughly before unloading, and make note of any visible damage on the bill of lading before you sign it. This will help later if a freight damage claim is filed against the freight carrier. Remember that the freight carrier is responsible for any damage during transit. Hidden damage may show up later as you uncrate equipment. If so, notify the freight company's nearest office as soon as possible.

### 3.2 Filing Freight Claims

If damage is discovered during uncrating, immediately call the freight carrier's nearest office for an onsite inspection of damage. Do not throw any crating materials away, save them for the carrier's representative to inspect. To recover damages, mail copies of the carrier's claim form, the invoice for repairs, the delivery receipt, and the inspection report to the carrier within 90 days of the delivery date.

### 3.3 Pre-Installation

Look for the crates with “Hardware Kit” or “Manuals” stenciled on the sides. These are the only two crates that you want to open immediately. The Hardware Kit provides all the bolts, washers, and nuts that you will need to bolt the equipment together. The manuals and drawings will cover installation, assembly, parts identification, and operation.

At the time of startup, be sure to complete form 1111, “Hanna Start-up Review and Warranty Report” (page 3-5) and return it to:

**Jim Coleman Company/Hanna**  
**Attn: Quality Systems Manager**  
**7905 Blankenship Drive**  
**Houston, TX 77055**

This report is essential to both Hanna and the distributor. It helps Hanna to review the initial start-up procedures and settings, and it validates the warranty period. This is very important, as no warranty will be allowed until this form is on file at Hanna.

**NOTE:** *Please be sure to keep a copy of this form for your records.*

### 3.4 Hanna Warranty Claim Procedure

1. Owner/Customer notifies installer/distributor of warranty claim.
2. Installer/distributor notifies Hanna Quality Systems of a claim.
3. Warranty/Quality Representative at Hanna:
  - Reviews Hanna files to determine applicable warranty period.
  - Discusses with distributor/customer possible reasons for component failure.
  - Issues an order for shipment of a replacement part (as appropriate).
  - Issues a Returned Goods Authorization (RGA) number.
  - Transmits by fax a copy of the RGA and replacement order confirmation to the distributor.

- Attaches a copy of the RGA to the replacement order and sends it to Manufacturing for shipment. Warranty shipments from Hanna will be PREPAID for ground transportation only (UPS-Ground, truck, etc.). All forms of quick shipments will be at the expense of the distributor or customer.
  - Distributor/customer submits prepayment via credit card or check prior to shipment of replacement part. Upon acceptance of warranty claim, Hanna will reimburse distributor/customer for prepayment (see steps number 5 and 6 below for claim processing procedures).
4. The distributor/customer, upon receiving the replacement part, will:
    - Add comments to the RGA included with the shipping ticket to further clarify the problem with the proposed warranted part.
    - Ship the defective part and the RGA to Hanna within 30 days, freight PREPAID.
    - Be sure that the RGA number is plainly visible on the package exterior.
  5. The returned part, when received at Hanna, will be logged as received and inspected for validity of claim.
    - If the part is a Hanna manufactured part, evaluation, will be completed within five working days.
    - If the part is a vendor item, evaluation may take up to 45 days or more.
  6. When evaluation is completed, a Hanna Warranty/Quality representative will contact the distributor/customer and notify them if their claim has been accepted or rejected.
    - If the warranty claim is rejected, evaluation reports and reason for rejection will be sent. Distributor/customer may elect to have the parts discarded or returned to them freight collect.
    - If the warranty claim is accepted, an appropriate credit will be given to the distributor/customer.
  7. We at Hanna are dedicated to assisting our distributors/customers. Valid warranty claims are welcome. However, parts returned without pre-authorization and/or without a RGA number will not be accepted. We cannot accept shipments that are sent other than freight PREPAID.

This page intentionally left blank.

**HANNA WARRANTY START-UP REVIEW / CONVEYORIZED SYSTEM**

Hanna Distributor \_\_\_\_\_ Equipment Order # \_\_\_\_\_  
 Car Wash Name \_\_\_\_\_  
 Owner's Name \_\_\_\_\_ Phone \_\_\_\_\_  
 Address \_\_\_\_\_  
 Type of Equipment \_\_\_\_\_

	YES	NO		YES	NO
<b>CORRELATOR</b>			<b>TIRE WASHERS</b>		
Top plate moves freely both ways	<input type="checkbox"/>	<input type="checkbox"/>	Proper brush height	<input type="checkbox"/>	<input type="checkbox"/>
Guide Rails move freely	<input type="checkbox"/>	<input type="checkbox"/>	Base plates level	<input type="checkbox"/>	<input type="checkbox"/>
<b>CONVEYOR</b>			CTA treadles as per specs	<input type="checkbox"/>	<input type="checkbox"/>
Conveyor Speed – cars per hour	<input type="checkbox"/>	<input type="checkbox"/>	Treadles operating freely	<input type="checkbox"/>	<input type="checkbox"/>
Chain tension set to specs	<input type="checkbox"/>	<input type="checkbox"/>	Spring tension set to specs	<input type="checkbox"/>	<input type="checkbox"/>
Shipping nut removed (RCV)	<input type="checkbox"/>	<input type="checkbox"/>	Speed set to specs	<input type="checkbox"/>	<input type="checkbox"/>
Roller-up forks adjusted to specs	<input type="checkbox"/>	<input type="checkbox"/>	<b>MITTERS</b>		
Fork cylinder moves smoothly	<input type="checkbox"/>	<input type="checkbox"/>	Curtain RPM set to specs	<input type="checkbox"/>	<input type="checkbox"/>
Air/oil pressure adjusted to specs	<input type="checkbox"/>	<input type="checkbox"/>	Curtains installed & trimmed properly	<input type="checkbox"/>	<input type="checkbox"/>
Cancel switch properly located	<input type="checkbox"/>	<input type="checkbox"/>	Basket movements smooth	<input type="checkbox"/>	<input type="checkbox"/>
Trap doors move freely	<input type="checkbox"/>	<input type="checkbox"/>	Sufficient water on curtains	<input type="checkbox"/>	<input type="checkbox"/>
Welds between sections ground smooth	<input type="checkbox"/>	<input type="checkbox"/>	All bearings lubricated	<input type="checkbox"/>	<input type="checkbox"/>
Conveyor hydraulic connections tight	<input type="checkbox"/>	<input type="checkbox"/>	<b>AIR DRYER</b>		
<b>HYDRAULIC SYSTEM</b>			Type/Model of air dryer _____		
All fittings/lines clean & tight	<input type="checkbox"/>	<input type="checkbox"/>	Supply voltage and phasing _____		
Oil in tank above "low-level" control	<input type="checkbox"/>	<input type="checkbox"/>	Amp draw on phase legs _____		
Low-level control switch operating	<input type="checkbox"/>	<input type="checkbox"/>	Size of thermals/breakers _____		
Approved "EP" hydraulic oil used	<input type="checkbox"/>	<input type="checkbox"/>	MCC provided by HCW	<input type="checkbox"/>	<input type="checkbox"/>
<b>RECLAIM SYSTEM</b>			Checked for proper impeller rotations	<input type="checkbox"/>	<input type="checkbox"/>
Suction line piping clean and tight	<input type="checkbox"/>	<input type="checkbox"/>	Motors protected from direct water	<input type="checkbox"/>	<input type="checkbox"/>
Discharge piping clean and tight	<input type="checkbox"/>	<input type="checkbox"/>	Intakes protected and unobstructed	<input type="checkbox"/>	<input type="checkbox"/>
Relief bypass valve free to operate	<input type="checkbox"/>	<input type="checkbox"/>	Cone linkage moves freely	<input type="checkbox"/>	<input type="checkbox"/>
Pits free of oil and floating debris	<input type="checkbox"/>	<input type="checkbox"/>	Checked for leaks and unusual noises	<input type="checkbox"/>	<input type="checkbox"/>
Barrel screen and foot valve clean	<input type="checkbox"/>	<input type="checkbox"/>	All bearings lubricated	<input type="checkbox"/>	<input type="checkbox"/>
Inlets to pits unobstructed	<input type="checkbox"/>	<input type="checkbox"/>	<b>COMMON AIR SYSTEM</b>		
<b>CHEMICAL FEED UNIT</b>			Excessive water in air system lines	<input type="checkbox"/>	<input type="checkbox"/>
Air pressure set at 55-60 PSI	<input type="checkbox"/>	<input type="checkbox"/>	Proper oilers installed	<input type="checkbox"/>	<input type="checkbox"/>
Water pressure set at 50-58 PSI	<input type="checkbox"/>	<input type="checkbox"/>	Normal system pressure set at 120 psi	<input type="checkbox"/>	<input type="checkbox"/>
All fittings at pump tight and leak-free	<input type="checkbox"/>	<input type="checkbox"/>	<b>COMPUTER</b>		
All line fittings tight and leak-free	<input type="checkbox"/>	<input type="checkbox"/>	Computer type/model _____		
All intake lines free from kinks	<input type="checkbox"/>	<input type="checkbox"/>	EPROM chip version number _____		
<b>ARCHES</b>			<b>REPAIRS &amp; ADJUSTMENTS</b>		
All jets aimed according to specs	<input type="checkbox"/>	<input type="checkbox"/>	_____		
Actuators operating to specs	<input type="checkbox"/>	<input type="checkbox"/>	_____		
Air pressures set to specs	<input type="checkbox"/>	<input type="checkbox"/>	_____		
Foamer – is there adequate foam	<input type="checkbox"/>	<input type="checkbox"/>	<b>COMMENTS</b>		
Spray wax operating to specs	<input type="checkbox"/>	<input type="checkbox"/>	_____		
Polish wax operating to specs	<input type="checkbox"/>	<input type="checkbox"/>	_____		
Rinse functioning with drying agent	<input type="checkbox"/>	<input type="checkbox"/>	_____		
Final rinse provides complete coverage	<input type="checkbox"/>	<input type="checkbox"/>	<b>CUSTOMER ACCEPTANCE:</b> Owner acknowledges		
<b>BRUSHES</b>			they have received instruction for proper equipment		
Correct rotation directions	<input type="checkbox"/>	<input type="checkbox"/>	operation & received a full set of manuals.		
Brush RPM set to specs	<input type="checkbox"/>	<input type="checkbox"/>	<b>OWNER:</b> _____		
Proper brush penetration	<input type="checkbox"/>	<input type="checkbox"/>	Signature: _____		
Shocks functioning properly	<input type="checkbox"/>	<input type="checkbox"/>			
All couplings and flanges tight	<input type="checkbox"/>	<input type="checkbox"/>			
Proper water application	<input type="checkbox"/>	<input type="checkbox"/>			

HCW form 1111, 5/5/2004

This page intentionally left blank.

## LIMITED WARRANTY

The Manufacturer warrants any component or part of the Jim Coleman Company Car Wash equipment to be free from defects in material and workmanship for a period of one year from date of shipment, with the exception of such parts as are commonly recognized to be subject to wear in normal usage, such as high pressure hoses, swivels, nozzles, safety shut off guns, etc., which are warranted for ninety (90) days. All electrical parts not manufactured by Jim Coleman Company are warranted to be free from defects in material and workmanship for a period of ninety (90) days. Electrical motors shall be covered under manufacturer's warranty for a period of one year, unless otherwise specified. Jim Coleman Company electronic controls, such as timers, coin acceptors and computer monitoring equipment, carry a one-year warranty. Claims under this warranty must be asserted in writing within the one-year period covered by this warranty.

Any component or part alleged to be defective in material or workmanship shall, at option of Manufacturer be returned with shipping cost prepaid. If upon examination, such component or part is found to be defective in workmanship or materials, Manufacturer, at its option will either repair or replace such component or part and shall ship such repaired or replaced component or parts F.O.B. factory, Houston, Texas. The cost of such replacement or repair shall be the exclusive remedy for any breach of any warranty and Manufacturer shall not be liable to any person for consequential damages for injury or commercial loss resulting from any breach of any warranty. This warrant does not cover any labor installation cost, either with respect to the original equipment or with respect to the repaired or replaced component or part defective in workmanship or materials. Jim Coleman Company does not warrant loss of income, should there be any during such time repairs are being made.

This warranty does not apply to components or parts which have been misused, altered, neglected, or not installed, adjusted, maintained, or used in accordance with applicable codes and ordinances and in accordance with Manufacturer's recommendations as to such factors.

This warranty is in lieu of all warranties, express or implied, of either Manufacturer or seller, and Manufacturer makes no warranty against infringement of the like, makes no warranty of merchantability, makes no warranty of fitness for a particular purpose, and makes no other warranty, express or implied, including implied warranty arising from course of dealing or usage of trade.

This warranty does not apply to damage resulting from improper operation or abuse, exceeding the rated capacities of the unit, running foreign particles or non related solutions through pumps or valves, using acidic solutions, improper installation or maintenance, operational neglect, neglect of manufacturers recommended maintenance, use of water containing solids in excess of twenty microns in diameter or 2000 PPM, damage caused by customer, unjustifiable nuisance calls or acts of God.

Compliance with any local governmental laws or regulations relating to the location, use or operation of the equipment, its use in conjunction with other equipment, shall be the responsibility of the purchaser. The rights and obligations of the parties shall be governed by the state of Texas.

This page intentionally left blank.



**RETURNED GOODS AUTHORIZATION (RGA)**

Customer Account No.: \_\_\_\_\_  
 Customer: \_\_\_\_\_  
 \_\_\_\_\_  
 \_\_\_\_\_

Date: \_\_\_\_\_  
 Ref. Equip No.: \_\_\_\_\_  
 Ref. Sales No.: \_\_\_\_\_  
 Start Up Date: \_\_\_\_\_

**PARTS TO BE RETURNED**

Qty.	Parts #	Description	Reason For Return

Return parts, shipping PREPAID to: **Jim Coleman Company/Hanna**  
**7905 Blankenship Drive**  
**Houston, TX 77055**

**Important Note:** If the parts listed above are not received within 45 days from the date of shipment of the replacement parts from JCC/H, then credit for the returned parts will be disallowed and the invoice becomes due and immediately payable. This form **MUST** accompany ALL returned parts.

**No Form = No Credit**

-----  
 Do Not Write Below This Line. To Be Completed By Jim Coleman Company/Hanna Customer Service Department Only.  
 -----

Date Parts Received: \_\_\_\_\_  
 Disposition:  Salvage/Discard  
                    Hanna Evaluation  
                    Engineering Review  
                    Vendor Evaluation  
 Approved: \_\_\_\_\_  
 Parts Complete: \_\_\_\_\_

Checked In By: \_\_\_\_\_  
 Comments: \_\_\_\_\_  
 \_\_\_\_\_  
 \_\_\_\_\_  
 By Whom: \_\_\_\_\_  
 Credit Memo No: \_\_\_\_\_

This page intentionally left blank.

## 4.0 Installation

The following information is a suggested means for installation of the Hanna XT Diagonal Touch Mitter (XT DTM). It is understandable not all installations are the same, nor accomplished with the same ease. Therefore, many of your own ideas, experiences, and installation tricks are encouraged and should be implemented.

Prior to the actual installation an on-site visit and observations are recommended. This is especially true if the location is other than new and/or not of Hanna design. Check for the local utilities, making sure of proper access location and supply sizing. If anything must be changed, do so prior to the day of installation. Deficiencies discovered at the time of installation will greatly delay the project.

### 4.1 Installation Requirements

- Water: Customer is to provide and install a  $\frac{3}{4}$  in. water line at 60 psi (nominal).
- Hydraulic: Customer is to provide and install proper hydraulic power system.
- Dimensions:
  - Outside Height (90 in. Structure) – 10 ft. 6 in. (3.2 m)
  - Outside Height (96 in. Structure) – 11 ft. (3.35 m)
  - Outside Length (90 in. and 96 in. Structure) – 7 ft. (2.13 m)
  - Inside Clearance (90 in. Structure) – 7 ft. 6 in. (2.29 m)
  - Inside Clearance (96 in. Structure) – 8 ft. (2.44 m)
  - Outside Width (90 in. and 96 in. Structure) – 12 ft. 2 in. (3.71 m)

### 4.2 General Requirements

Before getting started, you must find the proper location for your new XT DTM. We recommend a minimum length of 7 ft. (2.13 m) clear area for proper operation. The clear area is defined as any space that allows the mitter to operate freely, but will not interfere with or is interfered with by other devices.

### 4.3 Installation

1. Read this manual prior to opening crates or installing equipment.
2. Carefully open crates and identify the individual parts for assembly using the enclosed checklist. If there are any missing parts, notify your Hanna distributor immediately (see warranty information in Chapter 3.0).



**WARNING: WHEN USING A FORKLIFT TO INSTALL EQUIPMENT MAKE SURE TO FOLLOW OSHA AND GENERAL SAFETY RULES AND REGULATIONS TO ENSURE PERSONAL SAFETY.**

3. Place the framework in the wash bay as shown on the layout drawing (Appendix A). Make sure the framework is facing the correct direction for vehicle travel. When all pieces for your configuration have been set in place, take the time to re-check all the layout dimensions using your conceptual drawing.
4. Raise the mitter frame with a fork lift or portable lift and attach the four legs as shown in the layout drawing.
5. Attach a cable bracket from the two inner legs to the frame bolts on each leg. Tighten all leg bolts.
6. Attach a tube brace on each side between the legs and attach cables. Level the brace and tighten.
7. Install the two posts to header gussets and tighten.
8. Tighten each cable assembly by hand and then tighten an additional 2 turns.
9. Make sure you have the mitter layout aligned with the centerline of your carwash system. This is very important! Centerline is 26.5 in. from the inside conveyor guide rail.
10. Anchor the support legs to the floor using 5/8 in. diameter concrete anchor bolts not less than 4-1/2 in. long.

11. Make sure the components are assembled correctly and leveled.
12. Install all hydraulic lines and fittings. Be sure to read Section 4.4 for proper installation of A-LOK fittings.



**WARNING: FAILURE OR IMPROPER SELECTION OR IMPROPER USE OF HOSE, TUBING, FITTINGS, ASSEMBLIES, OR RELATED ACCESSORIES CAN CAUSE DEATH, PERSONAL INJURY, AND PROPERTY DAMAGE.**

13. Connect hydraulic lines (both pressure and return) from your mitter to your Hydraulic Power unit.
14. Connect water lines to your water system. Connect water solenoid to manifold with provided hoses and clamps.



**WARNING: MAIN ELECTRICAL POWER MUST BE SHUT OFF BEFORE DISCONNECTING OR CONNECTING ANY PLUGS OR WIRES IN THE CONTROL BOX.**

15. Connect (electrically) the hydraulic solenoid (provided with the hydraulic unit) and the water solenoid to the car wash controller.
16. Do NOT install the curtains at this time.
17. Operate the mitter without curtains. Start the hydraulic flow slowly, and gradually increase flow until operating speed is reached. Motor speed should be 30 to 35 revolutions per minute (RPM).
18. Check for hydraulic leaks and smooth operation.
19. Install curtains as displayed in layout drawing (Appendix A). One mitter clip is used on each six-inch-wide piece of cloth.

20. Operate the mitter with curtains installed. Start the hydraulic flow slowly and gradually increase flow until operating speed is reached. Motor speed should be 30 to 35 RPM.
21. Check for smooth operation.

#### 4.4 Hydraulic Fitting Assembly and Remake (A-LOK™) for Pressure Compensated Hydraulic Power Units

Stainless Steel A-LOK (non-flared) fittings are used on Hanna's Pressure Compensated Hydraulic Power Units. These fittings consist of four precision engineered parts designed to provide secure leak-proof joints capable of handling high-pressure applications. The tube fittings are completely assembled and ready for immediate use. Simply insert the tube until it bottoms in the fitting body. (If the fitting is disassembled, note that the small tapered end of the ferrule(s) go into the fitting body.)



**WARNING: FAILURE OR IMPROPER SELECTION OR IMPROPER USE OF HOSE, TUBING, FITTINGS, ASSEMBLIES, OR RELATED ACCESSORIES CAN CAUSE DEATH, PERSONAL INJURY, AND PROPERTY DAMAGE.**

If you need to assemble the A-LOK fitting, follow these steps:

1. Tighten nut finger tight.
2. Then tighten nut (with wrench) an additional 1-1/4 turns for ¼ in. to 1 in. size fittings (6 mm to 25 mm). For 1/16 in., 1/8 in., 3/16 in., 2 mm, 3 mm, and 4 mm size tube fittings only wrench ¾ turn from finger tight position. Be sure to hold the fitting body with a second wrench to prevent body from turning. It is also helpful to mark the nut to accurately count the number of turns.
3. If you have an inspection gauge, select the proper size inspection gauge and try to place it between the nut and the body hex. If gauge does not fit at any point between them, you have correctly tightened the nut. If you can slip the gauge into the space, the fitting is not properly made up, and you must repeat the assembly procedure.
4. For maximum number of remakes, mark the fitting and nut before disassembly. Before,

retightening, make sure the assembly has been inserted into the fitting until the ferrule seals in the fitting. Retighten the nut by hand. Rotate the nut with a wrench to the original position as indicated by the previous marks lining up. (A noticeable increase in mechanical resistance will be felt indicating the ferrule is being re-sprung into sealing position.)

A disassembled joint can be remade simply by retightening the nut to the position of the original make up. If you need to remake the A-LOK fitting, follow these steps:

1. A disassembled joint can be remade simply by retightening the nut to the position of the original make up. For maximum number of remakes, mark the fitting and nut before disassembly.
2. Before retightening, make sure the assembly has been inserted into the fitting until the ferrule(s) seats in the fitting.
3. Retighten the nut by hand.
4. Rotate the nut with a wrench to the original position as indicated by the previous marks lining up. (A noticeable increase in mechanical resistance will be felt indicating the ferrule is being re-sprung into sealing position.)
5. Then tighten the nut 1/4 turn as shown from A to B (Figure 4-1), past the original position. Only after several remakes will it become necessary to advance the nut slightly past the original position.

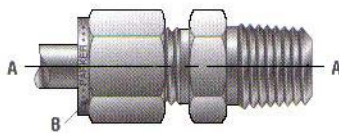

**Figure 4-1 A-LOK Fitting Remake**

**NOTE:** *A-LOK™ tube fitting part numbers use symbols to identify the size, style, and material. Tube and pipe thread sizes begin with a number indicating their size in sixteenths of an inch. For example, 4=4/16 in. or 1/4 in., 16=16/16 in. or 1.*

## 4.5 Hydraulic Fitting Torque (Triple-LOK™) for Fixed Displacement Hydraulic Power Units

Stainless Steel Triple-LOK (37° JIC or commonly referred to as flared) fittings are mainly used on Hanna's Fixed Displacement Hydraulic Power Units. The fittings are completely assembled and ready for immediate use. Table 4-1 gives the torque values for Triple-LOK (JIC) fittings.

**Table 4-1 Triple-Lok (JIC) Assembly Torques and FFWR**

SAE Dash Size	Thread Size	Assembly Torque <sup>1</sup> (+10% -0)		Tube Connection FFWR <sup>2</sup>	Swivel Nut or Hose Connection FFWR <sup>2</sup>
		in. lb.	ft. lb.		
-2	5/16-24	35	2	--	--
-3	3/8-24	65	5	--	--
-4	7/16-20	130	11	2	2
-5	½-20	165	14	2	2
-6	9/16-18	235	20	1-1/2	1-1/4
-8	¾-16	525	43	1-1/2	1
-10	7/8-14	650	55	1-1/2	1
-12	1-1/16-12	950	80	1-1/4	1
-14	1-3/16-12	1200	100	1	1
-16	1-5/16-12	1400	115	1	1
-20	1-5/8-12	1900	160	1	1
-24	1-7/8-12	2250	185	1	1
-32	2-1/2-12	3000	250	1	1
-40	3-12	--	--	1	1

1. Torque values are for unlubricated carbon steel components and properly lubricated stainless steel components. For brass fittings, use approximately 65% of the torque values shown, unlubricated. For stainless steel, a lubricant such as Permatex Anti-Seize is recommended to prevent galling.
2. The "Flats from Wrench Resistance" or "Flats" method is recommended for steel, stainless steel, and brass components.



## 4.6 Hanna Hydraulic Tubing Color Code

Hanna uses colored tape on all hydraulic tubing at the factory. Figure 4-2 shows the color code on all Hanna hydraulic operated equipment.



# HANNA

<b>HYDRAULIC TUBING COLOR CODE</b>		
<b>EQUIPMENT</b>	<b>COLOR CODE</b>	
Pressure Line	1 Stripe	
Return Line	2 Stripes	
Wraparound 98-C or Flex	Black	
Tire Washer	Brown	
HCRP	White	
Auto Prep	Purple	
SHWW or ASWW	Green	
Mitter Any Model	Blue	
Top Washer or Any Mitter	Yellow	
<b>SPARE COLORS</b>		
Also Code the Following:		
Superwave, High PSI Arch	Red	
and Any 2nd Brush in Syst.	Orange	
<b>Multi Equipment Combo's</b>		
1st Mitter in System	Blue	
2nd Mitter	Yellow	
3rd Mitter	Red	
1st ASWW in System	Green	
2nd ASWW	Orange	
3rd ASWW	Red	

Figure 4- 2 Hanna Hydraulic Tubing Color Code

This page intentionally left blank.

## 5.0 Parts and Maintenance

### 5.1 General Maintenance

The XT DTM requires periodic inspection and maintenance. However, there are only a few items that should be inspected on a regular basis. For the first month of operation check, on a weekly basis, hardware for tightness on crank arms, tie rods, bearings, vertical-mount legs, shear bolts, stop collars, and hydraulic-motor mounts.

#### 5.1.1 Daily Maintenance

- ✓ Check the curtains for tears in the cloth (if any curtain is torn correct this by cutting the torn portion out in a “half moon” shape cut)
- ✓ Check the unit for proper operation prior to washing the first vehicle each day
- ✓ Check spray nozzles for proper delivery of water on the curtains
- ✓ Check hydraulic lines for leaks

#### 5.1.2 Weekly Maintenance

- ✓ Check water solenoid valve for positive on/off operation
- ✓ Check alignment of curtain baskets in relation to each other
- ✓ Check tie rod alignment
- ✓ Check tie-rod bearings for proper vertical alignment

#### 5.1.3 Monthly Maintenance

- ✓ Check hydraulic lines and water hoses for wear or rub

- ✓ Check frame, legs, and cross beams for cleanliness
- ✓ Check frame, legs, and cross beams for cracks and loose bolts
- ✓ Check spray nozzles for wear
- ✓ Check all bearings for wear

## 5.2 Lubrication of Bearings

Any lubrication program is only as good as the lubricants used. We suggest you review this information and stock up on the best lubricants available.

Table 5-1 shows you the amount of grease to use depending on your operating conditions. It is recommended that once you decide on a type of lithium grease that you stick to the same type of lithium grease when you lubricate your bearings.

Weekly: Lubricate bearings using high-quality multi-purpose lithium grease.

**Table 5-1 Grease Application Conditions**

Operating Conditions	Grease Supply (gf)
Normal	0.6
Minor Dust	1.2
Considerable Dust	1.8

gf = grams force

### 5.3 Bearing Replacement

The Hanna XT Diagonal Touch Mitter has two basket bearings (Figure 5-1). Hanna recommends that you replace both bearings at the same time. To remove and replace a bearing:

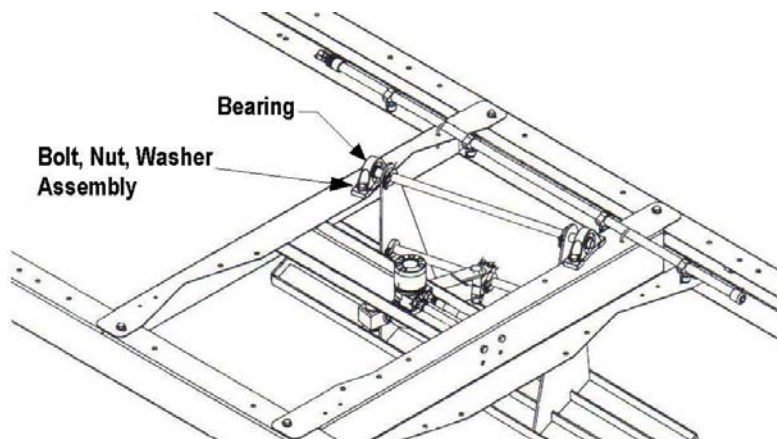

**Figure 5-1 Top View of Basket Bearings**

1. On the bearing, push up the castle washer tab (Figure 5-2) from the slot in the spanner bearing.

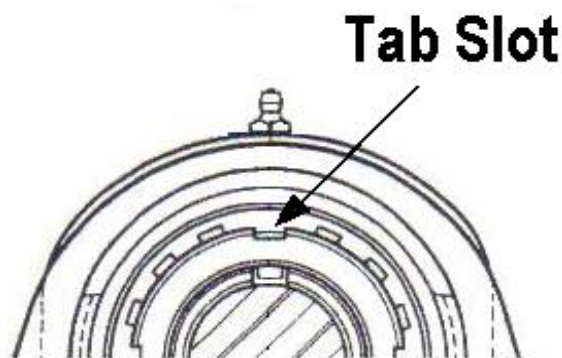

**Figure 5-2 Bearing Tab Slot Location**

- Remove the nuts, washers, and bolts that fasten the bearing housing to the structure (Figure 5-3).

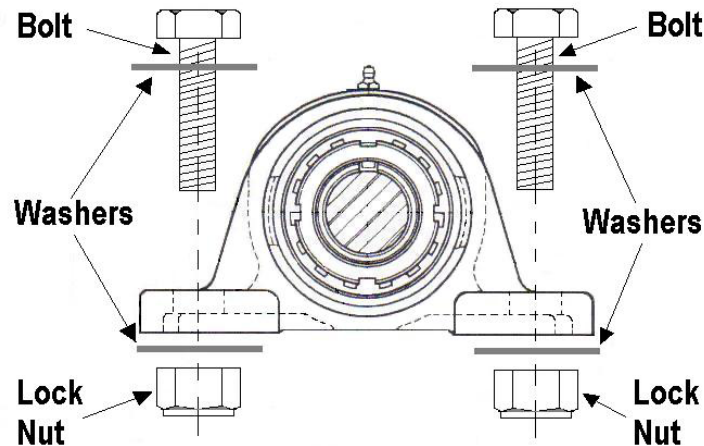

Figure 5-3 Bearing Housing with Nuts, Washers, and Bolts

- Remove the spanner nut and castle washer (Figure 5-4).

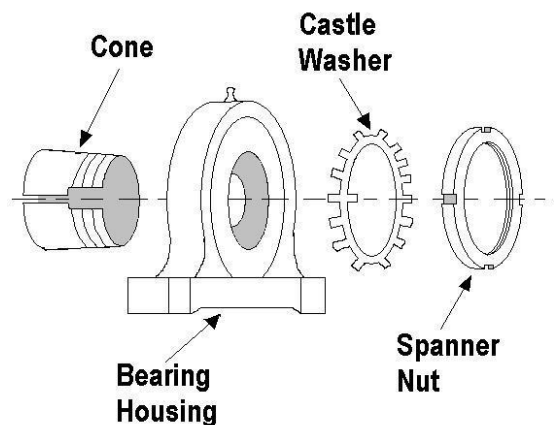

Figure 5-4 Bearing Assembly

- At this point you will need to loosen the cone from the shaft. Using a dead blow hammer, hit the back side of the bearing housing to separate the cone from the shaft. The cone and bearing are taper fit.
- Using a suitable and safe lift mechanism (500 lb capacity), lift the carriage assembly ap-

proximately ¼ in. to ½ in. or just enough to be able to remove the old bearing.

6. Remove the bearing from the shaft.
7. Install the new bearing, with cone insert, onto the shaft (Figure 5-5).

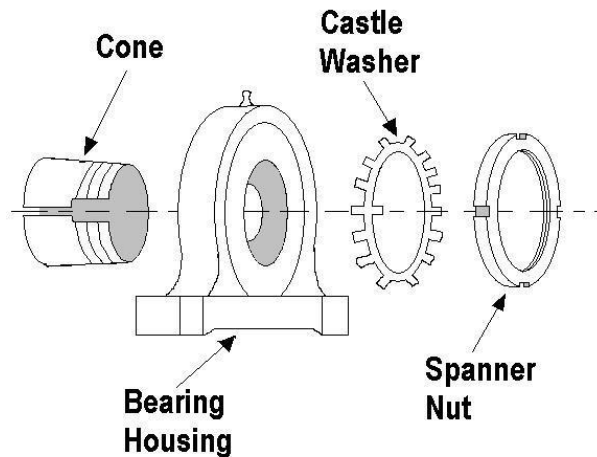

Figure 5-5 Bearing Assembly

8. Line up the new bearing mounting holes with the holes in the structure.
9. Insert the nuts, washers, and bolts (Figure 5-6) to attach the bearing to the structure and tighten. Dip your bolt in a heavy type of lubricating oil such as Trim™ Tap Heavy to keep the bolt and nut from seizing.

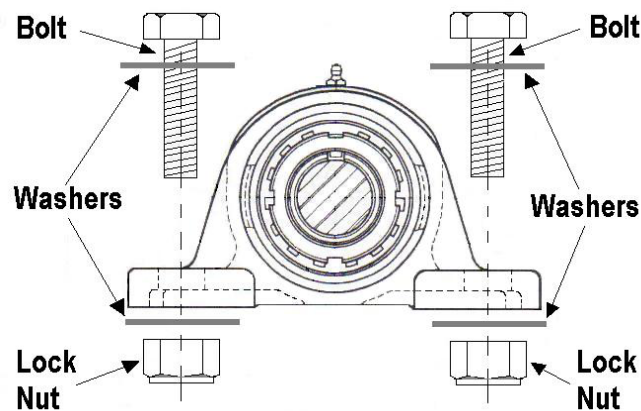
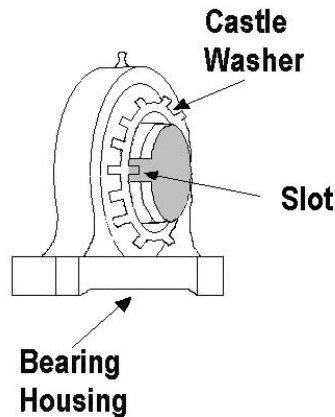

Figure 5-6 Bearing Housing with Nuts, Washers, and Bolts

10. Install the new castle washer onto the assembly inserting the internal tab into the cone slot. Make sure the castle washer tabs are pointing out, away from the bearing. This is very important because if the tabs are pointing toward the bearing it will be difficult to bend the tab into the spanner nut slot.



**Figure 5-7 Bearing with Castle Washer and Cone**

11. Install the new spanner nut onto the assembly with the raised or convex side up against the castle washer facing the bearing (Figure 5-8). Tighten the spanner nut hand tight and then tighten  $\frac{1}{2}$  turn with a spanner wrench. Do not over tighten as this will damage the cone and/or the shaft.

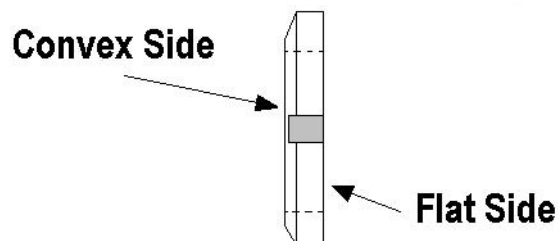

**Figure 5-8 Bearing Spanner Nut**



12. Bend the castle washer tab into the slot on the spanner nut (Figure 5-9). This will lock the nut in place.

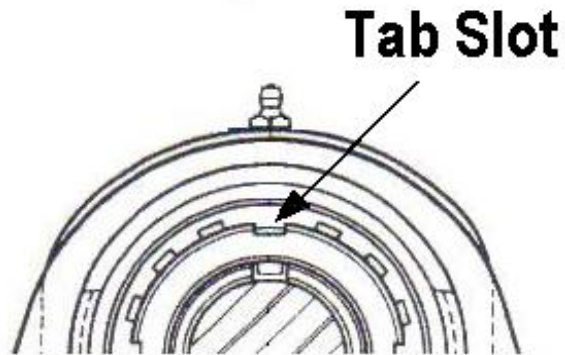

**Figure 5-9 Castle Washer Tab Slot**

13. Lubricate the bearing with high-quality lithium grease.
14. Repeat these steps to replace the bearing on the other side.

## 5.4 Spare Parts List

Table 5-2 shows the recommended spare parts to be kept on hand by the Distributor and Owner/Operator.

**Table 5-2 Recommended Spare Parts List**

<b>Recommended Parts</b>	<b>Part Number</b>	<b>Distributor Carries Part In Stock</b>	<b>Owner/Operator<sup>1</sup> (Distributor Support) Carries Part In Stock</b>	<b>Owner/Operator<sup>2</sup> (No Distributor Support) Carries Part In Stock</b>
Clip, Mitter	805469	YES	NO	YES
Curtain, 6 in.x102 in.	759803	YES	NO	NO
Motor, Hydraulic For Pressure Comp. Units	366906	YES	NO	YES
Motor, Hydraulic For Fixed Displacement. Units	366067	YES	NO	YES
Bearing	367457	YES	NO	YES
Jet, Nylon	363265	YES	NO	YES

1. Recommends what spare parts should be kept on hand by the Car Wash Owner/Operator if there is close support from the distributor and parts are quickly obtainable.
2. Recommends what spare parts should be kept on hand by the Car Wash Owner/Operator if there is NOT close support from the distributor and parts are NOT quickly obtainable.

## 5.5 Recommended Tool Kit

Table 5-3 shows the recommended tools for installation and maintenance of the XT DTM System.

**Table 5-3 Recommended Installation Tools**

13/16 in.	Open-End Box Wrench
7/8 in.	Open-End Box Wrench
¾ in.	Open-End Box Wrench
7/16 in.	Open-End Box Wrench
½ in.	Open-End Box Wrench
9/16 in.	Open-End Box Wrench
1/8 in.	Ball-End Hex Bit T-Wrench
5/32 in.	Ball-End Hex Bit T-Wrench
3/16 in.	Ball-End Hex Bit T-Wrench
¼ in.	Ball-End Hex Bit T-Wrench
12 in.	Adjustable Wrench
10 oz	“Dead Blow” Plastic Mallet
	Spanner Wrench

## 5.6 Replacement Parts

See Assembly drawings in Appendix A for replacement parts.

This page intentionally left blank.

## 6.0 Troubleshooting

This chapter helps you solve common mitter problems. If you are still unable to find a solution after reading through this section, please call your distributor for technical assistance.

### 6.1 Mitter Problems

<u>Problem</u>	<u>Possible Solutions</u>
<ul style="list-style-type: none"> <li>▪ BINDING OR JUMPING</li> </ul>	<ul style="list-style-type: none"> <li>▪ Check bearings for wear</li> <li>▪ Check shaft for alignment</li> <li>▪ Check crank arms for wear</li> <li>▪ Check primary drive motor</li> </ul>
<ul style="list-style-type: none"> <li>▪ UNIT WILL NOT – STOP/START</li> </ul>	<ul style="list-style-type: none"> <li>▪ Check hydraulic solenoid valve</li> <li>▪ Check computer functions</li> <li>▪ Check hydraulic motor</li> </ul>
<ul style="list-style-type: none"> <li>▪ WATER WILL NOT SHUT-OFF</li> </ul>	<ul style="list-style-type: none"> <li>▪ Check water solenoid valve for sticking</li> <li>▪ Check for contamination in solenoid valve</li> </ul>
<ul style="list-style-type: none"> <li>▪ SQUEAKING</li> </ul>	<ul style="list-style-type: none"> <li>▪ Apply grease to bearings</li> <li>▪ Lubricate crank arm bearings</li> </ul>

## 6.2 Hydraulic Fitting Problems

<ul style="list-style-type: none"> <li>▪ TUBE NUT CONTINUES TO BACK OFF OR LOOSEN</li> </ul>	<ul style="list-style-type: none"> <li>▪ Excessive vibration can cause the 37° tube flare nut to back off from the fitting body. Consider better tube line routing and clamping to protect the fitting/tube union or control the system vibration.</li> </ul>
<ul style="list-style-type: none"> <li>▪ FLARE ON TUBE FITTING IS COLLAPSED</li> </ul>	<ul style="list-style-type: none"> <li>▪ 37° fittings are susceptible to over torque. Once the tube fitting has been over torqued the sealing capability is nearly gone. Additional tightening on the tube/hose joint will only cause additional leakage. Replace fitting and retighten with appropriate torque or FFWR method.</li> </ul>
<ul style="list-style-type: none"> <li>▪ DAMAGED FITTING</li> </ul>	<ul style="list-style-type: none"> <li>▪ Due to repeated use, abuse, handling, etc., the 37° flare fittings are susceptible to damage on the flare end of the fitting. These problems can often be avoided by proper handling and storage, including keeping plastic fitting caps and plugs on until fitting is used.</li> </ul>
<ul style="list-style-type: none"> <li>▪ TUBE IS OVER FLARED OR UNDER FLARED</li> </ul>	<ul style="list-style-type: none"> <li>▪ If tube is over flared the tube nut will not be able to engage fitting body or not be able to swivel freely. If tube is under flared, the possibility for tube blow off is greatly increased and the sealing area is greatly reduced. Re-flare to appropriate flare O.D. specifications as outlined in this catalog.</li> </ul>
<ul style="list-style-type: none"> <li>▪ POCK MARKS ON FLARE I.D.</li> </ul>	<ul style="list-style-type: none"> <li>▪ Tube end not deburred or cleaned properly before flaring.</li> </ul>

<ul style="list-style-type: none"> <li>▪ LEAKAGE – TUBE MISALIGNMENT OR IMPROPER FIT</li> </ul>	<ul style="list-style-type: none"> <li>▪ Align the flared tube end and the connecting tube fitting before tightening the tube nut. Ensure that the tubing is bent to the appropriate bend angles. Do not “force” the tube assembly into position. Use two wrenches during assembly.</li> </ul>
<ul style="list-style-type: none"> <li>▪ LEAKAGE – IMPROPER TIGHTENING</li> </ul>	<ul style="list-style-type: none"> <li>▪ Check the joint for appropriate tightness. Re-torque or use the FFWR method of assembly to ensure appropriate joint makeup. If leakage persists, it could be a problem listed below.</li> </ul>
<ul style="list-style-type: none"> <li>▪ LEAKAGE – TUBE CRACKED ALONG FLARE</li> </ul>	<ul style="list-style-type: none"> <li>▪ Poor quality tube, work-hardened tube, or faulty tube preparation can cause the tube to crack. Re-flare while addressing the aforementioned issues. Do not use a tube cutter with steel and stainless steel tube, as tube cutters tend to “work harden” the tube before flaring.</li> </ul>
<ul style="list-style-type: none"> <li>▪ LEAKAGE – TUBE SEALING SURFACE HAS IMPERFECTION CAUSING LEAKAGE BETWEEN TUBE FITTING AND TUBE FLARE</li> </ul>	<ul style="list-style-type: none"> <li>▪ Low quality welding tube often will leave a weld bead causing a leak path between the fitting and tube flare. Use a high-quality seamless or welded and redrawn type of tube. Problems with the flaring tooling can also cause a surface imperfection on the sealing surface of the tube flare as well. Flare cones/burnishing heads, when damaged can cause these imperfections in the mating tube flare. Re-flare while addressing the aforementioned problem areas.</li> </ul>

This page intentionally left blank.



## **Appendix A**

### **Table of Drawings**

#### **System Configuration**

**425924, XT DTM Assembly, 90 in. Clearance, Fixed Displacement, 1 of 3**

**425924, XT DTM Assembly, 90 in. Clearance, Fixed Displacement, 2 of 3**

**425924, XT DTM Assembly, 90 in. Clearance, Fixed Displacement, 3 of 3**

**425925, XT DTM Assembly, 96 in. Clearance, Pressure Compensated, 1 of 3**

**425925, XT DTM Assembly, 96 in. Clearance, Pressure Compensated, 2 of 3**

**425925, XT DTM Assembly, 96 in. Clearance, Pressure Compensated, 3 of 3**

#### **Freestanding Configuration**

**426077, XT DTM Assembly, 90 in. Clearance, Pressure Compensated, 1 of 3**

**426077, XT DTM Assembly, 90 in. Clearance, Pressure Compensated, 2 of 3**

**426077, XT DTM Assembly, 90 in. Clearance, Pressure Compensated, 3 of 3**

**426080, XT DTM Assembly, 96 in. Clearance, Fixed Displacement, 1 of 3**

**426080, XT DTM Assembly, 96 in. Clearance, Fixed Displacement, 2 of 3**

**426080, XT DTM Assembly, 96 in. Clearance, Fixed Displacement, 3 of 3**

#### **Hydraulic System**

**812820, XT DTM Hydraulic Assembly, Pressure Compensated**

**812980, XT DTM Hydraulic Assembly, Fixed Displacement**

This page intentionally left blank.

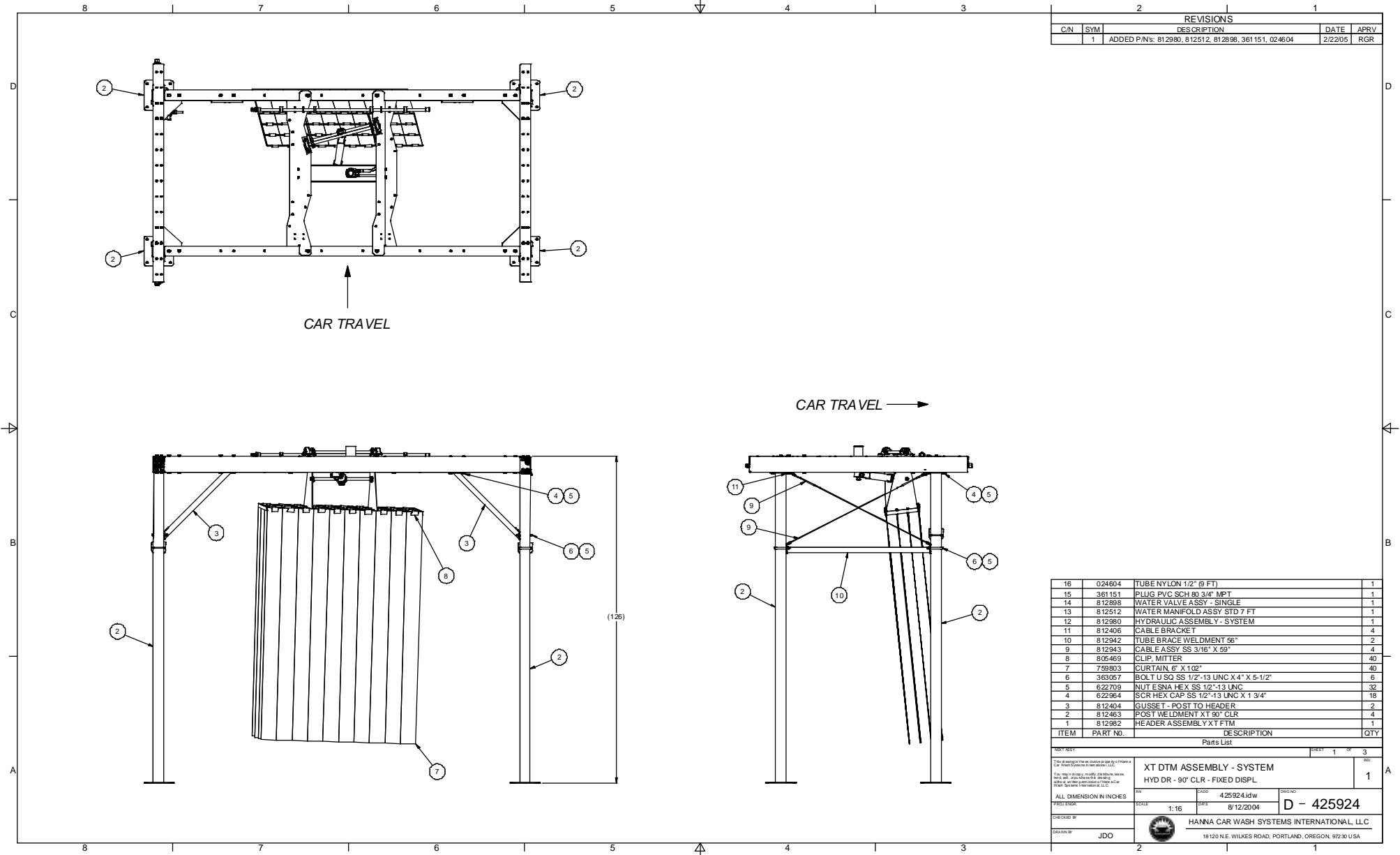

REVISIONS				
C/N	SYM	DESCRIPTION	DATE	APRV
1		ADDED P/Ns: 812980, 812512, 812898, 361151, 024604	2/22/05	RGR

ITEM	PART NO.	DESCRIPTION	QTY
16	024604	TUBE NYLON 1/2" (6 FT)	1
15	361151	PLUG PVC SCH 80 3/4" MPT	1
14	812898	WATER VALVE ASSY - SINGLE	1
13	812512	WATER MANIFOLD ASSY STD 7 FT	1
12	812980	HYDRAULIC ASSEMBLY - SYSTEM	1
11	812406	CABLE BRACKET	4
10	812942	TUBE BRACE WELDMENT 56"	2
9	812943	CABLE ASSY SS 3/16" X 59"	4
8	805469	CLIP, MITTER	40
7	759803	CURTAIN, 6" X 102"	40
6	363057	BOLT U SQ SS 1/2"-13 UNC X 4" X 5-1/2"	6
5	622709	NUT ESNA HEX SS 1/2"-13 UNC	32
4	622864	SCR HEX CAP SS 1/2"-13 UNC X 1 3/4"	16
3	812404	GUSSET - POST TO HEADER	2
2	812463	POST WELDMENT XT 90° CLR	4
1	812982	HEADER ASSEMBLY XT FTM	1

XT DTM ASSEMBLY - SYSTEM  
 HYD DR - 90° CLR - FIXED DISPL

DWG NO: 425924.dwg  
 DATE: 8/12/2004  
 SCALE: 1:16

**D - 425924**

HANNA CAR WASH SYSTEMS INTERNATIONAL, LLC  
 18120 N.E. WILKES ROAD, PORTLAND, OREGON, 97230 U.S.A.

DRAWN BY: JDO

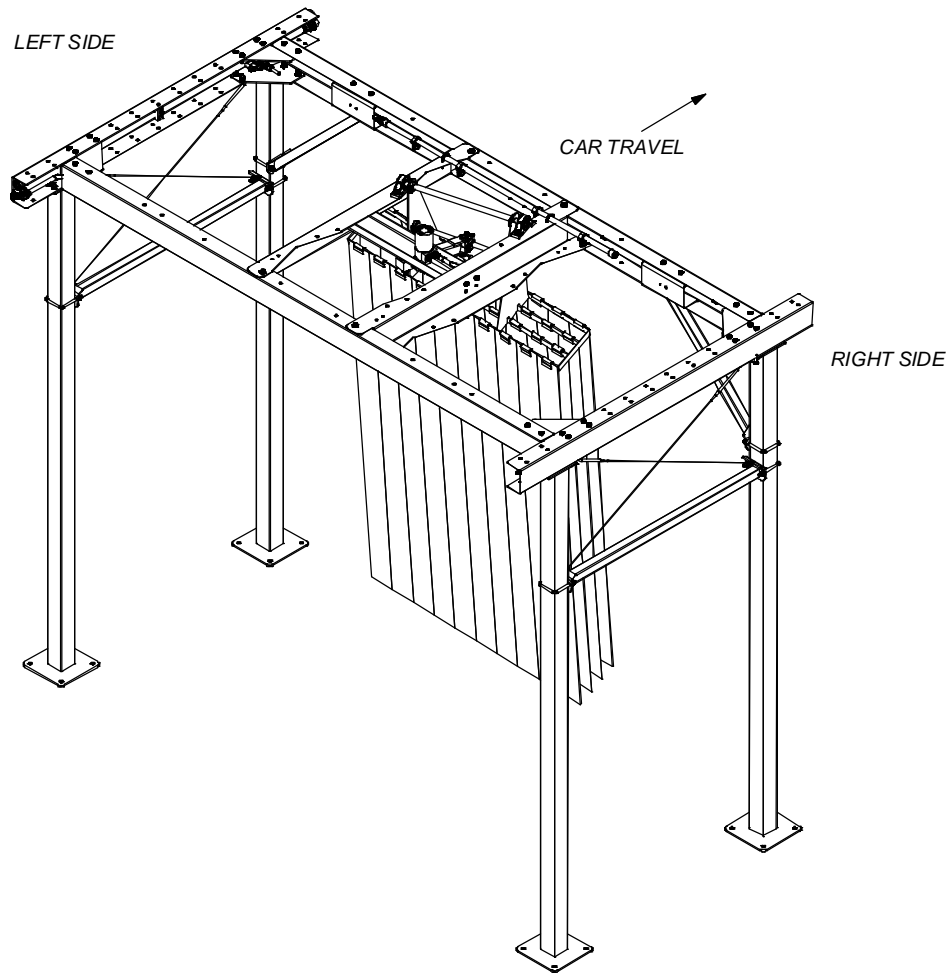

<small>THIS DRAWING IS THE PROPERTY OF HANNA CAR WASH SYSTEMS INTERNATIONAL, LLC. IT IS TO BE USED ONLY FOR THE PROJECT AND SITE SPECIFICALLY IDENTIFIED HEREIN. ANY REUSE OR MODIFICATION OF THIS DRAWING WITHOUT THE WRITTEN PERMISSION OF HANNA CAR WASH SYSTEMS INTERNATIONAL, LLC IS STRICTLY PROHIBITED.</small>		<b>XT DTM ASSEMBLY - SYSTEM</b> <b>HYD DR - 90° CLR - FIXED DISPL</b>		SHEET 2 OF 3 1	
ALL DIMENSION IN INCHES FIRST EDGE	DWG NO: 425924.dwg SCALE: 1:12 DATE: 8/12/2004	DWG NO: D - 425924	HANNA CAR WASH SYSTEMS INTERNATIONAL, LLC 18120 N.E. WILKES ROAD, PORTLAND, OREGON, 97230 U.S.A.		
CHECKED BY: JDO	DRAWN BY: JDO				

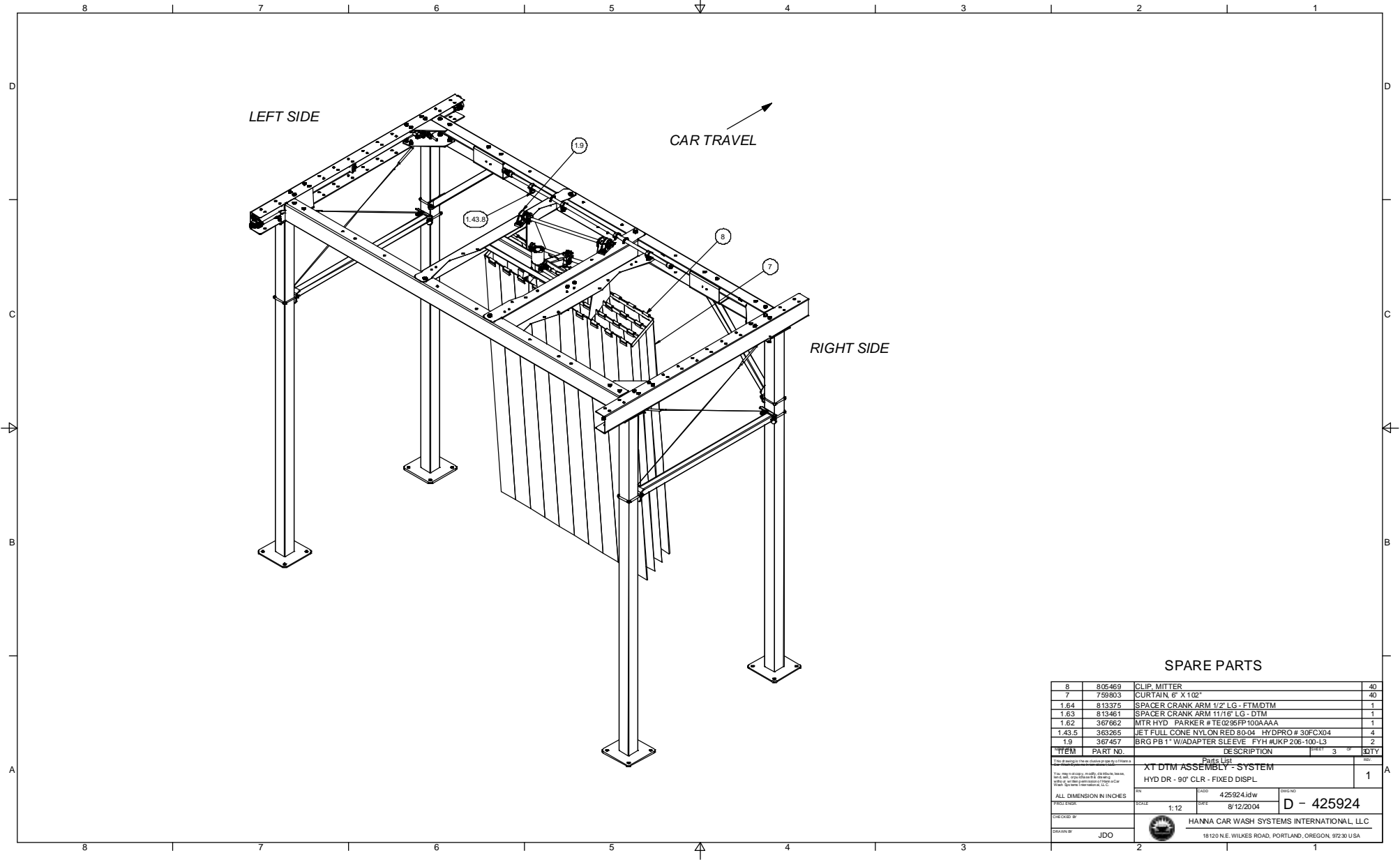

**SPARE PARTS**

8	805469	CLIP, MITTER	40
7	759803	CURTAIN 6' X 102"	40
1.64	813375	SPACER CRANK ARM 1/2' LG - FTM DTM	1
1.63	813461	SPACER CRANK ARM 11/16' LG - DTM	1
1.62	367662	MTR HYD PARKER # TE0295FP100AAAA	1
1.43.5	363265	JET FULL CONE NYLON RED 80-04 HYDPRO# 30FCX04	4
1.9	367457	BRG PB 1" W/ADAPTER SLEEVE FYH #UKP 206-100-L3	2

ITEM	PART NO.	DESCRIPTION	QTY
		Parts List	3
		XT DTM ASSEMBLY - SYSTEM	1
		HYD DR - 90° CLR - FIXED DISPL	1

ALL DIMENSION IN INCHES  
 SCALE: 1:12  
 DATE: 8/12/2004  
 D - 425924  
 HANNA CAR WASH SYSTEMS INTERNATIONAL, LLC  
 18120 N.E. WILKES ROAD, PORTLAND, OREGON, 97230 U.S.A.

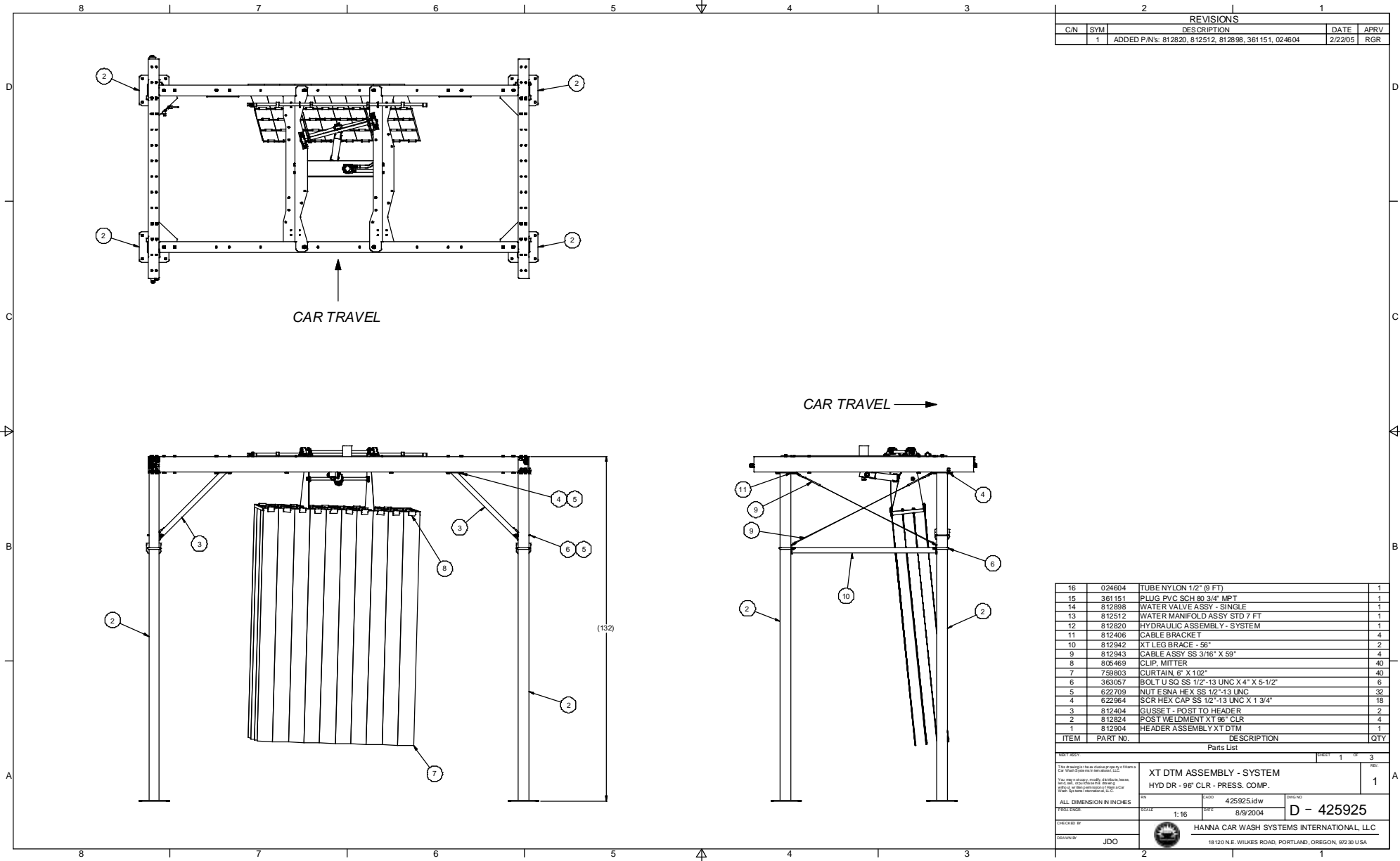

REVISIONS				
C/N	SYM	DESCRIPTION	DATE	APRV
1		ADDED P/Ns: 812820, 812512, 812898, 361151, 024604	2/22/05	RGR

ITEM	PART NO.	DESCRIPTION	QTY
16	024604	TUBE NYLON 1/2" (6 FT)	1
15	361151	PLUG PVC SCH 80 3/4" MPT	1
14	812898	WATER VALVE ASSY - SINGLE	1
13	812512	WATER MANIFOLD ASSY STD 7 FT	1
12	812820	HYDRAULIC ASSEMBLY - SYSTEM	1
11	812406	CABLE BRACKET	4
10	812842	XT LEG BRACE - 56"	2
9	812943	CABLE ASSY SS 3/16" X 59"	4
8	805469	CLIP, MITTER	40
7	759803	CURTAIN, 6" X 102"	40
6	363057	BOLT U SQ SS 1/2"-13 UNC X 4" X 5-1/2"	6
5	622709	NUT ESNA HEX SS 1/2"-13 UNC	32
4	622864	SCR HEX CAP SS 1/2"-13 UNC X 1 3/4"	18
3	812404	GUSSET - POST TO HEADER	2
2	812824	POST WELDMNT XT 96" CLR	4
1	812904	HEADER ASSEMBLY XT DTM	1

Parts List

1 of 3

XT DTM ASSEMBLY - SYSTEM  
HYD DR - 96" CLR - PRESS. COMP.

REV 425925.dwg DWG NO  
DATE 8/9/2004  
D - 425925

HANNA CAR WASH SYSTEMS INTERNATIONAL, LLC  
18120 N.E. WILKES ROAD, PORTLAND, OREGON, 97230 U.S.A.

DESIGNED BY: JDO  
DRAWN BY: JDO

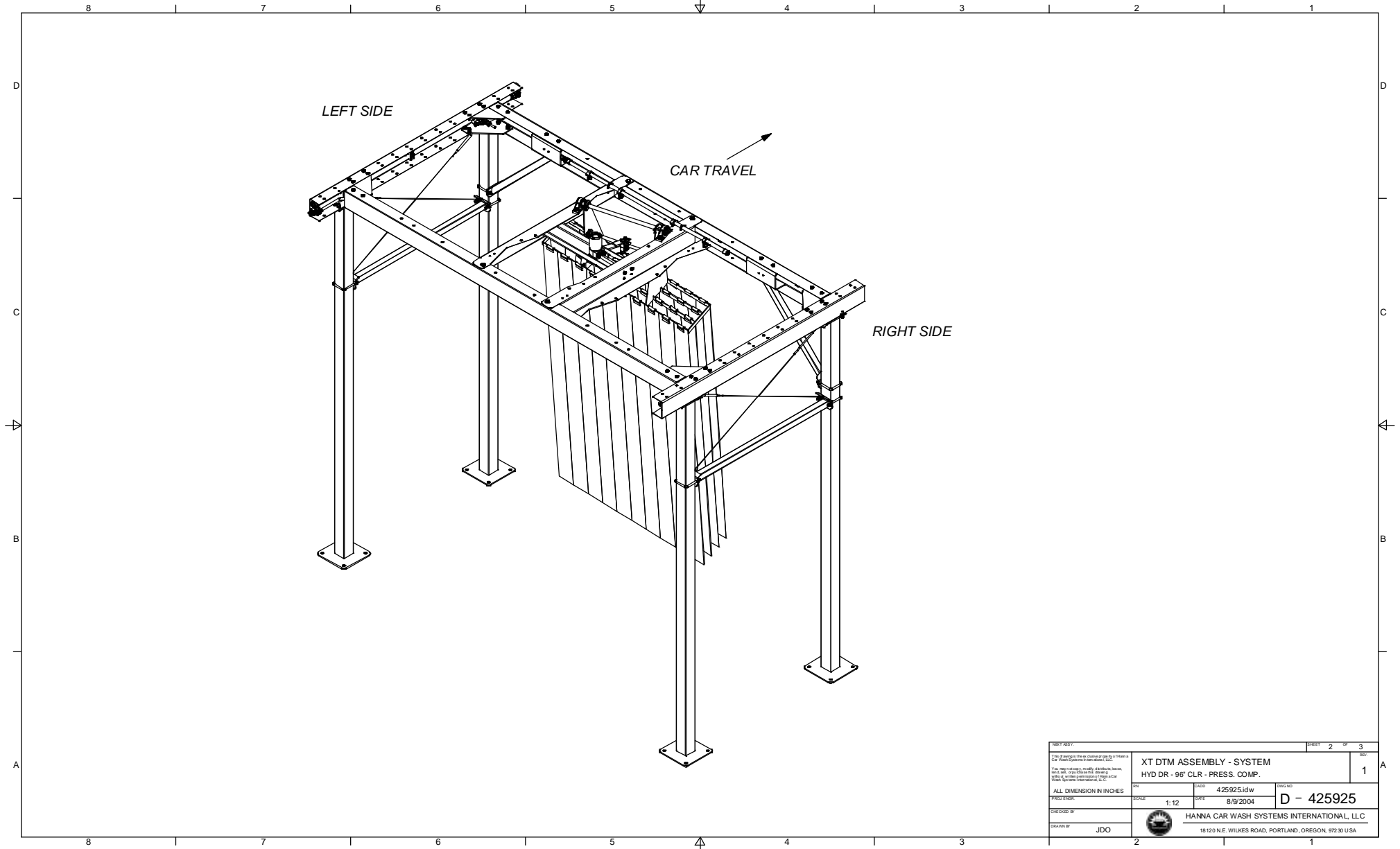

<small>THIS DRAWING IS THE PROPERTY OF HANNA CAR WASH SYSTEMS INTERNATIONAL, LLC. IT IS TO BE USED ONLY FOR THE PROJECT AND SITE SPECIFICALLY IDENTIFIED HEREIN. ANY REUSE OR MODIFICATION OF THIS DRAWING WITHOUT THE WRITTEN PERMISSION OF HANNA CAR WASH SYSTEMS INTERNATIONAL, LLC IS STRICTLY PROHIBITED.</small>		<b>XT DTM ASSEMBLY - SYSTEM</b> <b>HYD DR - 96" CLR - PRESS. COMP.</b>		SHEET 2 OF 3 1	
ALL DIMENSION IN INCHES FIRST EDGE	NO. 425925.dwg DATE 8/9/2004	DWG NO. D - 425925			
CHECKED BY: JDO	HANNA CAR WASH SYSTEMS INTERNATIONAL, LLC 18120 N.E. WILKES ROAD, PORTLAND, OREGON, 97230 USA				

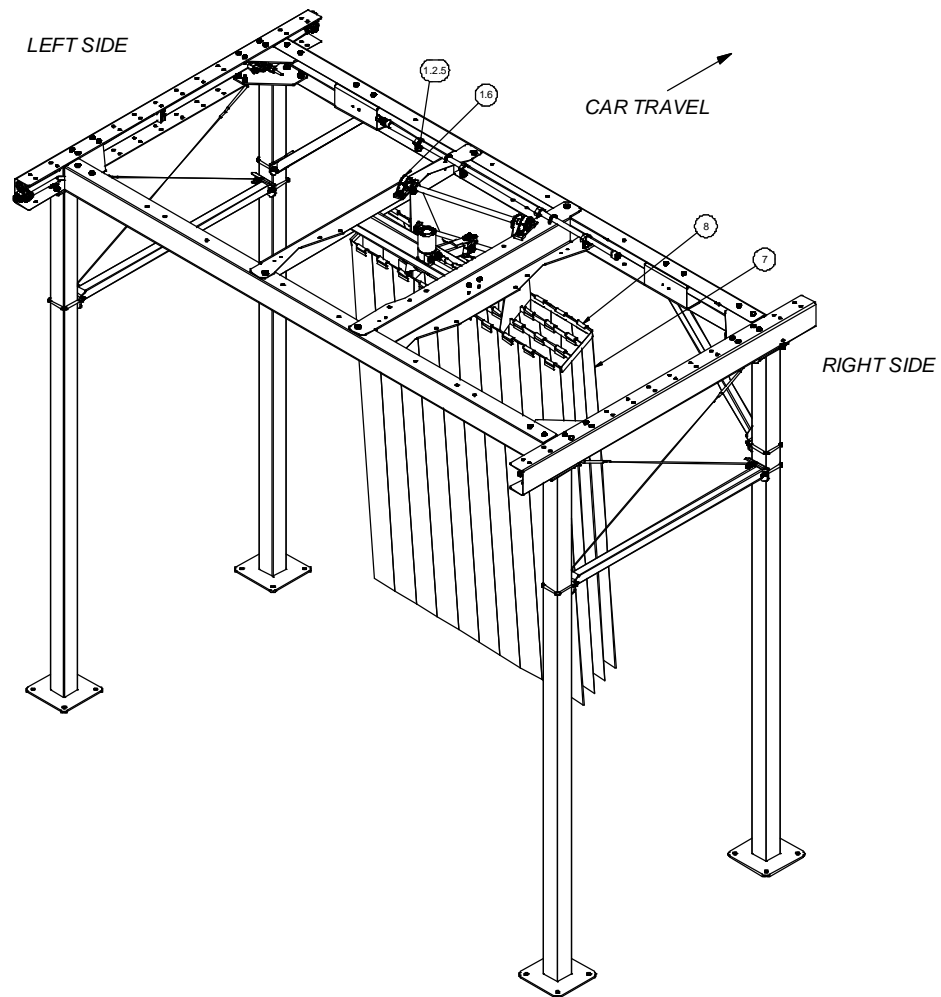

**SPARE PARTS**

8	805469	CLIP, MITTER	40
7	759803	CURTAIN 6' X 102"	40
1.44	813375	SPACER CRANK ARM 1/2' LG - FTM/DTM	1
1.43	813461	SPACER CRANK ARM 11/16' LG - DTM	1
1.42	366907	MTR HYD PARKER # TE0295FS100AAAA	1
1.6	367457	BRG PB 1" W/ADAPTER SLEEVE FYH #JKP 206-100-L3	2
1.2.5	363265	JET FULL CONE NYLON RED 80-04 HYDPRO # 30FCX04	4
<b>ITEM</b>	<b>PART NO.</b>	<b>DESCRIPTION</b>	<b>QTY</b>
<b>Parts List</b> <b>XT DTM ASSEMBLY - SYSTEM</b> <b>HYD DR - 96" CLR - PRESS. COMP.</b>			<b>1</b>
<small>THIS DRAWING IS THE PROPERTY OF HANNA CAR WASH SYSTEMS INTERNATIONAL, LLC. IT IS TO BE USED ONLY FOR THE PROJECT AND SITE SPECIFICALLY IDENTIFIED HEREON. IT IS NOT TO BE REPRODUCED, COPIED, OR TRANSMITTED IN ANY FORM OR BY ANY MEANS, ELECTRONIC OR MECHANICAL, WITHOUT THE WRITTEN PERMISSION OF HANNA CAR WASH SYSTEMS INTERNATIONAL, LLC.</small>		<small>REV</small> <small>DATE</small> 4/25/05 JdW <small>ENG NO</small>	<small>SCALE</small> 1:12
<small>ALL DIMENSION IN INCHES</small>		<small>DATE</small> 8/9/2004 <b>D - 425925</b>	
<small>CHECKED BY</small> <small>DRAWN BY</small> JDO		<b>HANNA CAR WASH SYSTEMS INTERNATIONAL, LLC</b> 18120 N.E. WILKES ROAD, PORTLAND, OREGON, 97230 USA	



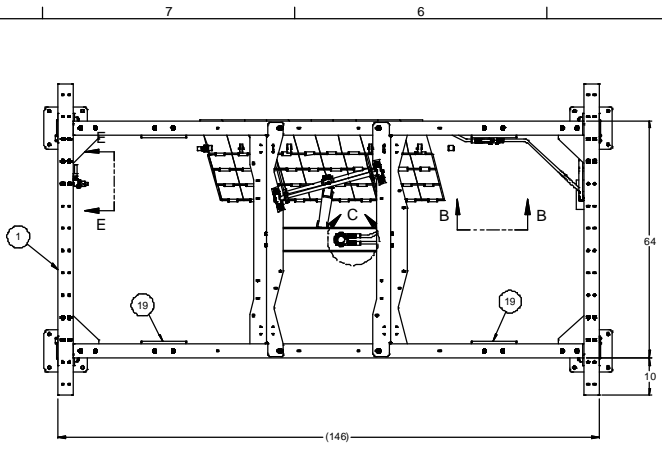

CAR TRAVEL

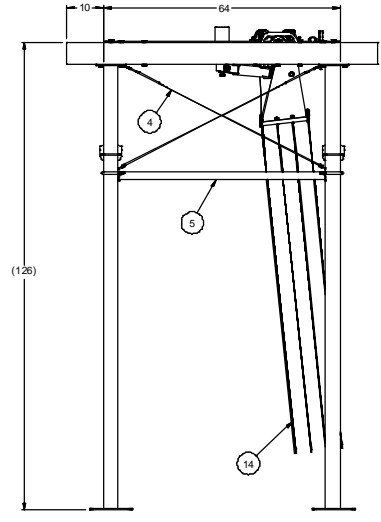
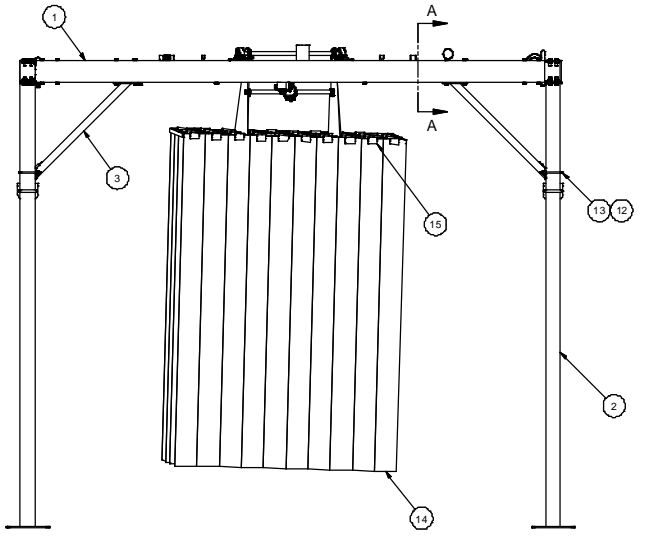
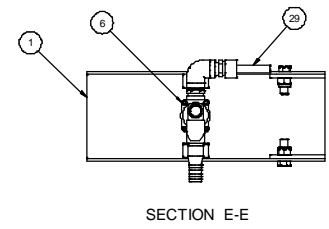
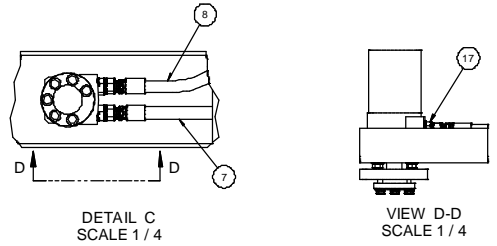
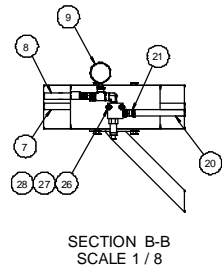
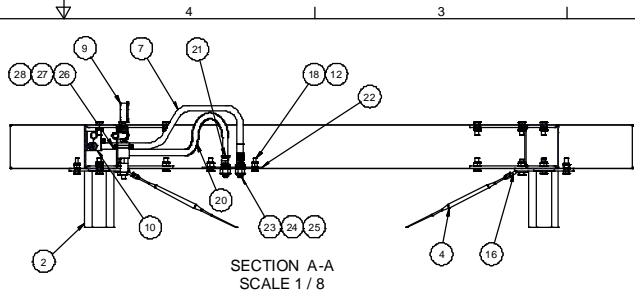

29	024604	TUBE NYLON 1/2" (8 FT)	1
28	622708	NUT ESNA HEX SS 1/4" 20 UNC	2
27	623042	WSHR FLAT SS 1/4"	4
26	366148	SCR HEX CAP SS 1/4" 20 UNC X 1-1/2"	2
25	622729	NUT HEX JAM SS 3/4" 10 UNC	2
24	622987	WSHR INT STAR SS 3/4"	2
23	363482	FTG BKHD UNION 1/2" MJIC X 1/2" MJIC	2
22	803868	BULKHEAD MFG PLATE	1
21	367608	FTG HYD STR BR NI PL 1/2" HOSE BARB X 1/2" FJIC	2
20	367611	HOSE HYD 1/2" PUSH-LOK BLUE (3 FT)	1
19	812620	GUSSET STIFFENER	2
18	622934	SCR HEX CAP SS 1/2" 13 UNC X 1 1/2"	14
17	367486	FTG HYD STR STL NI PL 7/8"-14 O-RING X 1/2" MJIC	2
16	812406	CABLE BRACKET	4
15	805469	CLIP MITTER	40
14	759803	CURTAIN 6" X 102"	40
13	363057	BOLT U SQ SS 1/2" 13 UNC X 4" X 5-1/2"	8
12	622709	NUT ESNA HEX SS 1/2" 13 UNC	50
11	622964	SCR HEX CAP SS 1/2" 13 UNC X 1 3/4"	20
10	367570	CLAMP TWIN SS 1/2" HOSE	4
9	810573	PRESSURE CONTROL VALVE ASSY	1
8	813319	HOSE ASSY 1/2" X 60" STR FJIC X STR FJIC	1
7	813318	HOSE ASSY 1/2" X 102" STR FJIC X STR FJIC	1
6	813320	WATER VALVE ASSY	1
5	812942	XT LEG BRACE - 56"	2
4	812943	CABLE ASSY SS 3/16" X 59"	4
3	812404	GUSSET - POST TO HEADER	4
2	812463	POST WELDMENT XT 90" CLR	4
1	812904	HEADER ASSEMBLY XT DTM	1
ITEM	PART NO.	DESCRIPTION	QTY

Parts List

1 of 3

XT DTM ASSEMBLY - FS  
HYD DR - 90" CLR - PRESS. COMP.

NO. 426077.dwg  
DATE 2/9/2005  
SCALE 1:12  
DWG D - 426077

HANNA CAR WASH SYSTEMS INTERNATIONAL, LLC  
18120 N.E. WILKES ROAD, PORTLAND, OREGON, 97230 USA

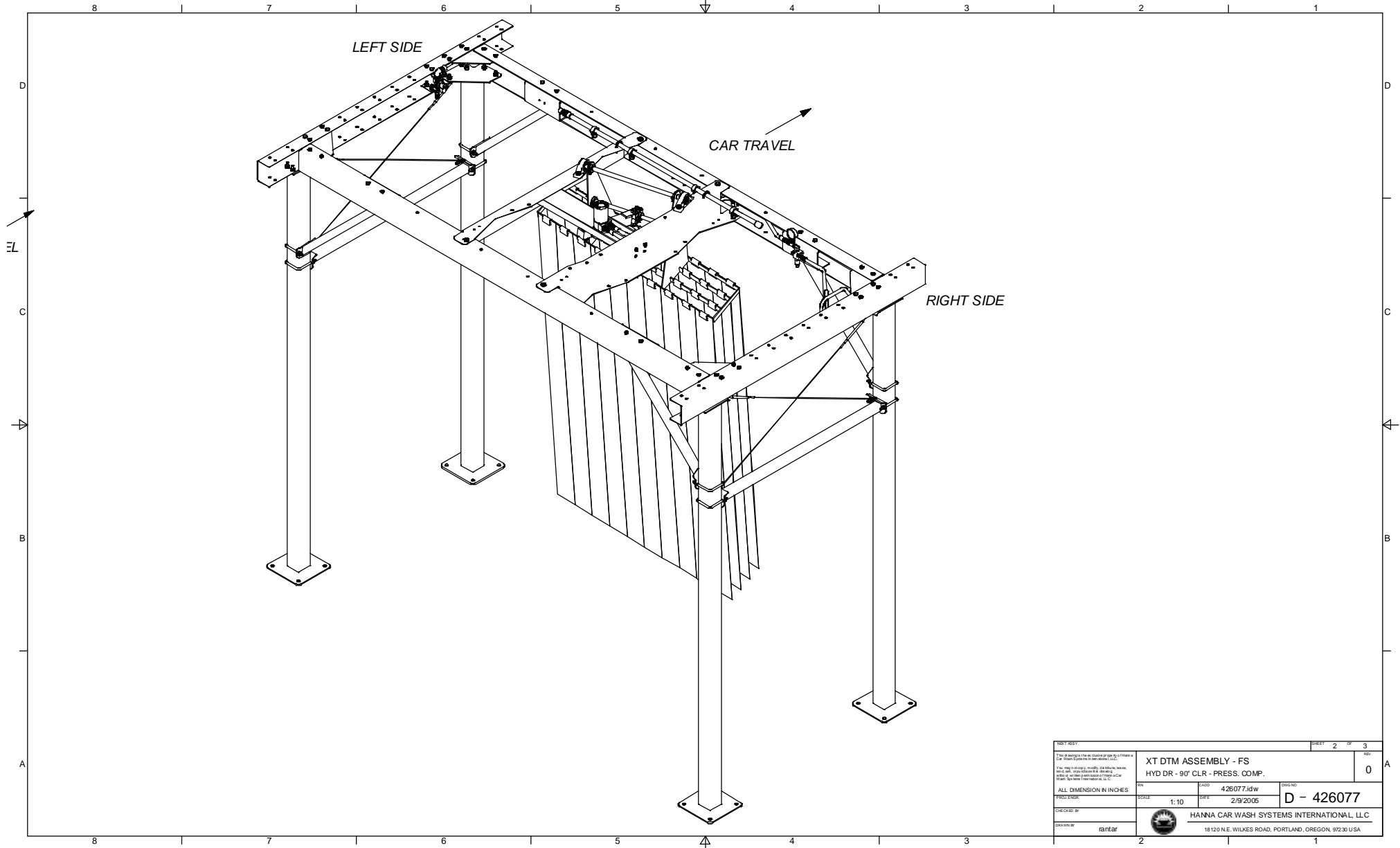

<small>THIS DRAWING IS THE PROPERTY OF HANNA CAR WASH SYSTEMS INTERNATIONAL, LLC. IT IS TO BE USED ONLY FOR THE PROJECT AND SITE SPECIFICALLY IDENTIFIED HEREIN. ANY REUSE OR MODIFICATION OF THIS DRAWING WITHOUT THE WRITTEN PERMISSION OF HANNA CAR WASH SYSTEMS INTERNATIONAL, LLC IS STRICTLY PROHIBITED.</small>		<b>XT DTM ASSEMBLY - FS</b> <b>HYD DR - 90° CLR - PRESS. COMP.</b>		SHEET 2 OF 3 0
ALL DIMENSION IN INCHES FIRST EDGE	SCALE 1:10	DWG NO. 426077.dwg DATE 2/9/2005	<b>D - 426077</b>	
CHECKED BY: _____ DRAWN BY: rbrtar	HANNA CAR WASH SYSTEMS INTERNATIONAL, LLC 18120 N.E. WILKES ROAD, PORTLAND, OREGON, 97230 USA			

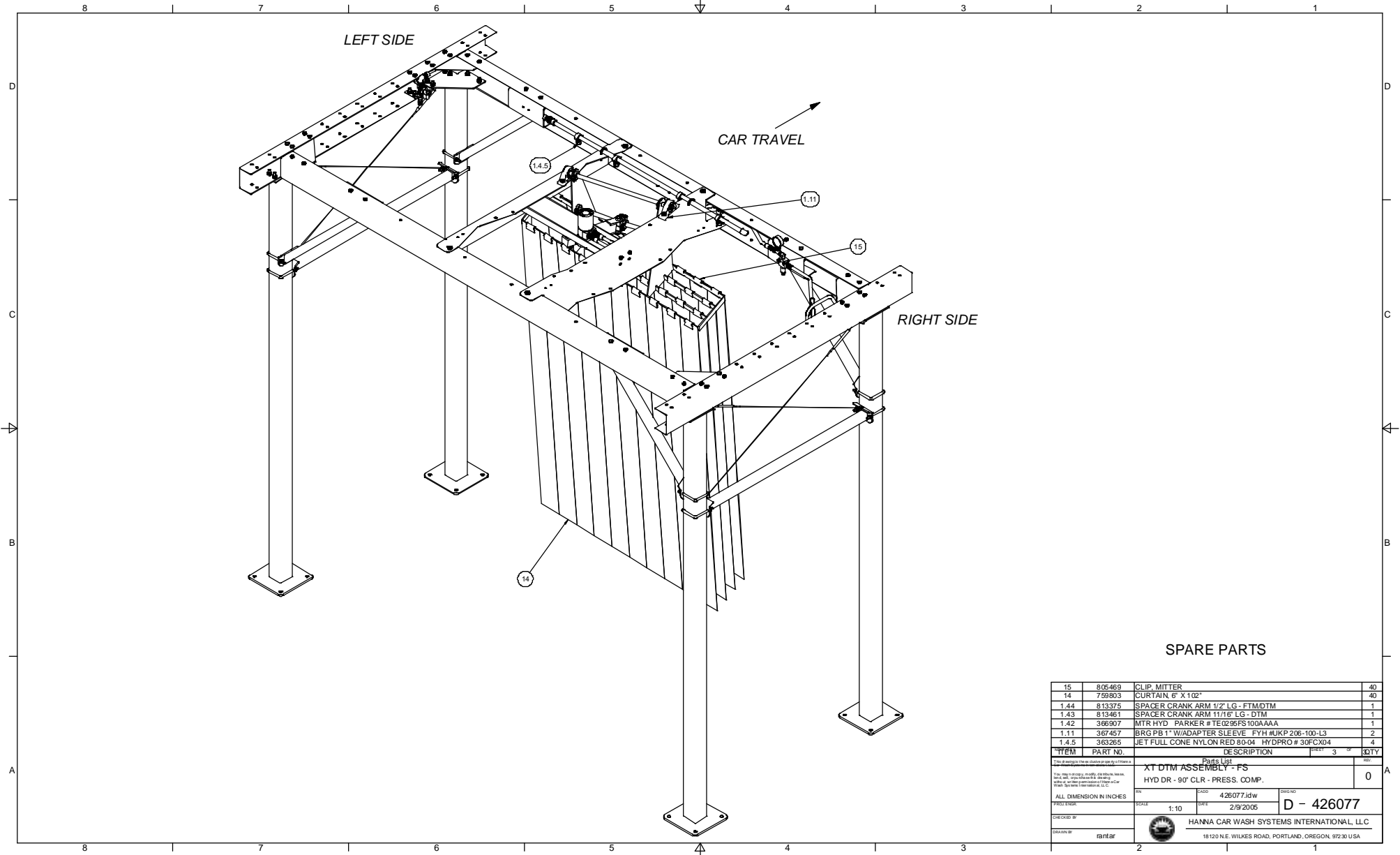

SPARE PARTS

15	805469	CLIP, MITTER	40
14	759803	CURTAIN 6' X 102"	40
1.44	813375	SPACER CRANK ARM 1/2' LG - FTM DTM	1
1.43	813461	SPACER CRANK ARM 11/16' LG - DTM	1
1.42	366907	MTR HYD PARKER # TE0295FS100AAAA	1
1.11	367457	BRG PB 1" W/ADAPTER SLEEVE FYH #JKP 206-100-L3	2
1.4.5	363265	JET FULL CONE NYLON RED 80-04 HYDPRO # 30FCX04	4
ITEM	PART NO.	DESCRIPTION	QTY
XT DTM ASSEMBLY - FS			0
HYD DR - 90° CLR - PRESS. COMP.			0
ALL DIMENSION IN INCHES		SCALE: 1:10	DATE: 2/9/2005
DRAWN BY: rbrtar		D - 426077	
CHECKED BY:		HANNA CAR WASH SYSTEMS INTERNATIONAL, LLC	
		18120 N.E. WILKES ROAD, PORTLAND, OREGON, 97230 USA	

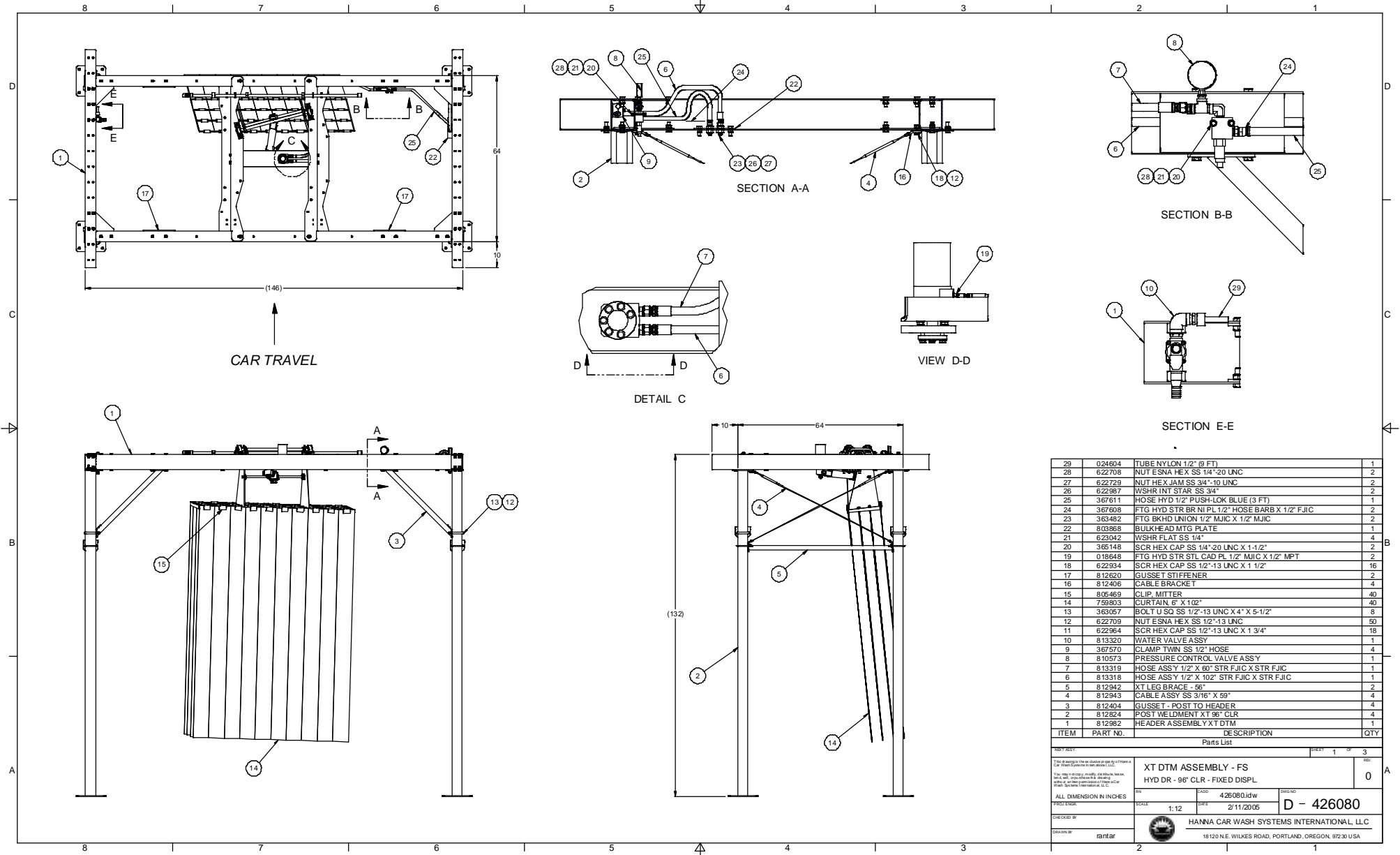

ITEM	PART NO.	DESCRIPTION	QTY
29	024604	TUBE NYLON 1/2" (6 FT)	1
28	622708	NUT ESNA HEX SS 1/4" 20 UNC	2
27	622729	NUT HEX JAM SS 3/4" 10 UNC	2
26	622987	WSHR INT STAR SS 3/4"	2
25	367611	HOSE HYD 1/2" PUSH-LOK BLUE (3 FT)	1
24	367608	FTG HYD STR BR NI PL 1/2" HOSE BARB X 1/2" FJIC	2
23	363482	FTG BKHD UNION 1/2" MJIC X 1/2" MJIC	2
22	803868	BULKHEAD MTO PLATE	1
21	623042	WSHR FLAT SS 1/4"	4
20	365148	SCR HEX CAP SS 1/4" 20 UNC X 1-1/2"	2
19	018648	FTG HYD STR STL CAD PL 1/2" MJIC X 1/2" MPT	2
18	622934	SCR HEX CAP SS 1/2" 13 UNC X 1 1/2"	16
17	812620	GUSSET STIFFENER	2
16	812406	CABLE BRACKET	4
15	805469	CLIP MITTER	40
14	759803	CURTAIN 6" X 102"	40
13	363057	BOLT U SQ SS 1/2" 13 UNC X 4" X 5-1/2"	8
12	622709	NUT ESNA HEX SS 1/2" 13 UNC	50
11	622964	SCR HEX CAP SS 1/2" 13 UNC X 1 3/4"	18
10	813320	WATER VALVE ASSY	1
9	367570	CLAMP TWIN SS 1/2" HOSE	4
8	810573	PRESSURE CONTROL VALVE ASSY	1
7	813319	HOSE ASSY 1/2" X 60" STR FJIC X STR FJIC	1
6	813318	HOSE ASSY 1/2" X 102" STR FJIC X STR FJIC	1
5	812942	XT LEG BRACE - 66	2
4	812943	CABLE ASSY SS 3/16" X 59"	4
3	812404	GUSSET - POST TO HEADER	4
2	812824	POST WELDMENT XT 96" CLR	4
1	812982	HEADER ASSEMBLY XT DTM	1

PARTS LIST

SHEET 1 OF 3

0

THIS DRAWING IS THE PROPERTY OF HANNA CAR WASH SYSTEMS INTERNATIONAL, LLC. IT IS TO BE USED ONLY FOR THE PROJECT AND SITE SPECIFICALLY IDENTIFIED HEREIN. ANY REUSE OR MODIFICATION OF THIS DRAWING WITHOUT THE WRITTEN PERMISSION OF HANNA CAR WASH SYSTEMS INTERNATIONAL, LLC IS STRICTLY PROHIBITED.

**XT DTM ASSEMBLY - FS**  
**HYD DR - 96" CLR - FIXED DISPL**

CAD: 426080.dwg    DWG NO:     
 SCALE: 1:12    DATE: 2/11/2005    **D - 426080**

CHECKED BY:    HANNA CAR WASH SYSTEMS INTERNATIONAL, LLC  
 DRAWN BY: rantar    18120 N.E. WILKES ROAD, PORTLAND, OREGON, 97230 USA

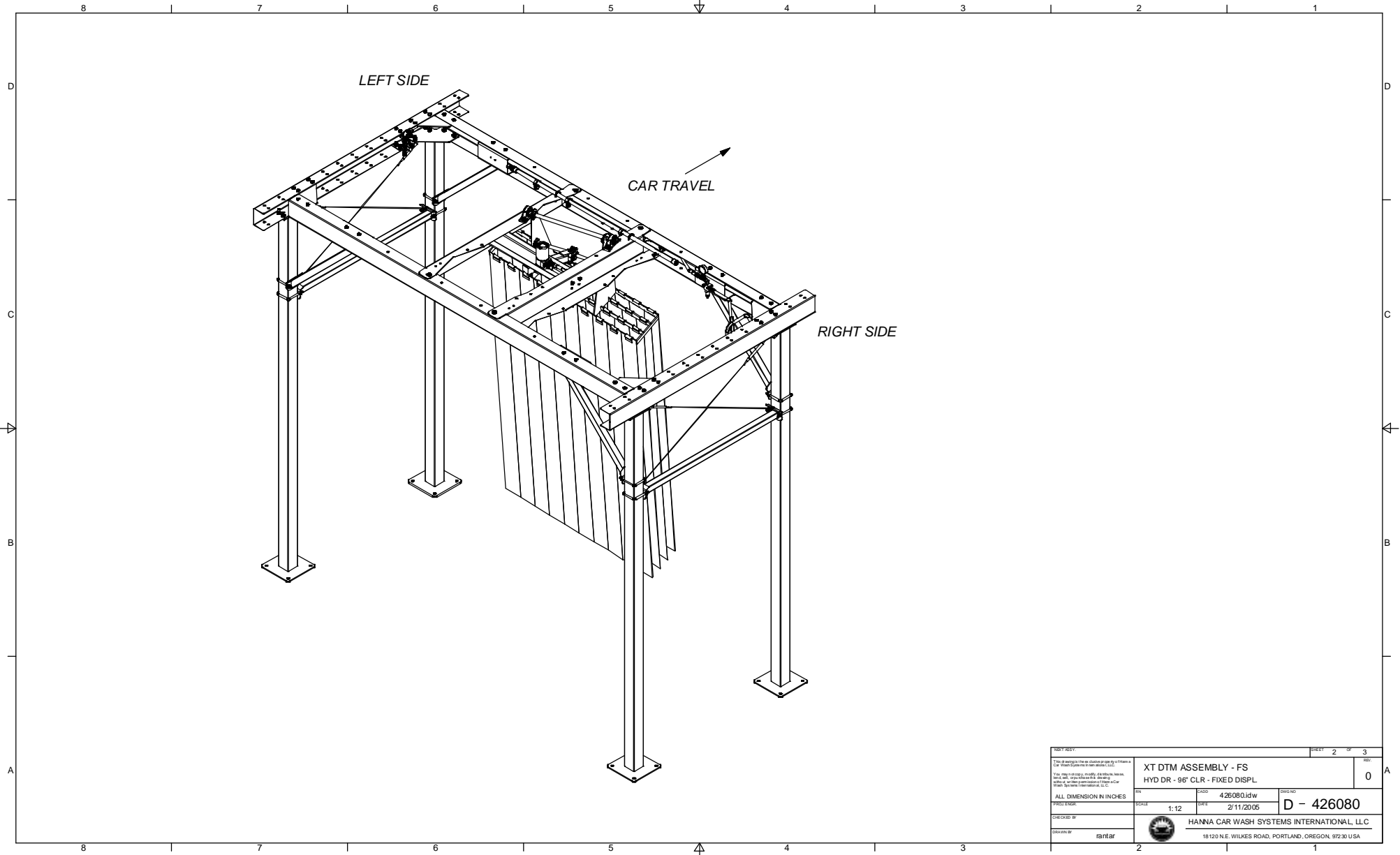

<small>THIS IS A PRELIMINARY DRAWING AND IS NOT TO BE USED FOR CONSTRUCTION. ALL DIMENSIONS ARE IN INCHES UNLESS OTHERWISE SPECIFIED. HANNA CAR WASH SYSTEMS INTERNATIONAL, LLC.</small>		<b>XT DTM ASSEMBLY - FS</b> <b>HYD DR - 96" CLR - FIXED DISPL</b>		SHEET 2 OF 3 0	
ALL DIMENSION IN INCHES FIRST EDGE	DWG NO: 426080.dwg DATE: 2/11/2005	SCALE: 1:12	D - 426080		
CHECKED BY:	HANNA CAR WASH SYSTEMS INTERNATIONAL, LLC				
DRAWN BY: rbrtar	18120 N.E. WILKES ROAD, PORTLAND, OREGON, 97230 USA				

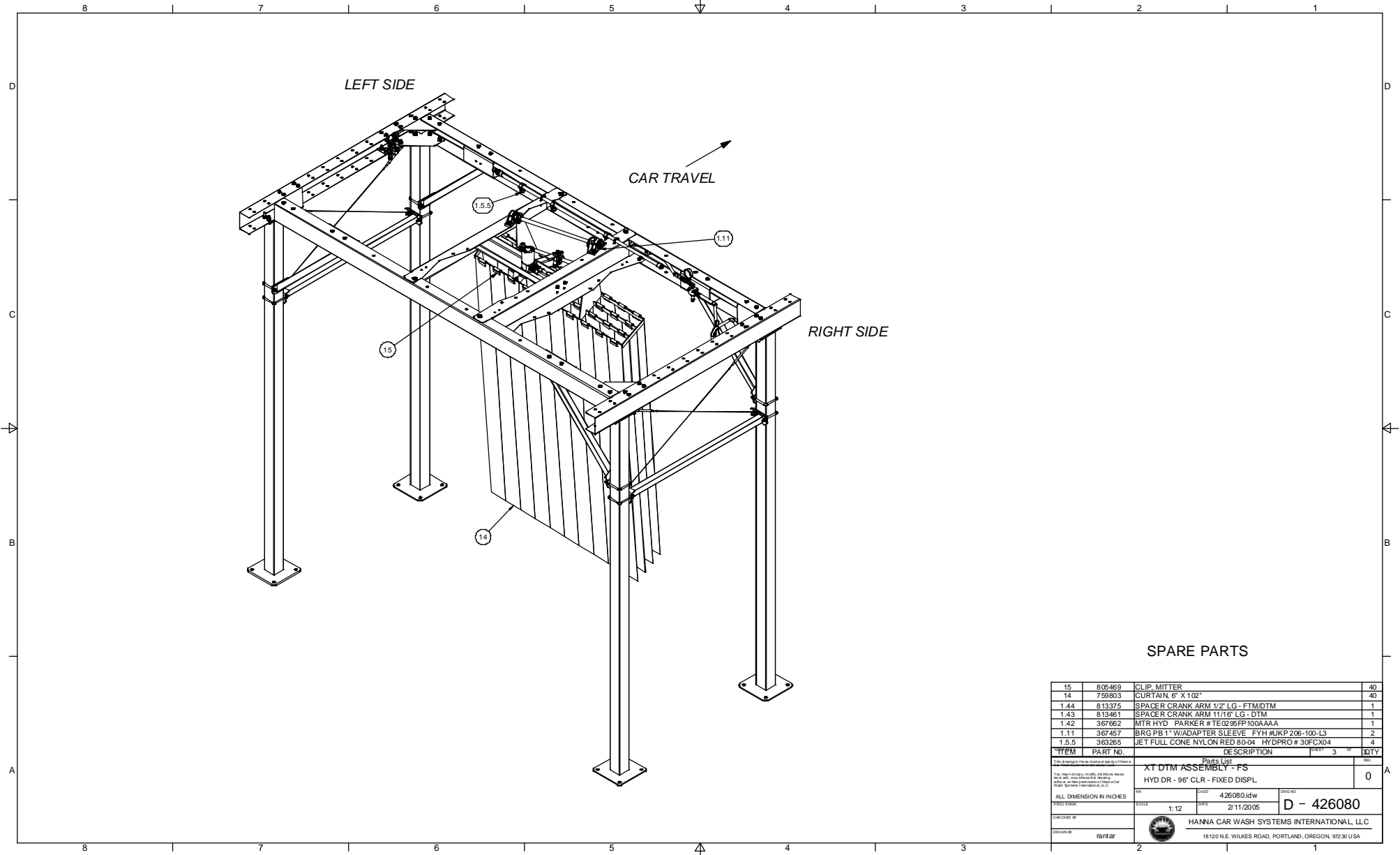

**SPARE PARTS**

15	805469	CLIP, MITTER	40
14	759803	CURTAIN 6' X 102"	40
1.44	813375	SPACER CRANK ARM 1/2' LG - FTM/DTM	1
1.43	813461	SPACER CRANK ARM 11/16' LG - DTM	1
1.42	367662	MTR HYD PARKER # TE0295FP100AAAA	1
1.11	367457	BRG PB 1" W/ADAPTER SLEEVE FYH #JKP 206-100-L3	2
1.5.5	363265	JET FULL CONE NYLON RED 80-04 HYDPRO # 30FCX04	4
<b>ITEM</b>	<b>PART NO.</b>	<b>DESCRIPTION</b>	<b>QTY</b>
XT DTM ASSEMBLY - FS			0
HYD DR - 96' CLR - FIXED DISPL			0
ALL DIMENSION IN INCHES		SCALE: 1:12	DATE: 2/11/2005
DRAWN BY: rbrtar		D - 426080	
CHECKED BY:		HANNA CAR WASH SYSTEMS INTERNATIONAL, LLC	
		18120 N.E. WILKES ROAD, PORTLAND, OREGON, 97230 USA	