

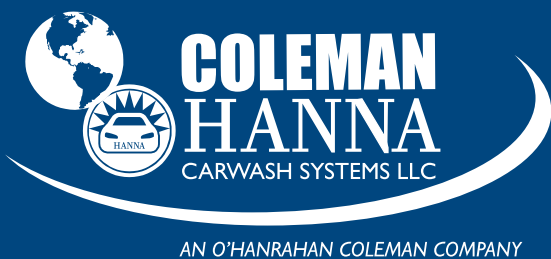

From left to right: Top - 23000 Series with Bill Acceptor, 25000 Series, 23000 Series welded onto a 24040 Vault
 Bottom - 24040, 24050, 24055 Vaults

Coin Meters & Vaults

Installation Manual



5842 W 34th St • Houston, TX 77092

1.800.999.9878 1.713.683.9878

www.colemanhanna.com



Find us on Facebook:
 /ColemanHannaCarwash



PROGRAMMING INSTRUCTIONS FOR THE SCROLLING SIGN

PUSH AND HOLD S1 FOR THREE SECONDS. This will bring up the setup unit type. Press S1 again.

This will bring up the option of either Bay or Auto. S2 will scroll through the options. Press S1 when finished. This takes you back to the Setup Unit screen.

Press S2 to take you to several options. Scroll through until you get to Bay Setup.

Press S1. This will now show Bay Setup: Setup. Press S1. This will take you to Bay Type. For use with a Swipe N Clean it should show S TYPE. To use without a Swipe N Clean it should show R TYPE.

When finished, press S1. This will take you to Config 1st Timer or Config 2nd Timer. Press S2. The Scrolling Sign will always be 2nd Timer.

When finished, press S1. This will take you to either Domestic or International. S2 will scroll through the options.

When finished, press S1. This will take you to TOKEN COINS. If you don't use tokens press S1. This will take you to BASE COINS.

S5 will advance you from one side or the other. S2 will allow you to adjust the number. Press S1 when finished.

This will take you to BASE TIME. S5 will advance you from one side or the other. S2 will advance you through the numbers.

When finished, Press S1. This will give you BONUS time. This will normally be set from your previous selection. If not, press S5 to advance you from one number to the next. S2 will scroll through the numbers.

When finished, press S1. This will take you to WASH DOWN TIME. This is set at 1 minute by default. If you want to change it, press S5 and then S2 to scroll through numbers.

When finished, press S1. This will bring you to BEEP TIME. This is set at 00:05. Leave this at this setting. Press S1 to WARNING TIME. This is set at 01:00. This is default. Press S1 to bring up the FORMAT screen. This is the last screen. It must say FORMAT 00:00. This will end setup.

Press S1 to return to the BAY SETUP: SETUP screen. Press S2 and scroll to EXIT using the S2 button. Press S1 to return to the SETUP: BAY SETUP screen. Press S2 and scroll with the S2 button until you find EXIT. Press S1 to exit out of the setup screen. It should now say ADD \$00.00 or whatever you programmed TO START.

You are now ready for operation.



METER AND SAFE INSTALLATION

1. In most cases the meter and safe installation should be accomplished before the bricking of the car wash.
2. Determine the desired set up of meter and safe combination before starting installation process.
3. Typical set up is one meter for one safe, or two meters for one safe.
4. The safes should be mounted in a very visible location. This is one of the best deterrence against theft and vandalism.
5. After determining proper heights and attaching points of meter and safes, have a qualified welder weld each item in place.
6. Install 1 ½" PVC male adapters to meter and safe openings. Route flexible PVC tubing between meter and safe. (See Diagram)
7. Install minimum ½" EMT from pre-punched hole in top of meter box to above wall height. This will provide routing for the low voltage control cable to the meter.
8. Meter and safe are installed on an individual preference. These are only guidelines. This completes the meter and safe installation procedure.



PROGRAMMING INSTRUCTIONS
NON-SWIPE-N-CLEAN 1034R TIMER

Provided below is information regarding the 1034R Timer installation.

In order to avoid any confusion, the following is a print out of the 1034R Timer:

1:	Not Used	
2:	Quarter Input	Orange/Black
3:	Horn (-)	Green/Black
4:	Horn (+)	Red/Black
5:	Safety Ground	Lime
6:	24 V Timed Output to Switch	Blue/Black
7:	Token Input	Red/Yellow
8:	Not Used	
9:	24V Common	Green
10:	24V Hot	Orange

PROGRAMMING INSTRUCTIONS:

	Bay	Vac	Frag	Sham	
Unit Type	X	X	X	X	Bay (Bay Timer), Vac (Vacuum Timer), Frag (Fragrance Unit-Pole Mount/Stand-Alone Unit), Sham (Shampoo Unit-Pole Mount/Stand-Alone Unit), Fvac (Combo Fragrance/Vacuum Unit), Svac (Combo Shampoo/Vacuum Unit),
Nationality	X	X	X	X	Domestic, International
T	X	X	X	X	Token Value in Number of Quarters
A	X	X	X	X	Base Cost
B	X	X	X	X	Base Time
C	X	X	X	X	Bonus Time
Switched			X	X	Switched, Non Switched
S			X	X	Switch Time
D			X	X	Secondary Base Cost
E			X	X	Secondary Base Time
F			X	X	Secondary Bonus Time
H	X	X	X	X	Number of Horn Beeps at 60 Seconds
I				X	Number of Blow Out Cycles
J				X	Length of Blow Out
K				X	Time Between Blow Out
W	X	X	X	X	Wash Down Time (Bay) or Vac Run Time (Vacuum)
User Password	X	X	X	X	4 Digit Password
Supervisor Password	X	X	X	X	4 Digit Password

BAY PROGRAMMING:

- Depress Mode Button until the following words appear: BAY, VAC, FRAG, SHAM, FVAC, SVAC. Use "SET" button to select "BAY" for desired function programming.
 - If you intend to use the timer in a bay – press the mode again
 - The word DOM (Domestic-US) or INTR (International) – Depress "Set" button to select nationality.
 - Press Mode again "T" will appear allowing you to program "Token" setting.
 - If you are using a separate coin acceptor for tokens only – use set button to program token value.
 - If you are not using a separate coin acceptor for tokens disregard this setting.
- Depress mode again "A" will appear – allowing you to program "Turn-On Price" (i.e. \$1.00 to start) using set button each time it is pressed and released it advances \$0.25 up to \$5.00 for turn-on.

3. Depress mode again “B” will appear allowing you to program “Time” (i.e. Base time 4:00 minutes) Using set button program time starting with minutes. When total minutes are set, use mode button to advance to seconds :00. Press mode button to advance to next digit :00
4. Press mode again “C” appears allowing you to program bonus time or time received for additional quarters. A \$1.00 for 4:00 minutes additional quarter equal 1:00 minute – using mode will advance 1 digit at a time.
5. Press mode again “H’ allowing you to program horn setting. Use set button to advance one # at a time. Ten is a good number for this.
6. Depress mode – “W” will appear allowing you to program “Wash Down Time” when using remote. Use mode to advance 1 digit at a time. *If not using Commander Remote C-1000 disregard this setting.*
 - Program User Password. Program “PIN #” with Set Button move to next digit with mode button.
 - Program Supervisor Password – program “Supervisor Password” with Set Button – move to next digit with mode button.
7. Timer is now programmed for In-Bay use.

VAC PROGRAMMING:

8. Depress Mode Button until the following words appear: BAY, VAC, FRAG, SHAM, FVAC, SVAC. Use “SET” button to select “VAC” for desired function programming.
 - If you intend to use the timer in a VAC – press the mode again
 - The word DOM (Domestic-US) or INTR (International) – Depress “Set” button to select nationality.
 - Press Mode again “T” will appear allowing you to program “Token” setting.
 - If you are using a separate coin acceptor for tokens – use set button to program token value.
 - If you are not using a separate coin acceptor for tokens, disregard this setting.
9. Depress mode again “A” will appear – allowing you to program “Turn-On Price” (i.e. \$1.00 to start) using set button each time it is pressed and released it advances \$0.25 up to \$5.00 for turn-on.
10. Depress mode again “B” will appear allowing you to program “Time” (i.e. Base time 4:00 minutes) Using set button program time starting with minutes. When total minutes are set, use mode button to advance to seconds :00. Press mode button to advance to next digit :00
11. Press mode again “C” appears allowing you to program bonus time or time received for additional quarters. A \$1.00 for 4:00 minutes additional quarter equal 1:00 minute – using mode will advance 1 digit at a time.
12. Press mode again “H’ allowing you to program horn setting. Use set button to advance one # at a time. Ten is a good number for this.
13. Depress mode – “W” will appear allowing you to program “VAC Run Time” when using remote. Use mode to advance 1 digit at a time. *If not using Commander Remote C-1000 disregard this setting.*
 - Program User Password. Program “PIN #” with Set Button move to next digit with mode button.



- Program Supervisor Password – program “Supervisor Password” with Set Button – move to next digit with mode button.
14. Timer is now programmed for vacuum use.

FRAGRANCE and FRAGRANCE/VAC PROGRAMMING:

15. Depress Mode Button until one of the following words appear: FRAG, FVAC, Use “SET” button to select desired function for programming.
16. Press Mode again - the word DOM (Domestic-US) or INTR (International) – Depress “Set” button to select Nationality.
17. Press Mode again “T” will appear allowing you to program “Token” setting.
18. If you are using a separate coin acceptor for tokens – use set button to program token value.
19. If you are not using tokens – disregard this setting.
20. Depress mode again “A” will appear – allowing you to program “Turn-On Price” (i.e. \$1.00 to start) using set button each time it is pressed and released it advances \$0.25 up to \$5.00 for turn-on.
21. Depress mode again “B” will appear allowing you to program “Time” (i.e. Base time 4:00 minutes) Using set button program time starting with minutes. When total minutes are set, use mode button to advance to seconds :00. Press mode button to advance to next digit :00
22. Press mode again “C” appears allowing you to program bonus time or time received for additional quarters. A \$1.00 for 4:00 minutes additional quarter equal 1:00 minute – using mode will advance 1 digit at a time.
23. Press mode again – the words “Switched” or “Non-Switched” will appear. Select “SET” to selected desired mode.
24. Press mode again “S” will appear allowing you to program switch time. *“Switched/Non-Switched”. Switched if you are using fragrance that cost less than vacuum and you select vacuum, the timer will require additional money be deposited and switched time is the time allowed to make additional deposit or timer reverts to fragrance and times out.* (i.e. time 30 seconds) Using set button program time starting with minutes. When total minutes are set, use mode button to advance to seconds :00. Press mode button to advance to next digit :00.
- | | | | |
|---|--------|---|--------|
| A | \$1.00 | D | \$0.75 |
| B | 4:00 | E | 0:45 |
| C | 1:00 | F | 0:15 |
25. Depress mode again “D” will appear – allowing you to program “Secondary Base Cost” (i.e. \$1.00 to start) using set button each time it is pressed and released it advances \$0.25 up to \$5.00 for turn-on.
26. Press mode again “E” appears allowing you to program secondary base time or time received for additional quarters. A \$1.00 for 4:00 minutes additional quarter equal 1:00 minute – using mode will advance 1 digit at a time.
27. Press mode again “H” will appear allowing you to program horn setting. Use set button to advance one # at a time. Ten is a good number for this.



- 28. Depress mode – “W” will appear allowing you to program “Vac Run Time” when using remote. Use mode to advance 1 digit at a time. *If not using Commander Remote C-1000 disregard this setting.*
- 29. Program User Password. Program “PIN #” with Set Button move to next digit with mode button.
- 30. Program Supervisor Password – program “Supervisor Password” with Set Button – move to next digit with mode button.
- 31. Timer is now programmed for use in the fragrance or fragrance/vac unit.

SHAMPOOER and SHAMPOO/VAC PROGRAMMING:

- 32. Depress Mode Button until one of the following words appear: SHAMP, SVAC, Use “SET” button to select desired function for programming.
- 33. Press mode again - the word DOM (Domestic-US) or INTR (International) – Depress “Set” button to select Nationality.
- 34. Press Mode again “T” will appear allowing you to program “Token” setting.
- 35. If you are using a separate coin acceptor for tokens – use set button to program token value.
- 36. If you are not using tokens – disregard this setting.
- 37. Depress mode again “A” will appear – allowing you to program “Turn-On Price” (i.e. \$1.00 to start) using set button each time it is pressed and released it advances \$0.25 up to \$5.00 for turn-on.
- 38. Depress mode again “B” will appear allowing you to program “Time” (i.e. Base time 4:00 minutes) Using set button program time starting with minutes. When total minutes are set, use mode button to advance to seconds :00. Press mode button to advance to next digit :00
- 39. Press mode again “C” appears allowing you to program bonus time or time received for additional quarters. A \$1.00 for 4:00 minutes additional quarter equal 1:00 minute – using mode will advance 1 digit at a time.
- 40. Press mode again – the words “Switched” or “Non-Switched” will appear. Select “SET” to selected desired mode.
- 41. Press mode again “S” will appear allowing you to program switch time. *“Switched/Non-Switched”. Switched if you are using shampoo that cost less than vacuum and you select vacuum, the timer will require additional money be deposited and switched time is the time allowed to make additional deposit or timer reverts to shampoo and times out.* (i.e. time 30 seconds) Using set button program time starting with minutes. When total minutes are set, use mode button to advance to seconds :00. Press mode button to advance to next digit :00.

A	\$1.00	D	\$0.75
B	4:00	E	0:45
C	1:00	F	0:15
- 42. Depress mode again “D” will appear – allowing you to program “Secondary Base Cost” (i.e. \$1.00 to start) using set button each time it is pressed and released it advances \$0.25 up to \$5.00 for turn-on.



43. Press mode again "E" appears allowing you to program secondary base time or time received for additional quarters. A \$1.00 for 4:00 minutes additional quarter equal 1:00 minute – using mode will advance 1 digit at a time.
 44. Press mode again "H" will appear allowing you to program horn setting. Use set button to advance one # at a time. Ten is a good number for this.
 45. Press mode again "I" will appear allowing you to program number of Blow Out Cycles. Use set button to advance one # at a time. 4 is a good number for this.
 46. Press mode again "J" will appear allowing you to program length of Blow Out. (i.e. time 4:00 minutes) Using set button program time starting with minutes. When total minutes are set, use mode button to advance to seconds :00. Press mode button to advance to next digit :00.
 47. Press mode again "K" will appear allowing you to program time between Blow Out. (i.e. time 2:00 minutes) Using set button program time starting with minutes. When total minutes are set, use mode button to advance to seconds :00. Press mode button to advance to next digit :00.
 48. Depress mode – "W" will appear allowing you to program "Run Time" when using remote. Use mode to advance 1 digit at a time. *If not using Commander Remote C-1000 disregard this setting.*
 49. Program User Password. Program "PIN #" with Set Button move to next digit with mode button.
 50. Program Supervisor Password – program "Supervisor Password" with Set Button – move to next digit with mode button.
- Timer is now programmed for use in the shampooer or shampoo/vac unit.

SENSORTRON

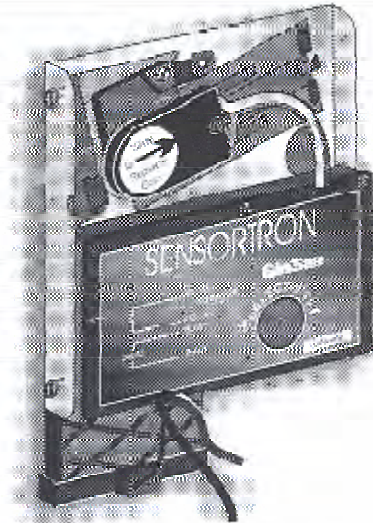

TECHNICAL INFORMATION MODEL GS-41 SENSORTRON

TO INSTALL SAMPLE COIN OR TOKEN:

1. Slide sensor coil to the right and replace plastic chip with coin or token.
2. Release sensor coil, making sure sample coin or token is held firmly in place.
3. Do not use a 1965 or 1974 quarter as a sample.

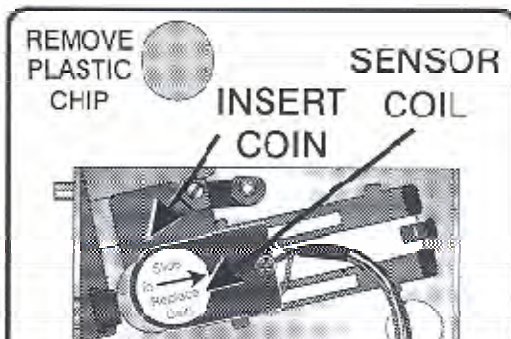

SENSORTRON WIRING:

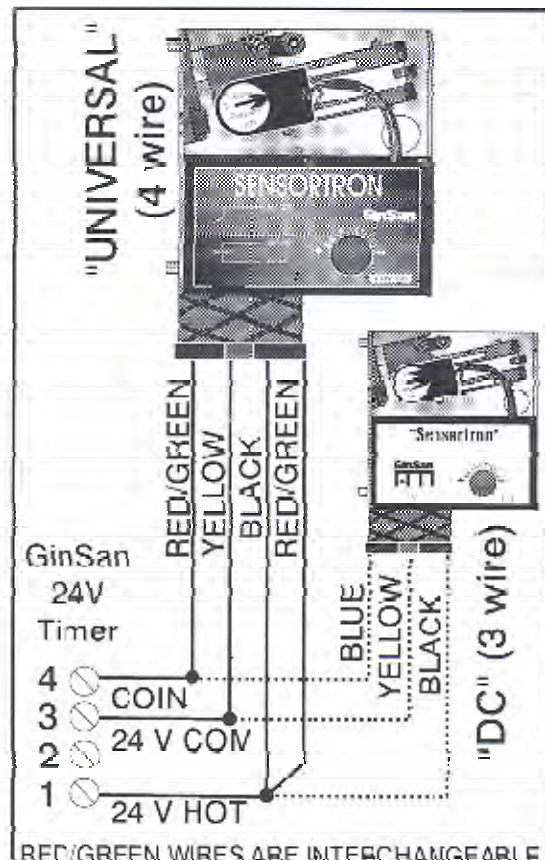

SELECTIVITY ADJUSTMENTS:

Sensortrons are preset for use with U.S. quarters.



The selectivity control is designed to enable field adjustments for closer coin scrutiny, thereby providing greater rejection of slugs.

1. Remove black rubber plug.



2. Using small screwdriver, locate adjusting slot on potentiometer (pot.).

3. Turn pot. clockwise as far as it will go.

4. Turn pot. counterclockwise (a little at a time until it rejects all unwanted coins).



5. Replace rubber plug.

When using coins smaller than a quarter (in size), the coin slot opening must be made smaller to prevent jamming.

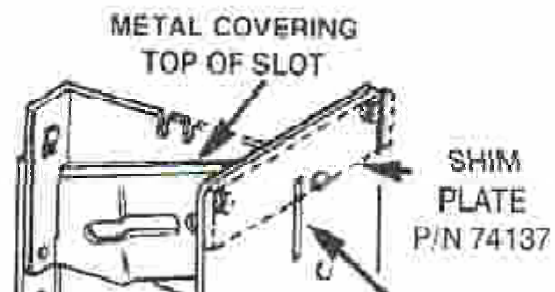

SPECIAL INSTRUCTIONS:

- Do Not allow a coin box heater to come in contact with the Sensortron.
- To interface a 24 volt mechanical coin counter with a Sensortron, order a GS-17 interface, Part Number 77060.

Problem/Symptom:

Sensortron accepts unwanted slugs.

Cause:

In 1986 the counter weight was removed from the pendulum damper on the Sensortron to correct isolated problems of coins sometimes jamming on the pendulum damper. Counter weights are available through customer service at GinSan Industries in Grand Rapids, MI.

Solution:

Turn the silver colored counter weight with star washer clockwise to attach in the mounting hole of the pendulum damper. (See drawing)

Do Not install Counter Weight unless there is a problem accepting unwanted Slugs or Coins!!!

Selectivity Adjustments may be necessary after above procedure is completed.

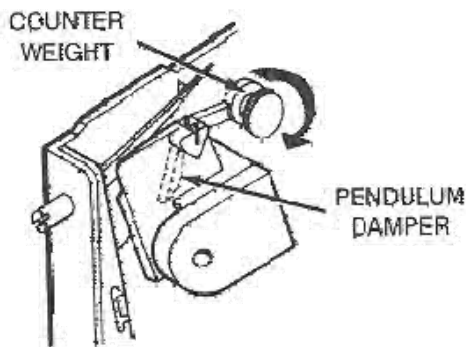

SENSORTRON® (GS-41) Warranty

GinSan Industries, Inc. warrants the GS-41 Sensortron Coin Acceptor to be free from defects in material and workmanship for a period of two (2) years from date of purchase, with proof of purchase.

This warranty does not apply to any Sensortrons which have been misused, altered, neglected, or not installed, adjusted, maintained, or not used in accordance with applicable codes and ordinances and in accordance with Manufacturer's recommendations as to

Universal Sensortron Wiring Instructions For Various Timers

Note: Red/Green wires are interchangeable.

GinSan Timer (GS-9 110 Volt) to Universal GS-41

Black wire to Terminal #5
Yellow wire to Terminal #7
Red/Green wires to Terminal #4 & #5

GinSan Timer (GS-11 110 Volt) to Universal GS-41

Black wire to Terminal #4
Yellow wire to Terminal #1
Red/Green wires to Terminal #3 & #4

D & S Timer to Universal GS-41

Black wire to 24 Hot(L1)
Yellow wire to 24 Common(L2)
Red/Green wires to 24 Common(L2) & Coin Terminal

Paraplate Timer to Universal GS-41

Black wire to -Coin Switch
Yellow wire to Jumper for 24 V AC
Red/Green wires to +Coin Switch & -Coin Switch

Keltner Timer 24 Volt to Universal GS-41

Black wire to Terminal #2
Yellow wire to Terminal #1
Red/Green wires to Terminals #2 & #4

Parker Timer to Universal GS-41

Black wire to Terminal #1
Yellow wire to Terminal #3
Red/Green wires to Terminals #1 & #4

Dixmor Digital Timer to Universal GS-41

Black wire to 24 V AC Hot (IN)
Yellow wire to 24 V AC Common (IN)
Red/Green wires to Coin Common & Coin Signal



3611 3 Mile Rd. N.W.
Grand Rapids, MI 49544

1-800-446-7267 www.ginsan.com

DP 32801

TECHNICAL SHEET

800 - 446 - 7267

Sensortron™ & Multitron™ Hook-up to Various Timers

(See Technical Booklet T/G-319 for Wiring to GinSan Timers)

Dixmor DX2000 Timer

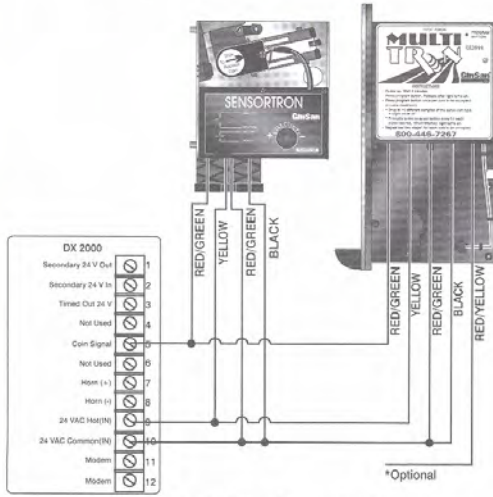

Dixmor Digital Timer

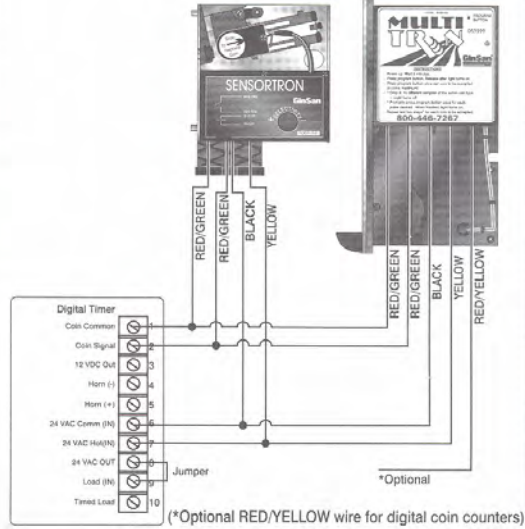

IDX Timer

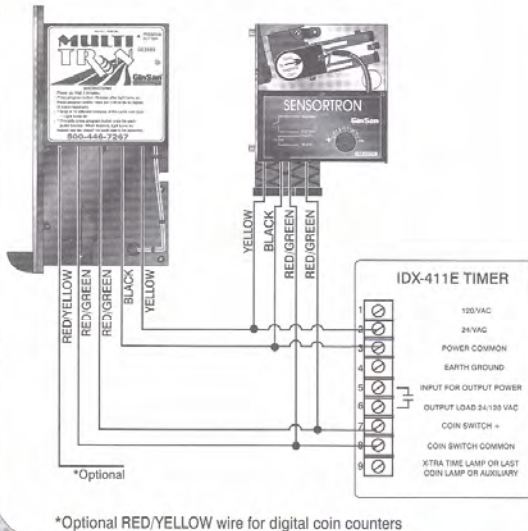

IDX LTT Timer (Little Two Timer)

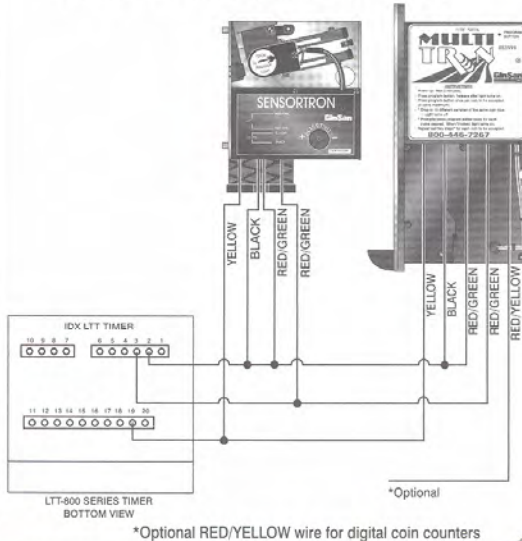

3611 3 Mile Rd. N.W.

Grand Rapids, MI. 49544-1231

Fax (616) 791-9925

GinSan

T/G-318B, pg1 of 4 9/00

TECHNICAL SHEET

800 - 446 - 7267

Sensortron™ & Multitron™ Hook-up to Various Timers

National Pride Timer

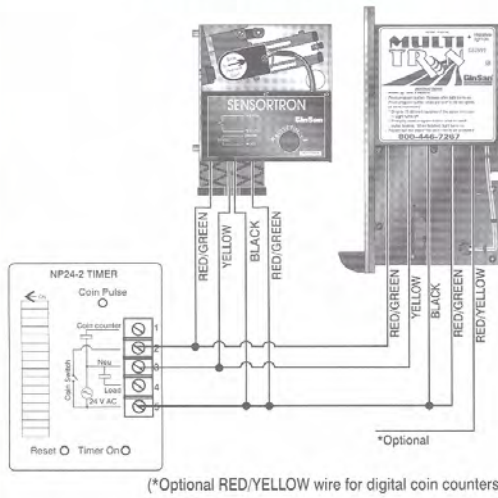

Paraplate Timer

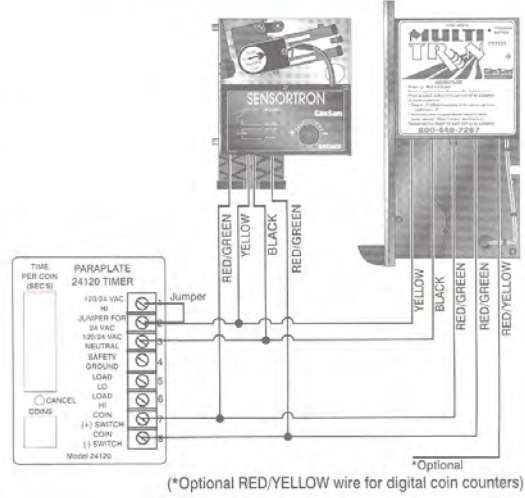

KELTNER TIMER 9-D

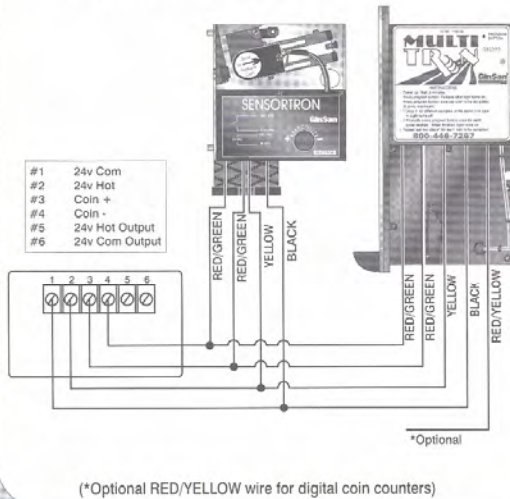

KELTNER TIMER LC-1 / RT-1

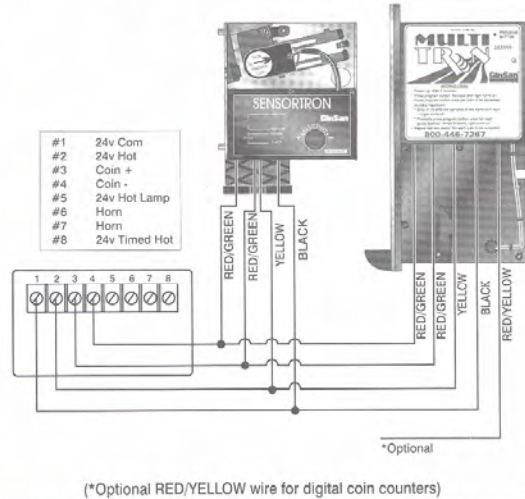

3611 3 Mile Rd. N.W.

Grand Rapids, MI. 49544-1231

Fax (616) 791-9925



GinSan

T/G-31801 p02 of 4 9/00

TECHNICAL SHEET

800 - 446 - 7267

Sensortron™ & Multitron™ Hook-up to Various Timers

D&S Timer DS203 Digital Display Timer

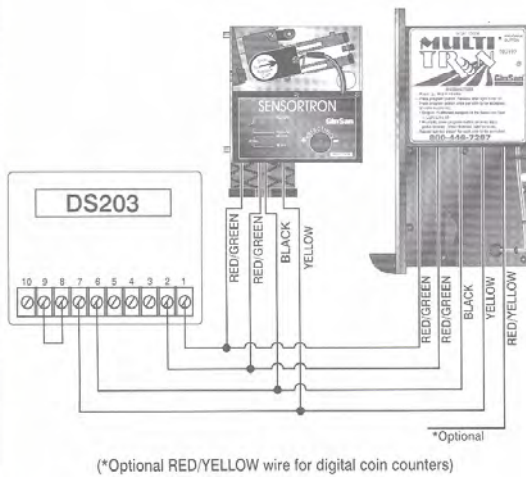

CT2000 Timer Jim Coleman

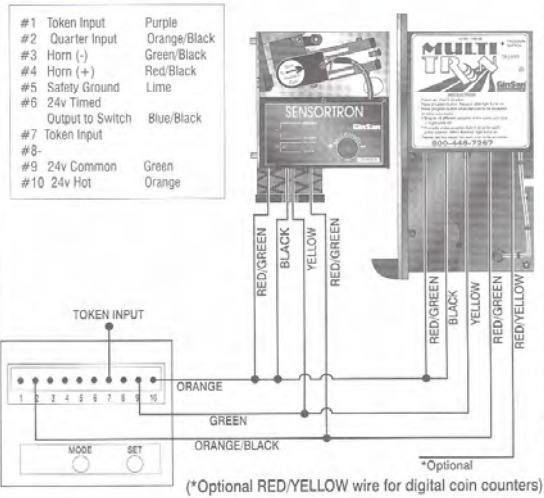

TIMERMASTER TM-5

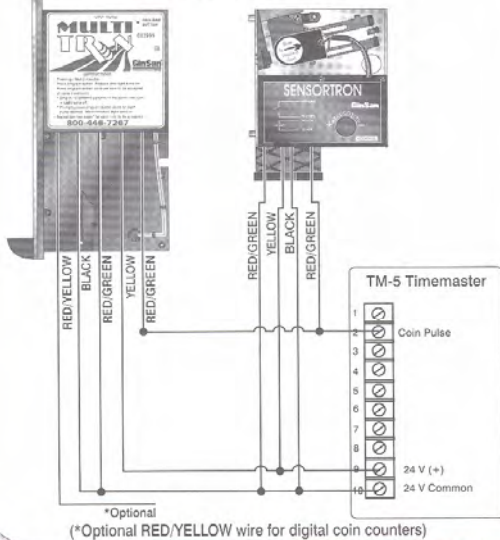

AVS Systems GP Timer

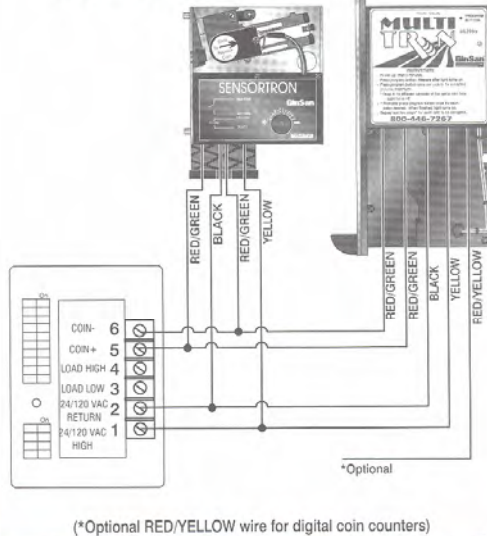

3611 3 Mile Rd. N.W.

Grand Rapids, MI. 49544-1231

Fax (616) 791-9925

GinSan

T/G-3188 pg3 of 4 9/00

TECHNICAL SHEET

800 - 446 - 7267

Sensortron™ & Multitron™ Hook-up to Various Timers

MAGIK TIMER Model MT580

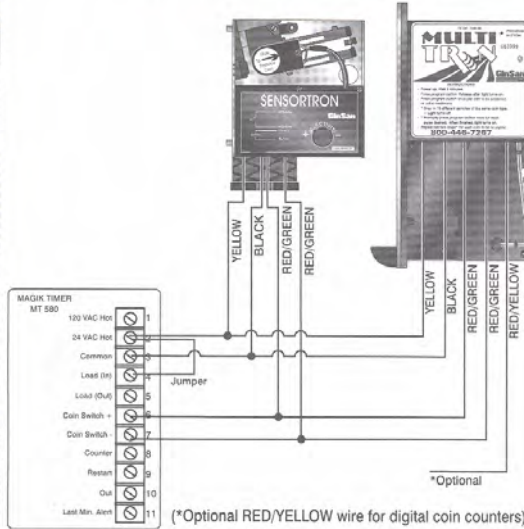

MAGIK TIMER MODEL MT 415

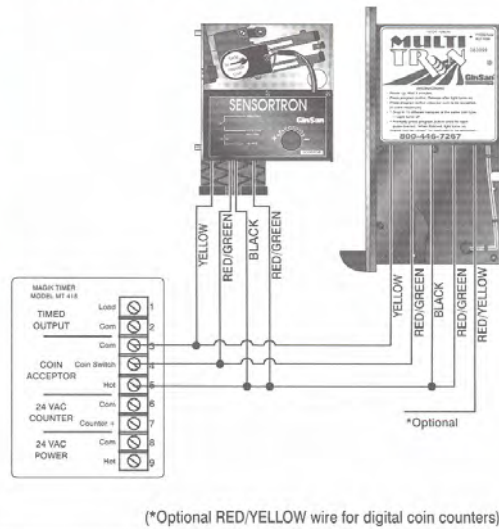

IMPORTANT
Wiring Instructions

IMPORTANT
Wiring Instructions

3611 3 Mile Rd. N.W.

Grand Rapids, Mi. 49544-1231

Fax (616) 791-9925

GinSan

T/G-318b, pg 4 of 4, 9/00

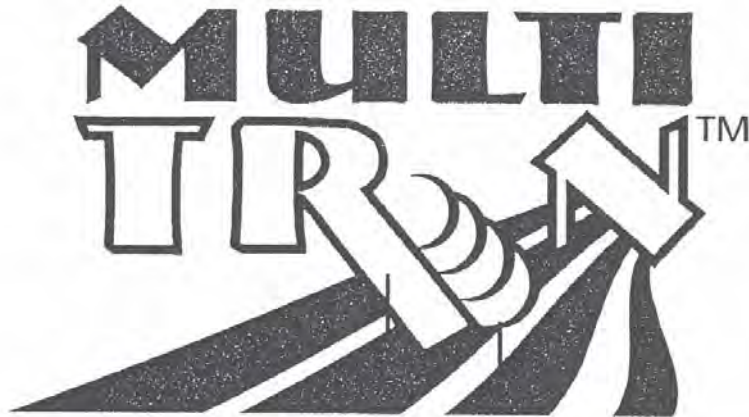

MULTI-COIN ACCEPTOR

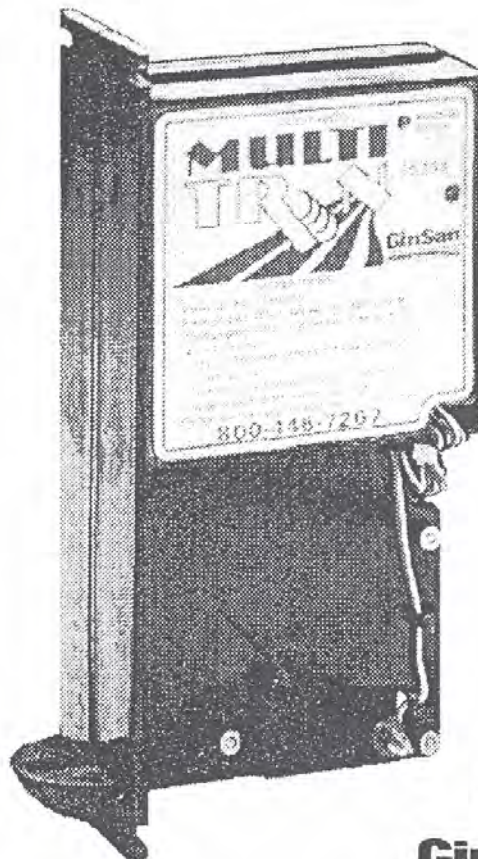

By

GinSan
CORP.

TECHNICAL INFORMATION
Patent Pending

Before Programming:

1. Select 15 samples of each different coin type to be accepted. Use a variety of years & mints to create an accurate representation of each coin. 
2. The lowest denomination of coins to be accepted will be the base value of all the others & will equal one output pulse for the Multitron.

Example: quarters(base) = \$0.25 = 1 pulse
dollar coin = \$1.00 = 4 pulses
3. To make future changes in coins to be accepted or coin value, the entire programming procedure must be repeated.
4. The Multitron is designed to accept up to 4 different coins. It also has the means to trigger a second coin output providing a convenient way to separate or track different coin types. This proves beneficial when using data collection systems, such as GinSan's DATAmate™

Outputs for the first three coins are sent via the red/green wire, while the fourth is sent via the red/yellow wire.

The output pulses are sent as follows:

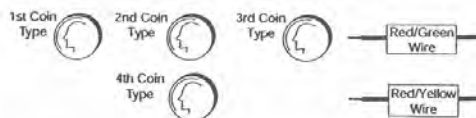













NOTE: Red/yellow wire is a transistor output and may require an interface before using with some timers.
See back for wiring instructions.

5. Once programmed, the Multitron will hold its program even when power is removed.



Programming Instructions:

6. Apply power to the Multitron and wait 2 minutes for the unit to stabilize. 

7. Press  PROGRAM button. Release  button when  light turns on.
8. Press  PROGRAM button once for each type of coin to be programmed in the Multitron. If you desire to accept four different coins, press  PROGRAM button 4 times, If 2 different coins, press  button 2 times, etc.
9. Wait 4 seconds for light to blink. Insert 15 samples of the first coin. After 15 coins have been inserted  light will turn off. Promptly press  PROGRAM button once for every output pulse desired for that coin. See step #2
10. The  light will automatically come back on after the value has been programmed. When  light turns on, repeat step 9 for the next type of coin to be accepted. After the value has been programmed wait for  light to turn back on and continue to the next coin.

NOTE: Only the amount of coins entered in

step 8 can be programmed and if any error is made you must start the entire process over.

This is done by either finishing the process and returning to step 7 or removing power during programming causing Multitron to return to its previous program.

11. When the last coin has been programmed (set in step 8) the Multitron is ready to accept coins.

SPECIAL INSTRUCTIONS
Do not allow a coin box heater to come in contact with the Multitron.

Multitron Warranty

GinSan Industries, Inc. will warrant the Multitron to be free from defects in material and workmanship for a period of two (2) years from date of purchase, with proof of purchase.

This warranty does not apply to any Multitron which has been misused, altered, neglected or not installed, adjusted, maintained, or not used in accordance with applicable codes and ordinances and in accordance with Manufacturer's recommendations as to such factors.

Basic Hook-up

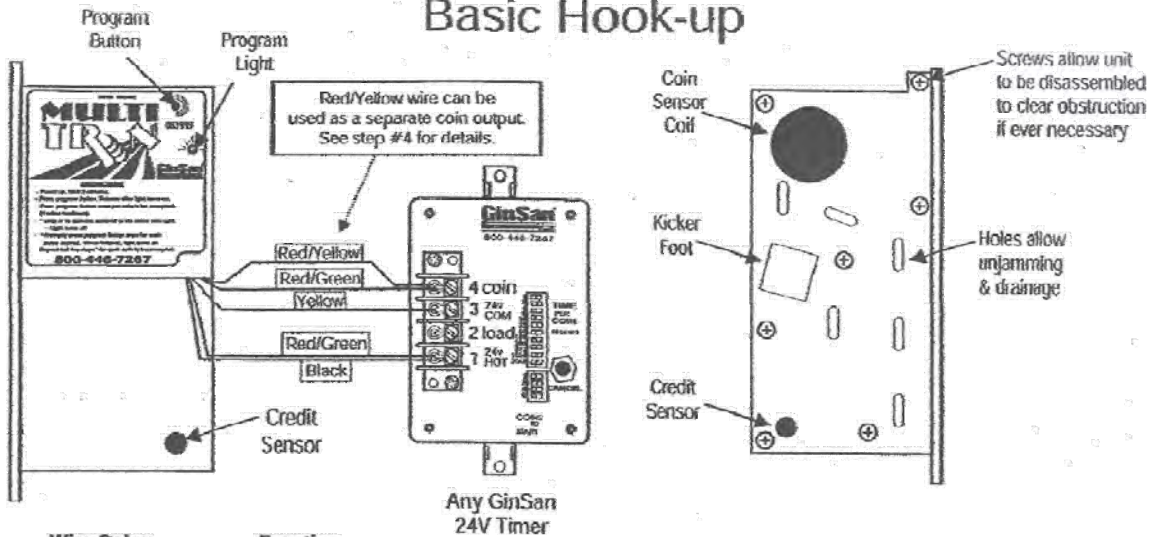

Wire Color	Function
Red / Green	N.O. contact (1Amp Max.)*
Red / Green	Relay common*
Black	24 VAC hot (Recommended supply voltage of 22-30VAC)
Yellow	24 VAC common (Recommended supply voltage of 22-30VAC)
Red/Yellow	Transistor output (100 mA DC Max.) SEE BELOW

* Red / Green wires are interchangeable.

Note:

- Outputs for the first three coins are sent via the red/green wire. The pulse for the fourth coin is sent via the red/yellow wire, which only needs to be connected if accepting 4 coins.
- The red/yellow wire is a transistor output and may require an interface before using with some timers.
- Interface P/N 77080



MultiTron™ Wiring Instructions For Various Timers

Note: Red/Green wires are interchangeable.

Red/Yellow wire can be used as a separate coin output.

See step #4 for details.

GinSan Timer (GS-9 110 Volt) to Universal GS-44

Black wire to Terminal #5

Yellow wire to Terminal #7

Red/Green wires to Terminal #4 & #5

Red/Yellow wire to Terminal #4

GinSan Timer (GS-11 110 Volt) to Universal GS-44

Black wire to Terminal #4

Yellow wire to Terminal #1

Red/Green wires to Terminal #3 & #4

Red/Yellow wire to Terminal #3

D & S Timer to Universal GS-44

Black wire to 24 Common(L2)

Yellow wire to 24 Hot(L1)

Red/Green wires to 24 Common(L2) & Coin Terminal

Red/Yellow wire to Coin Terminal

Paraplate Timer to Universal GS-44

Black wire to -Coin Switch

Yellow wire to Jumper for 24 V AC

Red/Green wires to +Coin Switch & -Coin Switch

Red/Yellow wire to + Coin Switch

Keltner Timer 24 Volt to Universal GS-44

Black wire to Terminal #2

Yellow wire to Terminal #1

Red/Green wires to Terminals #2 & #4

Red/Yellow wire not used (Requires interface)

Parker Timer to Universal GS-44

Black wire to Terminal #1

Yellow wire to Terminal #3

Red/Green wires to Terminals #1 & #4

Red/Yellow wire to Terminal #4

Dixmor Digital Timer to Universal GS-44

Black wire to 24 V AC Common (IN)

Yellow wire to 24 V AC Hot (IN)

Red/Green wires to Coin Common & Coin Signal

Red/Yellow wire to Coin Signal



3611 3 Mile Rd. N.W.

Grand Rapids, MI 49544

1-800-446-7267 www.ginsan.com

THE GOLDEN



DOLLAR
THE RIGHT CHANGE

POINT OF SALE MATERIALS ORDER FORM

Point of Sale materials for the new Golden Dollar coin are available for marketing purposes and consumer awareness at no charge. Due to inventory constraints, we reserve the right to limit shipments based on availability of materials. Allow additional time for large quantities to be processed. Please fill out and mail or fax this form to:



DOUBLE EAGLE

MARKET DEVELOPMENT COMPANY
3010 OLD RANCH PARKWAY, SUITE 205
SEAL BEACH, CA. 90740
PHONE: 877 DLR-COIN (357-2646)
FAX: 800-641-2455

CONTACT INFORMATION:

Contact Name Title
Company Name
Phone Fax
E-mail address Web site

SHIP TO: (please type or print)

Name Title
Company Name
Mailing Address
City State Zip

PLEASE SEND ME THE FOLLOWING:

Quantity	Item
8434003	P-1 Full-color Golden Dollar Sticker (1" x 1") permanent adhesive
8434004	R-1 Full-color Golden Dollar Sticker (1" x 1") removable adhesive
8434005	P-1.5 Full-color Golden Dollar Sticker (1.5" x 1.5") permanent adhesive
8434006	R-1.5 Full-color Golden Dollar Sticker (1.5" x 1.5") removable adhesive
8434007	P-3.5 Full-color Golden Dollar Sticker (3.5" x 3.5") permanent adhesive
8434008	R-3.5 Full-color Golden Dollar Sticker (3.5" x 3.5") removable adhesive
8434009	P-1.25 Full-color Golden Dollar Sticker (1.25" round coin) permanent adhesive
8434010	R-1.25 Full-color Golden Dollar Sticker (1.25" round coin) removable adhesive
8434011	C-8 Full-color Golden Dollar Static Cling (8" x 10")
8434012	C-1.5 Full-color Golden Dollar Static Cling (1.5" x 1.5")

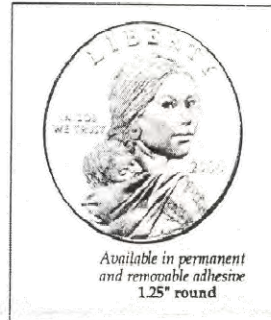



JCC PBC Operation

Key panel operation of the Jim Coleman Company, Inc. Push Button Car Wash Controller

With the Timer Off....

The PBC will light the panel selection LEDs in sequence in a clockwise direction. This light sequence continues without interruption during manipulation of the keypad. Once the user has entered a security Password Sequence then PBC enters a programming mode. The security password is currently 43210# on the BCE 1030 version of the PBC. The intention of the designers has been to make this security password programmable via the RS422 port, but this port is not currently available in the BCE 1030 design. Recommendations on how to set the security password will be taken and implemented. (Currently the security code is programmed at the factory during PBC testing).

Once the PBC has accepted the security password, the Halt LED will display a fast blink. At this point the keypad will respond to three of the keypad keys: "5", "8" and #. The # key is used to exit the programming mode, pressing this key at any time immediately transfers the PBC back into the idle state where the selection LEDs light in clockwise sequence. The "5" key is used to choose which of the selections is to be programmed (Tire Cleaner, Foaming Wax, etc.). Each time the "5" key is pressed, the selection being programmed changes (rotate around the selection panel in a clockwise direction). The selection being programmed is always indicated by the fast blinking LED. The "8" key is used to choose which of the I/Os which can be enabled when a customer chooses the current panel selection. The three I/Os which are being programmed are the Motor, the Solenoid, and the Auxiliary. Pressing the "8" key will rotate the combinations is as follows: All I/Os are off. All I/Os are on. Motor and Solenoid are on. Motor and Auxiliary are on. Solenoid and Auxiliary are on. Motor alone is on. Solenoid alone is on. Auxiliary alone is on.

In summary: The typical programming sequence for the JCC PBC is as follows:

1. Administrator will enter the security code currently 43210#.
2. If an incorrect sequence is entered, press the # key to reset the PBC and re-enter the security code.
3. Once the security code is recognized, the Halt LED will blink quickly.
4. Administrator will press or hold the "5" key until the selection LED which they wish to program is chosen.
5. Administrator will press or hold the "8" key until the combination of I/Os which they wish to have enable during user wash cycles is displayed on the PBC board mounted LEDs.
6. Administrator will repeat using the "5" key to choose the panel selection and the "8" key to choose I/O activity until they are satisfied with the system programming.
7. Administrator will press the "#" key to exit programming mode, reset the system security to the locked state, and return the PBC to its normal idle state.



With the Timer On...

The PBC will light Halt LED on the Selection panel. The user selects the desired wash function by pressing the associated selection panel key. The selection panel LED which is associated with that function will light. The I/Os which the administrator has previously programmed will be driven active by the PBC and the car wash is active.

When the user wishes to change wash functions, they press the key associated with that function and the system changes state to accommodate (The keypad is debounced so that intentional sabotage of the car wash system is not possible by repeated, quick key selections or by holding down multiple keys).

When the timer runs out the PBC automatically recognizes the loss of 24VAC and resets itself into the idle state where the selection panel LEDs light in sequence.

Document Revision: 1.01 October 7, 1998
Pertinent to PBC Hardware Revision 1.00 of BCE 1030
PBC Software Revision 1.00. of BCE 1030

COMMANDER C-1000

Remote Control Operation

NOTE:

To **CHANGE** or **RESET** the access code or wash down time, remove the plugs covering the **MODE** and **SET** switches. Depress the **MODE** switch for 6-8 seconds until a "flashing" **00:00** appears. Reprogram with the new information and replace the plugs to seal the timer.

REMOTE CONTROL OPERATION

The remote control unit will allow you to control the operation of the **TIMEMASTER** up to a distance of five feet. To control the timer, you enter the access code numbers on the number keys of the remote control while pointing the front of the remote control unit at the face of the timer display. See diagram. When the timer accepts the access code, you will hear

a short "beep" from the alert horn. If a "beep" is not heard, depress cancel (**CNCL**) and then re-enter the code slowly. You **MUST** press a function button within **7 seconds** or you will have to re-enter the access code.

REMOTE CONTROL FUNCTIONS

TEST-Enter your access code and push the **TEST** button to begin a wash down cycle. The wash down cycle will run for the amount of minutes you programmed in step 6 of the **initial set up** procedure. (In the example, you set the wash down cycle for 2 minutes.) During the wash down cycle you can cancel the remaining time by pushing the **CNCL** (cancel) button. During wash down cycle the display will show **0:FF**. (wash down cycles cannot be accumulated.)

COIN COUNT- Enter your access code, depress and **hold** the **COIN** button. The display will show the number of coins that have been inserted. If you hold this button down for more than **10 seconds**, you will reset this counter to zero. This counter can be used except during the last minute of time remaining.

TEST COUNT- Enter your access code, depress and hold the **TEST CYCLES** button. The display will show how many wash down cycles have been used. This counter cannot be re-set unless you remove the connector from the back of the timer. This counter can be used except during the last minute of time remaining.

CANCEL BUTTON- You may cancel a wash down cycle by depressing the switch. If you desire to cancel the time remaining, enter the access code and press the **CNCL** (cancel) button.

REMOTE CONTROL REPROGRAMMING OF THE TIMER

Enter your access number and push the **MODE** button. The display will flash **00:00**.

NOTES

When entering function commands or access code numbers on the remote control, press each button firmly and release it completely before pressing the next button.

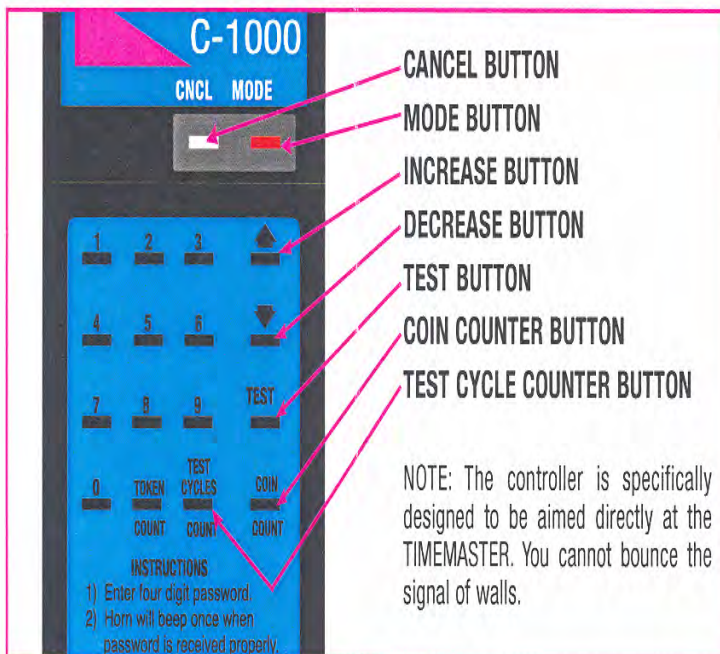

The infra-red communication system is designed to prevent improper use and sending the commands too quickly (by pressing buttons too quickly) can cause the system to reject the signal. If you do not get a “beep” response when you enter the access code, press **CNCL** and re-enter the access code. In the following steps, holding the selected button down will cause the number being changed to increase or decrease very rapidly.

Number of Coins Needed to Start the Wash - Press the **MODE** switch once. The display shows **A:01**. You may select any number between 1 and 20 by using the increase button (up arrow) or the decrease button (down arrow).

Wash Seconds - Press the **MODE** switch once. The display shows **b:00**. You may select any number of seconds between 0 and 59.

Wash Minutes - Press the **MODE** switch once. The display shows **CO:XX** (XX is the number of seconds that you set in the previous step). You may select any number of minutes between 0 and 9. By using the values entered in the last two steps, the timer calculates the proper amount of time to give a customer for each additional quarter he inserts.

Alert Horn - Press the **MODE** switch once. The display shows **d:00**. You may select any number of seconds

between 0 and 59. When one minute of time remains, the alert horn will sound. This setting determines how long the horn will sound.

Number of Coins

Depress the **MODE** switch once. The amount to start wash cycle will show in the window. Allow 7 seconds for the **TIMEMASTER** to reset from programming before adding the coins.

TIMEMASTER has now been reprogrammed and is again ready for customer use. Note that you cannot change your access code or the time allowed for a wash down cycle by using the remote control.

TROUBLESHOOTING

There are no customer repairable parts inside the timer. If the remote control functions are erratic, first replace the batteries in the remote control unit. If that does not eliminate the problem, shut off the power source, then unplug the connector from the back of the timer for at least 30 seconds, re-insert the connector and restore power to the unit to clear the programming. You must reprogram the initial set-up functions after removing and replacing the connector.

JIM COLEMAN COMPANY

5842 W. 34th Street
Houston, TX 77092
713-683-9878
800-999-9878
FAX: 713-683-9624

MEI

Bill Acceptor

Series 2000
with MEI
FlashPort

AE2400 Series Installation Guide

GENERAL INFORMATION

This document contains information for installing the MEI AE2400 Series Bill Acceptor. This Bill Acceptor is designed to fit into the standard bill acceptor opening provided by amusement machine manufacturers. It mounts on either the existing four mounting studs located in the amusement machine or on the mounting bracket provided in various mounting kits.

Features of the AE2400 include:

- \$1, \$2 and \$5 bill acceptance
- Four Direction bill acceptance
- Re-programmable Flash Memory (Flashport™)
- Coupon configuration
- Lighted bezel (On Compact model only)
- Easy Access to the bill path even while mounted
- Diagnostic LED (see back of unit)
- Enhanced security
- Factory set to four pulses per dollar



Figure 1

FLASHPORT™

The AE2400 Bill Acceptor with MEI Flashport™ has the ability to update software in the field by flash downloading.

INTERFACE OPTIONS

The 24V and 115V AE2400 supports pulse interfaces.

Depending upon the model you order, one of the following harnesses will be supplied:

250079022 - 115 VAC Power / Enable Cable (Pulse Interface)

250071021 - 24 VAC Power / Enable Cable (Pulse Interface)

For further information on either interface harnesses or mounting kits, please contact your supplier or MEI Service Center.

INSTALLATION INSTRUCTIONS

1. Set Bill Acceptor option switches. See Figure 2.

Note: When you receive the product, all switches are off. This will automatically enable the options as follows:

- Accept \$1,\$2, and \$5 dollar bills.
- Four way accept.
- High Security accept.
- 50ms on/50 ms off pulse (short pulse).
- Four pulses per dollar.
- Always enabled.



Important note: Placing any switch ON will override the above options, and the Bill Acceptor will operate according to the switch settings label! (See Figure 2)

NOTE: The unit may be configured with the attached coupon rather than using the option switches. *For coupon configuration, turn all option switches OFF and proceed to Coupon Configuration instructions on page 4.*

SWITCH DESCRIPTION	
1,2	Combination of these two switches selects number of enabled bill directions.
3	Position allows either acceptance or security to be maximized.
4,5,6	Individual switches enable or disable corresponding bill denomination.
7	Position allows for either one (1) or four (4) pulses per dollar. One pulse = 50ms on/50ms off
8	Position allows for either Always Enable , acceptance at all times or Harness Enable , acceptance by way of controller.

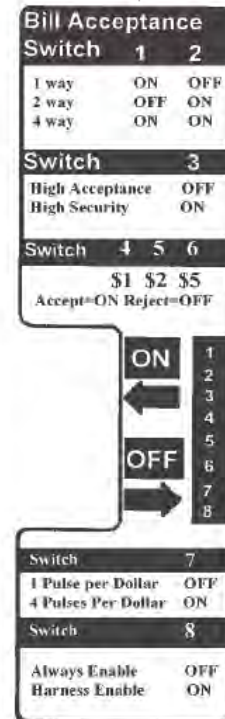

Figure 2

2. Remove power from the entire machine.

3. Install the AE2400 onto the Bill Acceptor mounting studs and through the mounting hole of the amusement machine. Secure using the appropriate hardware.

INSTALLATION INSTRUCTIONS (CONTINUED)

4. **Connect the AE2400 to the appropriate interface harness.** A power cord (available separately - MEI Part No. 01-12-139-4- 110V only) may be used for supplying power to the bill acceptor and for routing pulse credits to a coin switch.

Forcing harness(es) into bill acceptor will cause pins to bend or break!

On 110V units, attach the enclosed tie-wrap to the mounting stud closest to the harness connection on the Bill Acceptor. Pull tie-wrap tightly around harness wires, including ground wire (equipped with ring terminal), to provide strain relief. **See Figure 3.**

5. On 110V units, place the ring terminal of the grounding wire to an earth ground location within the machine. Secure with the appropriate hardware.

IMPORTANT NOTE TO OEMs: Step 5 must be performed prior to Machine Dielectric Voltage - Withstand (Hi-Pot) Testing.

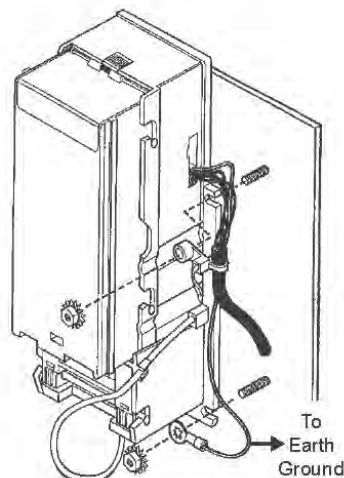

Figure 3

6. **Apply power to the machine.**

Observe that the LED status indicator on the back of the AE2400 is ON and NOT flashing. This condition indicates that the unit is ready to accept bills.

- If the light is OFF, check to ensure that power has been applied.
- If the light is flashing, refer to the label located on the back of the magazine for a description of diagnostic codes.

7. **Check operation**

- Insert a \$1 bill and observe that it is accepted and stacked.
- Repeat for other enabled bills.
- Insert a \$5 bill and verify that proper credits have been established.
- If the machine display indicates that a credit was missed; reconfigure the AE2400, using coupon, for **LONG PULSE** (60ms on/300ms off).

8. **Remove bills and check status**

- Instructions for bill removal are located on a label at the back of magazine.
- Verify that the LED status indicator remains steady ON.

COUPON CONFIGURATION (ALL SWITCHES OFF)

1. Carefully remove the coupon from this Installation Guide. Copies are usable if made on a standard, carbon-based, non-color copier, AND if cut to match the size of the attached coupon. **(Coupon can be found on page 11.)**
2. Fill out the coupon using a #2 pencil. Fill in one block for each line. Do not mark the back of the coupon.

Section 1 - Bill Direction Enable one or two-way (face-up) or four-way acceptance (all directions).

Section 2 - Bill Denomination Fill in one block for each denomination. Select High Accept for maximum bill acceptance. Select High Security for a higher level of discrimination. Select OFF to reject bills of that denomination.

Section 3 - Pulse Timing Select either SHORT, LONG pulse timing.

Section 4 - Pulses per Dollar Most machines use four pulses per dollar.

Section 5 - Bezel Lights Select ON or Flashing (Compact Bezel only).

3. Locate the service button on the back of the unit (refer to Figure 4). depress the button once to enter coupon set-up mode. Depressing again will exit the mode.

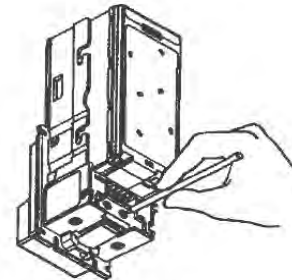

Figure 4

4. Insert coupon and verify settings were accepted.

ACCEPTED: Coupon returned immediately and LED flashes 10 times when coupon pulled out.

REJECTED: Coupon returned after ten seconds. LED flashes number of times corresponding to section improperly filled out. Example: Six flashes for improper section six. If rejected, review instructions or try new coupon.

CLEANING

The AE2600 series will not need cleaning as often as magnetic sensing Bill Acceptors. If cleaning is required, use a soft cloth moistened with mild, non-abrasive detergent. Refer to label located on the back of the magazine for cleaning instructions.

CHECK LIST

<p>Unit dead (won't power up).</p>	<p>1. Harness(es) may be loose, not properly connected, or bent pins.</p> <p>2. Check source voltage to ensure that power is being supplied to the bill acceptor.</p>
<p>Red message light flashing twice (disabled from mech / VMC).</p> <p>NOTE: If flashing other than twice refer to label located on back of the magazine.</p>	<p>1. Check settings on the bill acceptor to ensure that proper interface options are being used. If only the 9 pin power cable is being used make sure that switch # 8 is in the off position (Always Enable)</p>
<p>Unit takes a bill, but won't credit.</p>	<p>1. Check to ensure that the proper interface has been selected (long / short pulse).</p>

PINOUT INFORMATION FOR 30 PIN CONNECTOR

Connector Assignment for the 9 pin Cable

- Pin 1 NEUTRAL INHIBIT
- Pin 2 NEUTRAL ENABLE
- Pin 3 HOT ENABLE
- Pin 4 115 VAC HOT (POWER)
- Pin 5 24 VAC HOT (POWER)
- Pin 6 115 / 24 VAC NEUTRAL
- Pin 7 CREDIT RELAY (N.O.)
- Pin 8 CREDIT RELAY (COMM.)
- Pin 9 Reserved

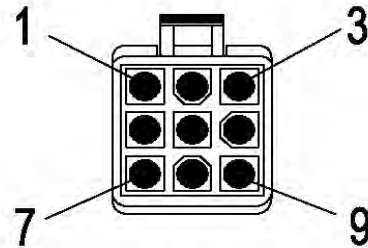

9 - Pin Mating Connector
AMP "MATE-N-LOCK" (9) pin
AMP Part#172161-1 Shell
AMP Part#170364-1 Male Pin
#22 Gauge Wire Recommended

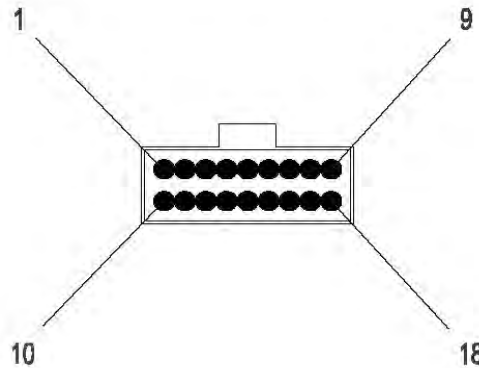

18 - Pin Mating Connector
AMP "MODU" (18) pin MT receptacle
AMP Part#102398-7 IDC Connector Housing
AMP Part#102536-7 Back cover
AMP Part#102681-4 Front cover
#22 Gauge Wire Recommended

PINOUT INFORMATION FOR 30 PIN CONNECTOR (CONT.)

1	2	3	4	5	6	7	8	9	10	11	12	13	14	15
16	17	18	19	20	21	22	23	24	25	26	27	28	29	30

115 Volt AC Model

24 Volt AC / MDB Model

GAMING PINOUTS ONLY!

• Pin 1	CREDIT RELAY, Common	Same
• Pin 2	RESERVED	CREDIT RELAY N.O.
• Pin 3	RESERVED	24 VAC HOT (Power)
• Pin 4	115 VAC NEUTRAL (Power)	RESERVED
• Pin 5	RESERVED	KEY
• Pin 6	KEY	RESERVED
• Pin 7	CREDIT-PULSE_NOT	Same
• Pin 8	INTERRUPT_NOT	Same
• Pin 9	SERIAL /PULSE_NOT	Same
• Pin 10	LOW_LEVEL_GND	Same
• Pin 11	SERIAL DATA OUT	Same
• Pin 12	NOT USED	Same
• Pin 13	NOT USED	Same
• Pin 14	NOT USED	Same
• Pin 15	NOT USED	Same
• Pin 16	CREDIT RELAY, Normally Open	DC RETURN
• Pin 17	RESERVED	Same
• Pin 18	RESERVED	Same
• Pin 19	KEY	RESERVED
• Pin 20	115 VAC HOT (Power)	24 VAC NEUTRAL (Power)
• Pin 21	EARTH GROUND	KEY
• Pin 22	OUT-OF-SERVICE_NOT	Same
• Pin 23	RESERVED	Same
• Pin 24	ACCEPT ENABLE_NOT	Same
• Pin 25	OUT OF SERVICE POWER	Same
• Pin 26	SEND_NOT / SERIAL DATA IN	Same
• Pin 27	RESERVED	Same
• Pin 28	RESERVED	Same
• Pin 29	RESERVED	Same
• Pin 30	RESERVED	Same



Configuration Coupon

Electronic copies of this manual will not have the coupon included. Please contact MEI if you need a configuration coupon

Microcoin QL

Quantum Leap

Instruction Manual

Installation Instructions

- 1) Install or replace long drop bracket on faceplate
- 2) Coin cup may need to be removed and re-attached in order to mount faceplate
- 3) Place Microcoin QL into the bracket and secure with lockable brace
- 4) The two holes on the lockable brace are designed to fit over the screw heads on the back of the QL coin mechanism

Wiring Instructions

Note 1: The Blue wires are interchangeable

Note 2: Dixmor timer users should skip to 4

- 1) Connect the Black and a Blue wire to the 24 VAC
- 2) Connect the Yellow wire to the Neutral
- 3) The other Blue wire (see note 1) connects to the timer coin pulse
- 4) Dixmor Timers only:
Connect Black wire to 24 VAC
Connect Yellow and a Blue wire to Neutral
Connect the other Blue wire to timer coin pulse

Programming Instructions

Note 1: Coins that are pre-programmed should not be programmed a second time.

Note 2: Programmed coins can be turned on/off with out re-programming; Use Enable or Disable.

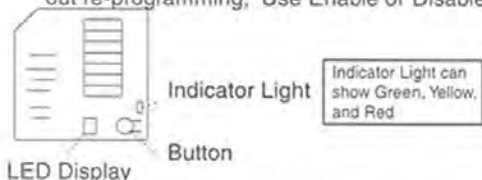

- 1) Press Button 3 times. Indicator light will show yellow flashing. LED will show "1" to represent category number 1
- 2) Pressing the Button a second time will program the coin to the next category #, up to 5
- 3) When the appropriate category is showing on the LED, drop 10 different samples through the acceptor.
- 4) When the 10th coin has been sampled the Indicator light is a solid yellow
- 5) Press Button once. LED will read "0", this is the value
- 6) Press the Button one time for every 0.25 increment the token is worth, ie, "4" gives the token a \$1.00 (Press the Button 6x and the LED will read "6", the token value will be \$1.50)
- 7) When the appropriate value is assigned, press and hold the Button for 2 full seconds
- 8) When the Button is released the Indicator Light will show solid green



- 9) Test the coin acceptor. When complete note the token and value on the side of the Microcoin QL

Disable

Used to disable a coin temporarily or for long periods of time

- 1) Press Button 2 times, Indicator Light will flash red
- 2) Drop coin one time, Ind. Light will show solid green

Enable

Used to reactivate a coin, not required for programming

- 1) Press Button 1 time, Indicator Light will flash green
- 2) Drop coin one time, Ind. Light will show solid green

Trouble Shooting Guide

Problem	Possible Cause	Action
All coins rejecting	No Power, no ind. light	Check incoming voltage
	Low Voltage	Monitor Voltage
	Water in coin path	Allow to dry
	Programming mode interrupted	Return to programming mode and follow guide to reprogram most recent coin, if this mode is started and not completed all coins rej.
One coin rejecting	Coin disabled	Enable coin
	Not programmed	Program coin
	Slightly different coin "look alike" coin	Reprogram coin using 10 different samples Coins is actually different and can be accepted by programming on add'l category
Timer not counting	24 v. / common reversed	Refer to wiring section
Coin jam	Full coin box	Empty box and QL
	QL sitting crooked	Reinsert into bracket
	Coin path obstructed	Remove foreign object

Microcoin QL Warranty

Two year parts warranty from date shipped from factory
One year labor warranty from date shipped from factory
Repair or replacement at factory option
Damage due to improper wiring, corrosion, vandalism, or water damage is not covered for any reason
Customer is responsible for the freight charges regardless of cause or outcome

Please include information for all warranties and service as to the nature of the problem, daytime phone #, return shipping address and any other pertinent information.

Model X-10 X-Mark Xeptor



SMART MULT-COIN AND ENCODED TOKEN ACCEPTOR



The model X-10 X Mart Xeptor is a multi-coin acceptor which can be field programmed to distinguish and accept any of up to six coins or tokens, including the X-Mark optically encoded tokens sold exclusively by IDX. Multi-coin acceptance offers the possibilities of mixing promotional tokens with standard tokens. It's coin release lever with opening coin chute will make coin jams a pain in the past. It's built-in-multi-color indicator LED provides operational status and field diagnostic information. It's forward thinking smart communication and field programmability options make it ideal for the coming generation of smarter equipment.

- Distinguishes and accepts any of up to six different coins or tokens
- Reads and validates multiple X- Mark encoded tokens
- Diameter range: .880" to 1.500" (23mm to 38mm)
- Slide on water resistant access covers
- Built-in coin release and opening chute
- New coin type can be learned or programmed in the field
- Multi-color indicator LED for operational status and field diagnostics

IDX INC.

401 West Main Street
El Dorado, AR 71730

800-643-1109 870-862-2051 FAX: 870-862-5978

<http://biz.ipa.net/xmark>

WIRING INFORMATION - X -10 / MA800

BT800 - BT900 TIMER CONNECTIONS

MA800 X-10:	BT800/902
YELLOW:	PIN #1
BLACK:	PIN #2
BLUE:	PIN #3

LTT800 TIMER CONNECTIONS

MA800 X-10	LTT802
YELLOW:	PIN #1
BLACK:	PIN #2
BLUE:	PIN #3

BT800 - BT902 TIMER CONNECTIONS

MA800 X-10	BT800/902
YELLOW:	PIN #1
BLACK:	PIN #2
RED/GREEN:	PIN #3
RED/GREEN:	PIN #2

LTT800 TIMER CONNECTIONS

MA800 X-10	LTT802
YELLOW:	PIN #1
BLACK:	PIN #2
RED/GREEN:	PIN #3
RED/GREEN:	PIN #2

LED5/TM5/CT2000 CONNECTIONS

MA800 X-10	
YELLOW:	#10 Orange
BLACK:	#9 Green
RED/GREEN:	#10 Orange
RED/GREEN:	#2 Orange/Blk

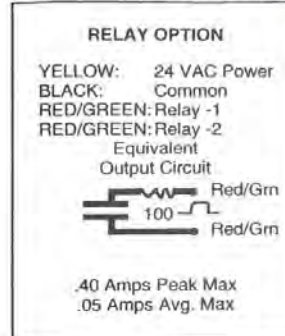
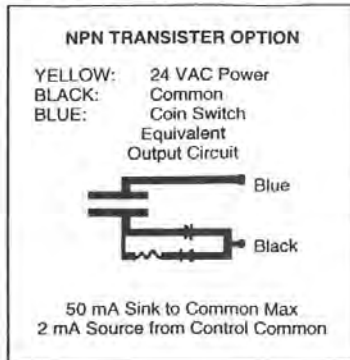

IDX AT-411 TIMER
24 VAC #2 Terminal - Yellow Wire
24 VAC #3 Terminal - Black Wire
#7 Terminal - Blue

IDX AT-401 TIMER
24 VAC #1 Terminal - Black Wire
24 VAC #2 Terminal - Yellow Wire
#3 Terminal - Blue Wire

D & S TIMER (OLD TYPE)
24 Hot (L1) Terminal - Black Wire
24 Common (L2) Terminal - Yellow Wire
Switch Terminal - Blue Wire

D & S TIMER (NEW TYPE)
24 VAC Hot (L1) Terminal - Yellow Wire
24 VAC Neutral (L2) Terminal - Black Wire
Coin Switch + Terminal - Blue Wire

PARAPLATE TIME
24 VAC #2 Terminal - Yellow Wire
24 VAC #3 Terminal - Black Wire
#7 Terminal - Blue Wire

GINSAN TIMER 24 VOLT AC
24 VAC #1 Terminal - Black Wire
24 VAC #3 Terminal - Yellow Wire
#4 Terminal - Blue Wire

PARKER TIMER 24 VAC
24 VAC #1 Terminal - Black Wire
24 VAC #3 Terminal - Yellow Wire
#4 Terminal - Blue Wire

Hook up to other Mfg. Timers
Call Factory

IDX AT-411 TIMER
24 VAC #2 Terminal - Yellow Wire
24 VAC #3 Terminal - Black Wire
#7 Terminal - Red/Green Wire
#8 Terminal - Red/Green Wire

IDX AT-401 TIMER
24 VAC #1 Terminal - Black Wire
24 VAC #2 Terminal - Yellow Wire
#3 Terminal - Red/Green Wire
#1 Terminal - Red/Green Wire

D & S TIMER (OLD TYPE)
24 Hot (L1) Terminal - Black Wire
24 Common (L2) Terminal - Yellow Wire
Switch Terminal - Red/Green Wire
Coin Terminal - Red/Green Wire

D & S TIMER (NEW TYPE)
24 VAC Hot (L1) Terminal - Yellow Wire
24 VAC Neutral (L2) Terminal - Black Wire
Switch Terminal - Red/Green Wire
Coin Terminal - Red/Green Wire

PARAPLATE TIMER
24 VAC #2 Terminal - Yellow Wire
24 VAC #3 Terminal - Black Wire
#7 Terminal - Red/Green Wire
#8 Terminal - Red/Green Wire

GINSAN TIMER 24 VOLT AC
24 VAC #1 Terminal - Black Wire
24 VAC #3 Terminal - Yellow Wire
#4 Terminal - Red/Green Wire
#1 Terminal - Red/Green Wire

KELTNER TIMER 24 VAC MODEL 9D
24 VAC #1 Terminal - Black Wire
24 VAC #2 Terminal - Yellow Wire
#3 Terminal - Red/Green Wire
#4 Terminal - Red/Green Wire

PARKER TIMER 24 VAC
24 VAC #1 Terminal - Black Wire
24 VAC #3 Terminal - Yellow Wire
#4 Terminal - Red/Green Wire
#1 Terminal - Red/Green Wire



MODEL X-10 SET UP AND TEST PROCEDURE SET UP PROCEDURES FOR LEARNING COINS AND / OR TOKENS

YOU HAVE THREE COMPONENTS IN THE UNIT TO DO THIS PROCEDURE

1. TEST LEARN BUTTON
2. SWITCH WITH 16 POSITIONS
3. FLASHING MULTI COLOR LED

#0 POSITION ON THE SWITCH IS THE NORMAL RUN POSITION
#1 POSITION THROUGH #6 POSITIONS ARE FOR DIFFERENT TYPE COINS OR TOKENS
#7 POSITION IS TEST FOR EEPROM CHIP
#8 POSITION IS TEST ON COIN PASSAGE SENSORS
#9 POSITION IS TEST FOR CALIBRATION
#A POSITION IS TEST FOR CALIBRATION
#B POSITION IS TEST FOR COIN DIAMETER
#C POSITION IS TEST FOR COIN DIAMETER
#D POSITION IS TEST FOR COIN DIAMETER
#E POSITION IS TEST FOR TYPE OF METAL
#F POSITION IS TEST FOR TYPE OF METAL

PROCEDURE FOR LEARNING COIN (SWITCH IN POSITION 0 THE LED IS GREEN, UNIT IS READY)

EXAMPLE: PLACE SWITCH IN POSITION #6. PRESS THE LEARN BUTTON FOR THE NUMBER OF PULSES YOU WANT FOR THIS TOKEN OR COIN. THEN DROP THE TOKEN OR COIN THROUGH THE ACCEPTOR SIX TIMES. THE MULTI-COLOR LED SHOULD FLASH AND THEN TURN STEADY RED. THE TOKEN OR COIN IS NOW LEARNED. NOW RETURN THE SWITCH TO THE #0 POSITION.

TO LEARN ANOTHER TOKEN OR COIN, PROCEED TO SWITCH POSITION #5 AND DO THE SAME PROCEDURE AS ABOVE.

PROCEDURE FOR DE-LEARNING COINS OR TOKENS

EXAMPLE: PLACE LEARN SWITCH IN THE POSITION YOU WANT TO DE-LEARN

- #1. PRESS THE TEST LEARN BUTTON ONE TIME, THEN TURN THE SWITCH COUNTER CLOCK WISE TO THE #0 POSITION AND WATCH FOR THE MULTI-COLOR LED TO FLICKER. AT THIS TIME THE X-10 HAS DE-LEARNED THE TOKEN OR COIN.

PROCEDURE FOR TESTING EEPROM

EXAMPLE: PLACE SWITCH IN POSITION #7 THE MULTI-COLOR LED SHOULD BE GREEN, IF LED FLASH RED/GREEN EEPROM IS BAD

PROCEDURE FOR TESTING REFLECTIVE SENSORS

EXAMPLE: PLACE SWITCH IN POSITION #8 THIS TEST IS NOT REQUIRED AT THIS TIME

PROCEDURE FOR TEST CALIBRATION.

EXAMPLE: PLACE THE SWITCH IN POSITION #9. FOLD A WHITE PIECE OF PAPER FOUR THICKNESS. PLACE IT INTO COIN SLOT. THEN PRESS THE TEST LEARN BUTTON, THE MULTI-COLOR LED SHOULD FLASH RED/GREEN THEN TURN A BRIGHT ORANGE WHEN CALIBRATION IS COMPLETE

PLACE THE SWITCH IN POSITION A: DO THE SAME AS POSITION #9

PROCEDURE FOR COIN DIAMETER TEST

EXAMPLE: PLACE SWITCH IN POSITION B: WITH THE FOLDED WHITE PAPER IN THE COIN SLOT, PULL THE PAPER UP UNTIL THE MULTI-COLOR LED TURNS GREEN. THIS TEST THE LOWER EYES.

PLACE SWITCH IN POSITION C: DO THE SAME TEST AS POSITION B. THIS TEST THE CENTER EYES.

PLACE SWITCH IN POSITION D: REMOVE THE WHITE PAPER AND THE MULTI-COLOR LED SHOULD TURN GREEN. THIS TEST UPPER EYES.

PROCEDURES FOR METAL TEST.

EXAMPLE: PLACE SWITCH IN POSITION E: WITH NO COIN IN THE UNIT THE MULTI-COLOR LED SHOULD BE GREEN. PLACE A COIN OR A TOKEN IN THE UNIT INSERTED APPROXIMATELY HALF WAY IN THE COIN SLOT. THE MULTI-COLOR LED SHOULD TURN ORANGE. THIS SHOWS THE UNIT TEST OK.

PLACE SWITCH IN POSITION F: PERFORM THE SAME TEST AS IN POSITION E. WHILE PERFORMING TEST IN POSITION E OR POSITION F WITH NO COIN OR TOKEN PRESENT AND THE MULTI-COLOR LED FLASHES RED/GREEN TWICE PER SECOND OR TURNS RED THE UNIT IS NON-FUNCTIONAL.

SET UP AND TEST ARE NOW COMPLETE

Models MA-800 And X-10 Coin Learn & Field Test Procedure



COIN LEARN PROCEDURE

- Slide the front cover up and identify the three controls to be used in this procedure:
 - Red push button near center bottom. (used to input the number of credit pulses)
 - 16 position rotary switch to the right of the push-button. (#0 is normal RUN position, #1 - #6 are for learning each of 6 possible coin types that can be accepted)
 - LED indicator half way up on the right side. (Green in RUN mode, red in LEARN mode)
- Turn the rotary switch to one of the LEARN positions #1 - #6 (for example, pick #3 for learning the 3rd coin type) and observe the LED turns red to indicate it is now ready to learn.
- Push the red button once for each credit pulse you wish to have issued for this coin. For example, a \$1 coin would require 4 credit pulses if you are also accepting \$0.25 coins for one credit pulse.
- Slide the cover back on the unit to make sure outside light does not interfere with the sensors.
- Show the unit 6 samples of the coin by depositing them into the acceptor as usual. It is best to use 6 different coins since there are typically slight variations from coin-to-coin.
- After the 6th sample coin is deposited, the LED will flash red-green a few times to indicate the LEARN procedure is complete and the coin parameters are stored in memory.
- Slide the front cover open again and turn the rotary switch back to position #0 and observe the LED turning green. Check that you have not accidentally turned it too far to position #15 which is a field test function position in which it will not accept coins.
- Slide the front cover back down and you should now be able to accept the new coin.

COIN DE-LEARN PROCEDURE

- Slide the front cover up and turn the rotary switch to the coin # position you wish to DE-LEARN.
- Push the red button once to initiate the LEARN sequence.
- Turn the rotary switch back to position #0 without depositing any coins to signal the unit that you wish it to erase the parameters for this coin. The LED will flash red-green to indicate completion.
- Slide the front cover back down.

FIELD TESTS & DIAGNOSTICS

Normal operation in switch position #0 is shown by a green LED. If the LED is flashing yellow or alternately red-green, it indicates a malfunction has been detected. Some malfunctions can be corrected in the field. See below.

GATE RELAY TEST (rotary switch #0)

Press the red button to activate the gate relay. If not normal, it may be physically obstructed or its wire unplugged.

INDUCTIVE METAL SENSOR TESTS (rotary switch #E, EF)

Turn the rotary switch to positions #E and #F to test the inductive sensor. Normal LED color is green. A red color indicates either there is metal in front of the inductive sensors or the circuit is malfunctioning.

DIAMETER OPTICS SENSOR TESTS (rotary switch #B, #C, #D)

Turn the rotary switch to positions #B, #C, and #D to test the diameter thru-beam optical sensors. Normal LED color is green. A red or orange color indicated either there is an object or dirt blocking one of these three sensors and cleaning of the coin chute is required, or the circuit is malfunctioning.

X-MARK CODE OPTICS SENSOR CALIBRATION (rotary switch #9, #A for Model X-10 only)

Fold a piece of white paper twice (to 4 thicknesses) and insert it into the center of the coin chute. Turn the rotary switch to position #9 (front side optics) and press the red button. The unit will use information gathered to calibrate the sensitivity of its reflective sensors for reading the X-Mark optical code on tokens. The LED should be an orange color after calibration. Repeat for switch position #A (rear side optics).

CREDIT SENSOR TEST (rotary switch #8)

Function not available at this time . . . ignore.

MEMORY TEST (rotary switch #7)

Turn the rotary switch to positions #7 to test the validity of memory. Normal LED color is green. A red color indicates that memory is corrupted. It may be possible to correct this by re-learning the coins. If not, the memory chip is bad.