

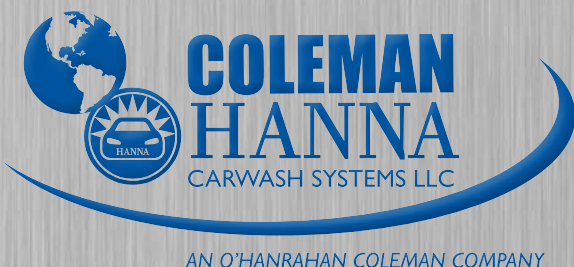

Central Vacuum System

Service Manual



5842 W 34th St, Houston, TX 77092
1.800.999.9878 • 1.713.683.9878
www.colemanhanna.com



Find us on Facebook:
[/ColemanHannaCarwash](https://www.facebook.com/ColemanHannaCarwash)

Hanna Full Service Vacuum



Table of Contents

Introduction	4
Central Vacuum	5
Dual Turbo Vacuum	6
Vacuum Can	7
Producer Adjustments	8
Impeller Adjustments	9
Motor Control Diagram	10
Electrical Code	11
Producer & Parts Break Down	12, 13
Turbo & Impeller Parts Break Down	14, 15
Vacuum Manifold	16
Manifold Accessories	17

INTRODUCTION

Hanna Vacuums come in two basic styles; 1) the Standard Full Service Vacuum available in a variety of motors and bag configurations. 2) Dual Turbo configuration , one tank with a variety of HP motors, 5 to 20 HP. All Hanna Vacuums are especially designed for high volume operation and extended use.

Equipment Function

Hanna vacuums are designed to maximize cleaning efficiency for cleaning vehicle interiors including seats, floor mats, ash trays, etc. These vacuums are not designed for exterior wet use (for example cleaning the bed of a pickup truck).

Equipment Design Features

Hanna vacuum cleaners are suitable for indoor and outdoor use in all types of weather. Vacuums are equipped with their own manifold systems which can be tailored to each customers needs. Standard Full Service Vacuum units (5, 10, 15, 20 hp) provide flexible coupling between the turbines and the motor which eliminates excessive vibration and motor bearing wear. Standard motor mounting allows for easy maintenance and replacement. Flexible coupling enables the motor or the turbine to be serviced independently. All vacuums feature easy access to filter bags and dust containment drawers.

Vacuum Operation

With the Standard Full Service Vacuums, a multistage horizontal turbo impeller removes dust and debris from the interior of the vehicle. A flexible hose transports the waste to the vacuum filter tank for collection and easy removal.

Hanna Full Service Vacuum

Hanna's Full Service Vacuum is the model of the car wash industry. The vacuums are heavy duty, powerful and capable of strong suction at each of the hose drops. The powerful suction speeds up the interior cleaning, enabling an employee to clean front and rear floors, ashtrays and crevices in minimal time. The vacuum is reliable and easy to maintain. It is easy to clean and has an opening where the interior bags can be inspected, shaken or changed.

Hanna's Full Service Vacuums come in 5, 10, 15, or 20 hp. The 5 hp is compatible with a two hose manifold. The 10 hp is compatible with 4 hose drops. The 15 hp is compatible with 6 hose drops. The 20 hp up to 8 drops.

- 5 hp Vacuum
- 10 hp Vacuum
- 15 hp Vacuum
- 20 hp Vacuum

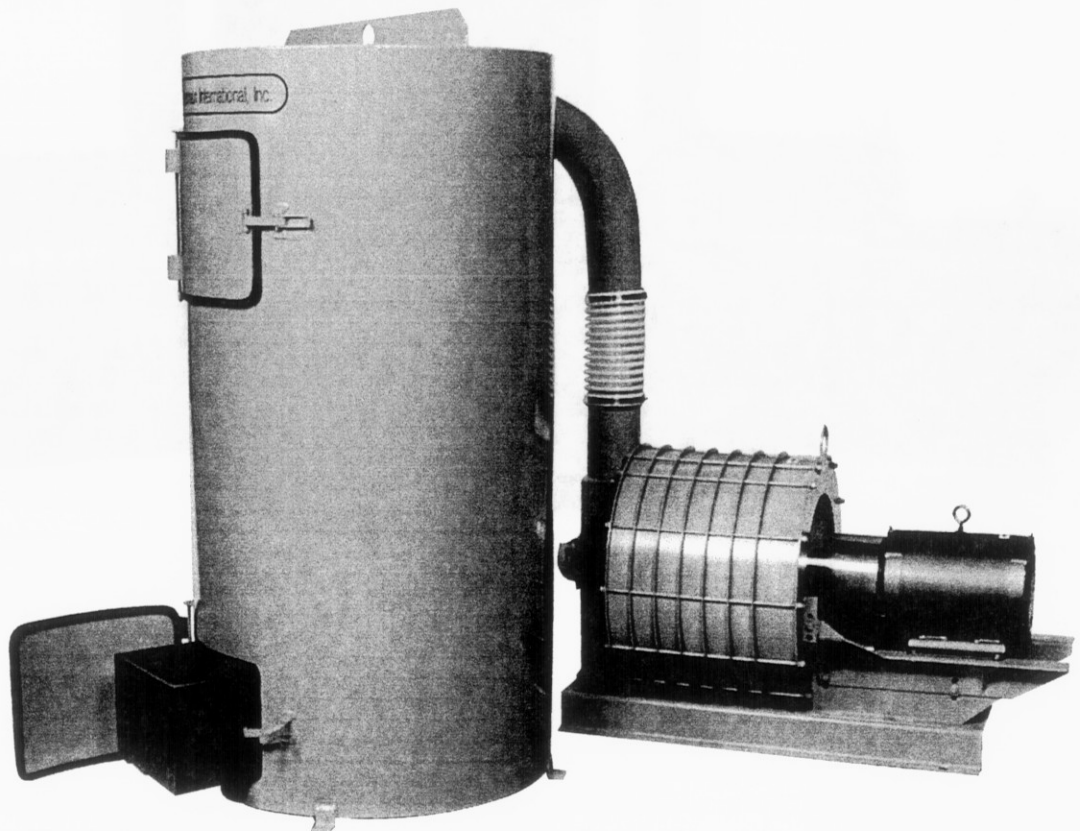

CENTRAL DUAL TURBO
One Tank Configuration

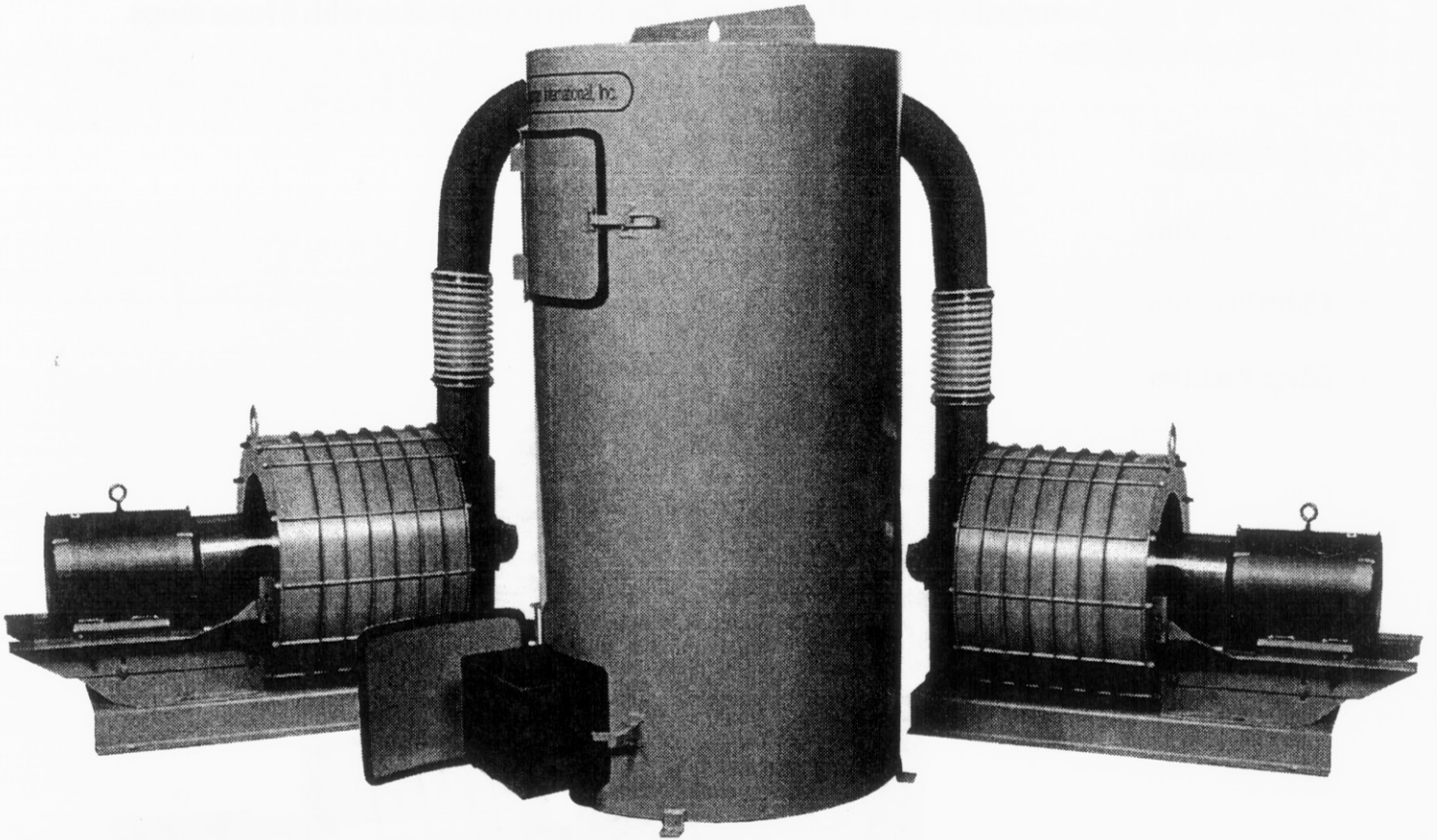

VACUUM CAN

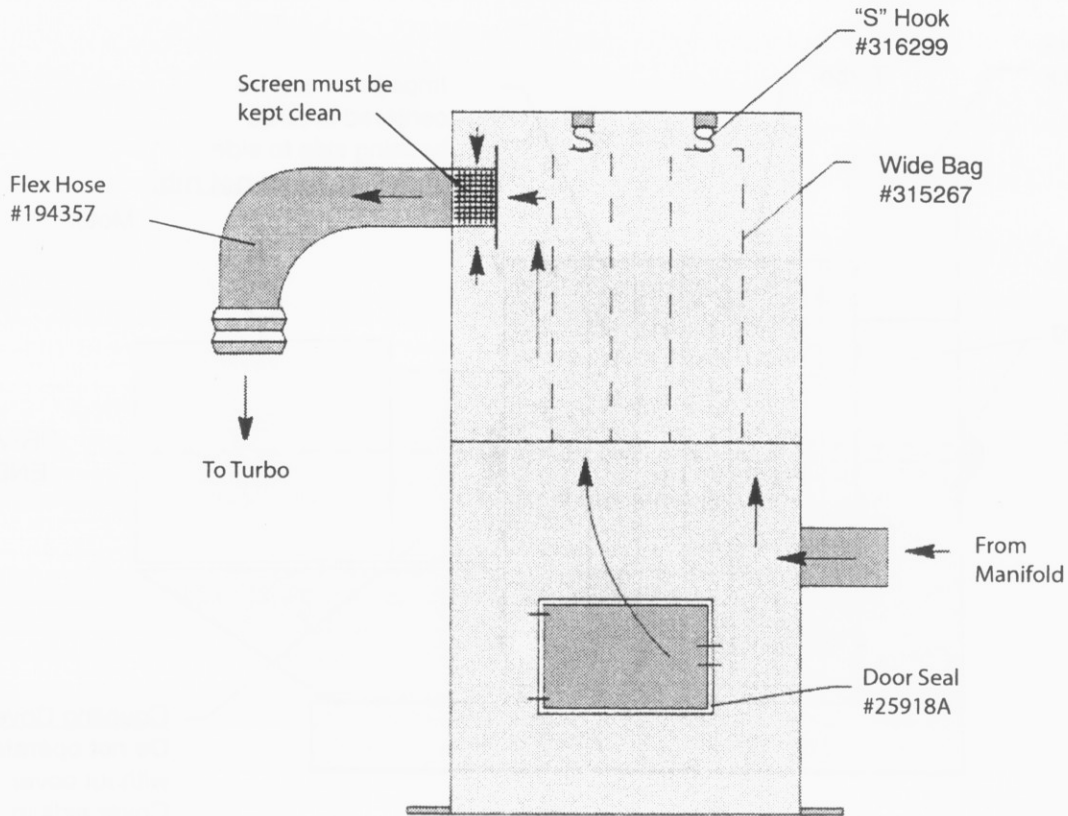

1. Mount turbo housing on rubber pads. For best results, use at least 1/2" thick pads.
2. Vacuum manifolds must drop in size every 15'.

Example:

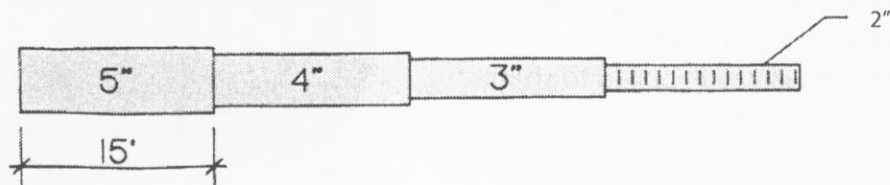

3. Shake vacuum bags every 40 hours of use.
4. Replace vacuum bags every 4 months.

VACUUM TURBO PRODUCER ADJUSTMENTS

5 Hp – 10 Hp – 15 Hp – 20 Hp

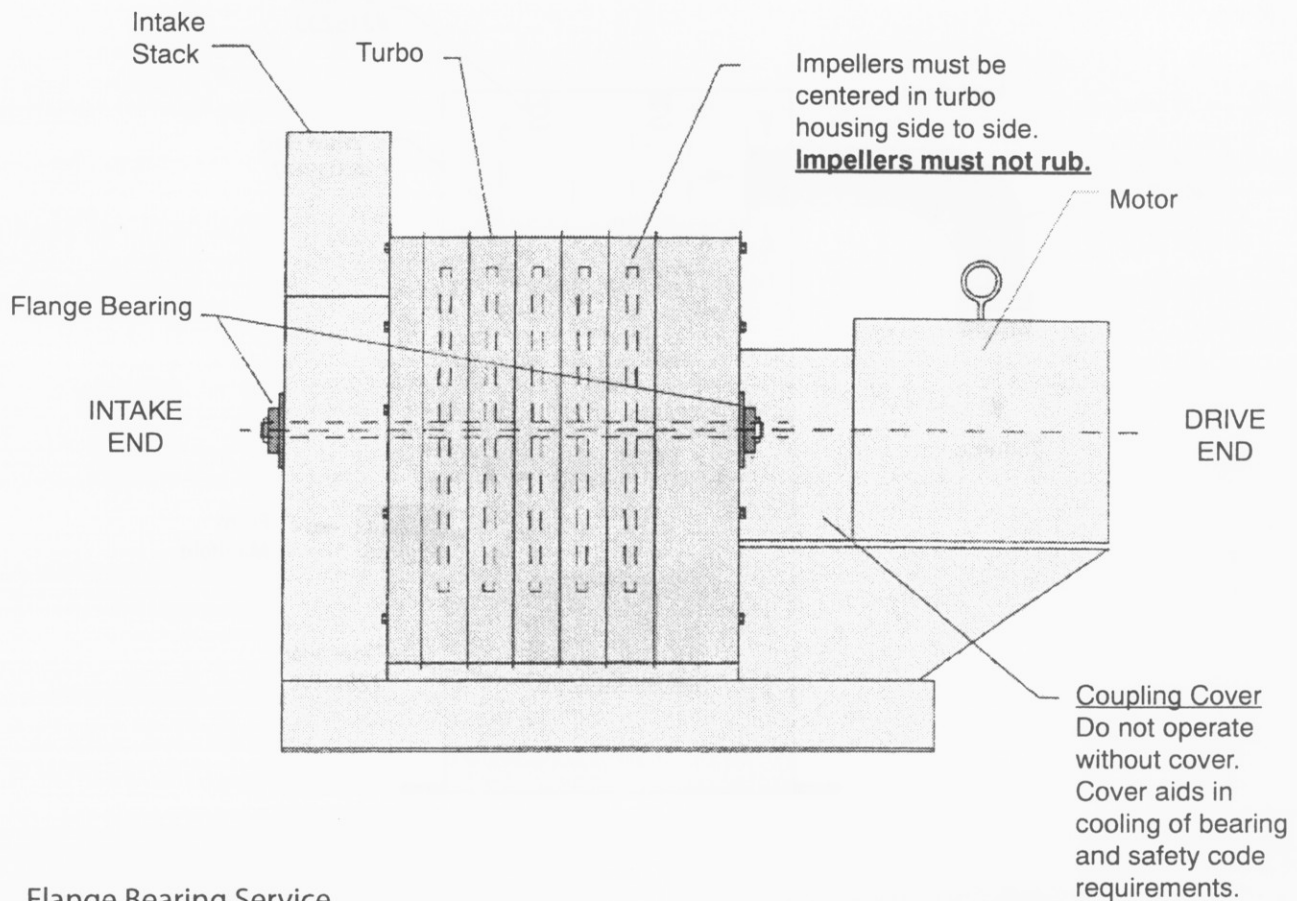

Flange Bearing Service

1. Remove one flange bearing at a time
2. Replace with new bearing (same position)
3. Bearing on intake end of turbo uses only one set screw. Remove and reuse special drive screw from old bearing locating drive screw in slot in shaft.
4. Note: Bearing will fail if locked to shaft and shaft could bend.
5. Bearing on driver end must be locked on shaft with the use of both set screws.

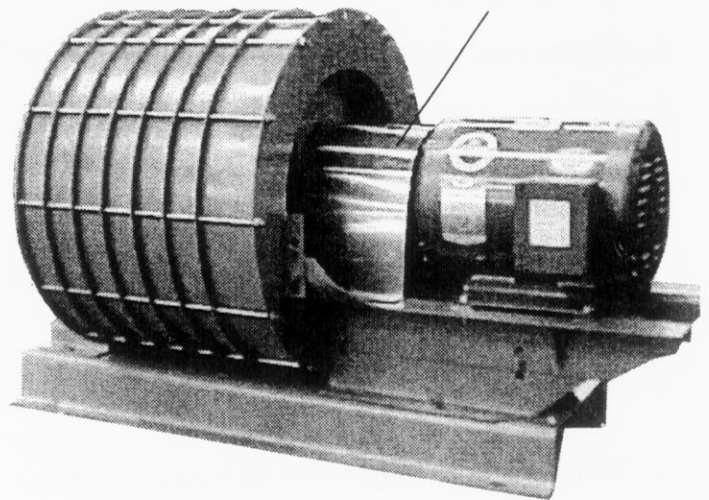

ADJUSTMENTS OF INNER TURBO ASSEMBLY IMPELLERS & SHAFT

1. Adjustment must be made with all set screws loose.
2. After bearings have been replaced, shaft should turn freely and slide end to end approx. $5/8$ "
3. Slide turbo shaft all the way to one end. Then slide shaft back approx. $5/16$ " of an inch, and lock set screws only on the drive end of the shaft (Motor end).
4. Before start up, place ear over intake stack and listen for any rubbing of impeller on inside of turbo housing while turning shaft by hand only.
DO NOT ATTEMPT THIS WHILE MOTOR IS RUNNING

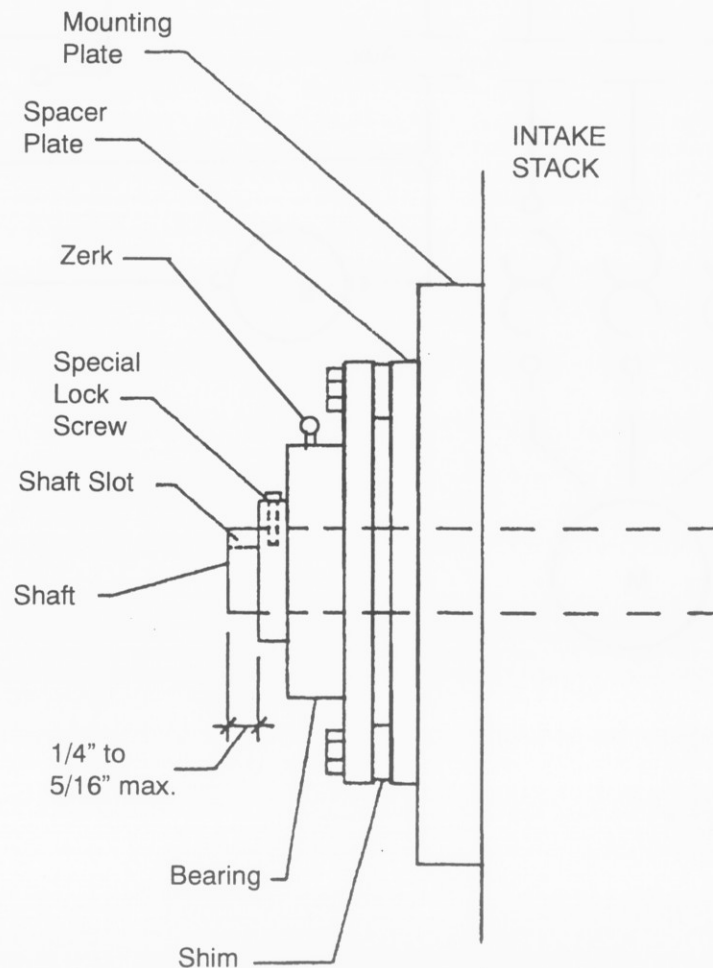

MOTOR CONTROL DIAGRAM

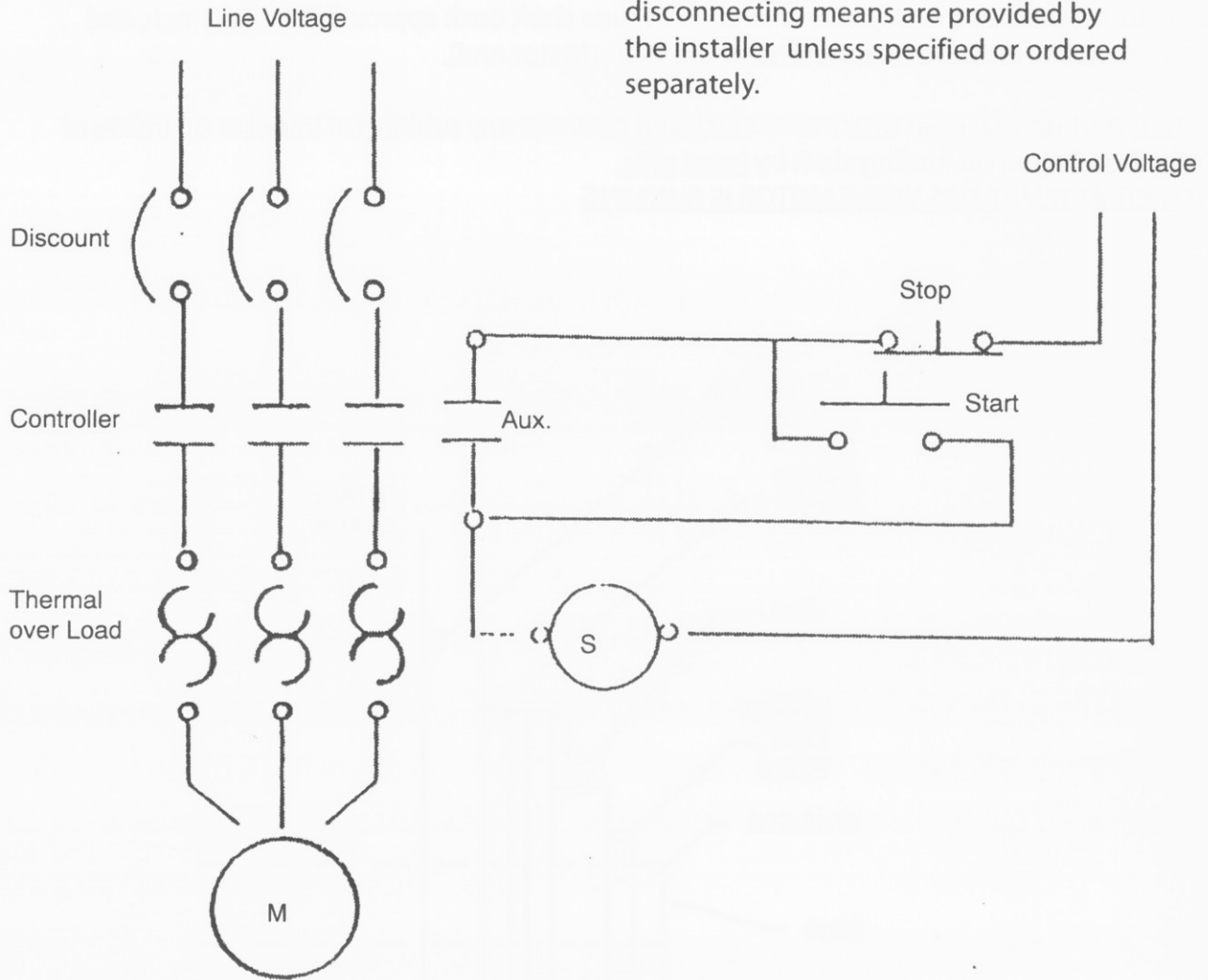

Note: Controller, push button station and disconnecting means are provided by the installer unless specified or ordered separately.

NATIONAL ELECTRICAL CODE
ARTICLE 430 - MOTOR CIRCUITS, CONTROLLERS

Disconnecting Means

430-101. General. Part H is intended to require disconnecting means capable of disconnecting motors and controllers from the circuit
(FPN No.1): See Diagram 430-1.
(FPN No.2): See Section 110-22 for identification of disconnecting means.

430-102. Location.

- (a) Controller. A disconnecting means shall be located in sight from the controller location.
- (b) Motor. A disconnecting means shall be located in sight from the motor location and the driven machinery location.

Exception: Where the disconnecting means provided in accordance with Section 430-102 (a) is capable of being locked in the open position.

430-109.Type. The disconnecting means shall be a motor-circuit switch rated in horsepower, a circuit breaker, or a molded case switch (non-automatic circuit interrupter).

Exception No. 2: On AC circuits, general use snap switches suitable only for use on AC (not general use AC-DC snap switches) shall be permitted to disconnect a motor rated 2 horsepower or less and 300 volts or less having a full load current rating not more than 80 percent of the ampere rating of the switch.

Vacuum Turbo Producer

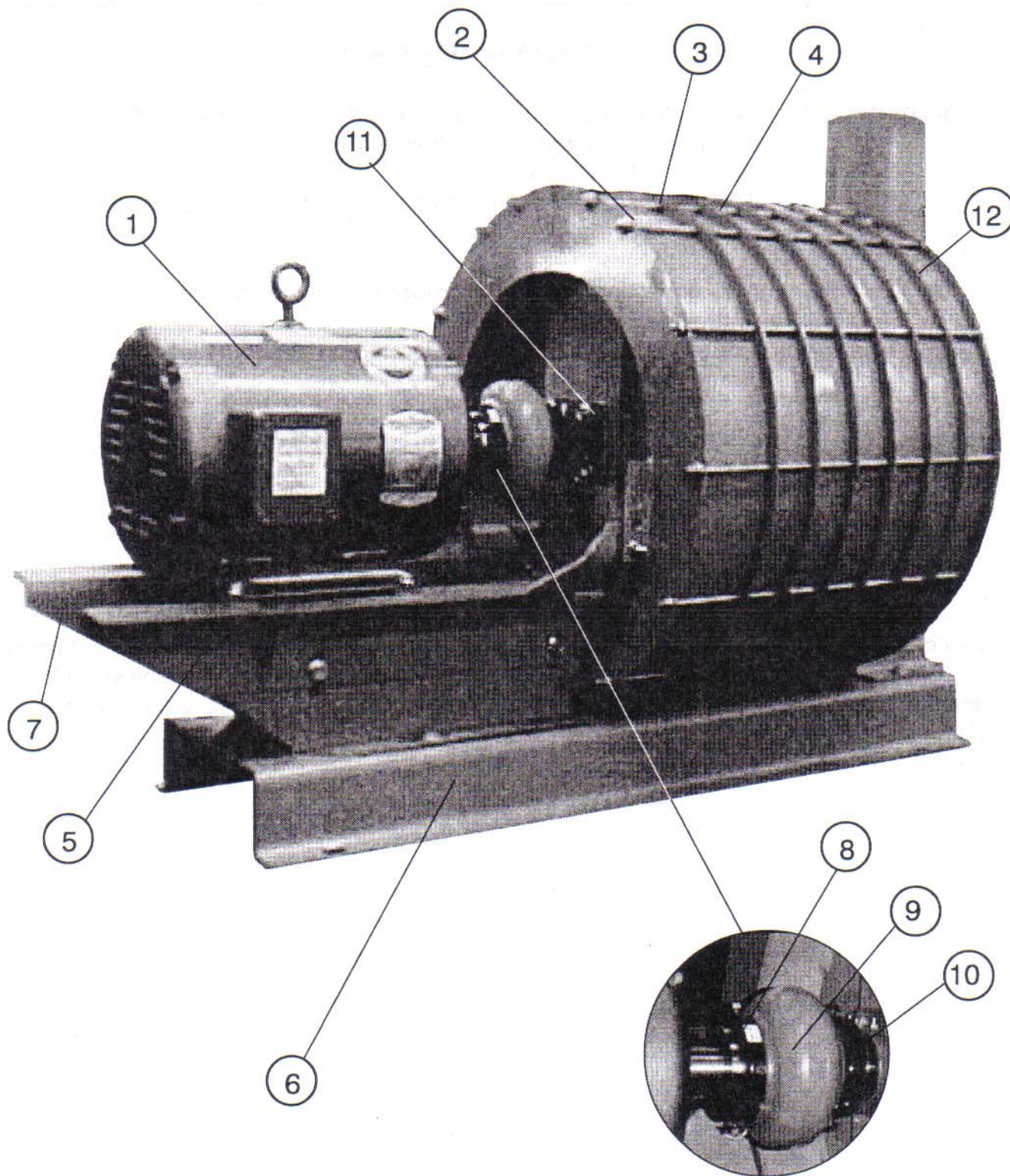

VACUUM TURBO PARTS BREAK DOWN – 15 HP

<u>Item</u>	<u>Parts</u>	<u>Item Description</u>	<u>Quantity</u>
1	066233	Motor	1
2	365287	5/16" flanged N.C. Lock Nut	28
3	249896	5/16" N.C. S/S TIE rod (15 Hp Turbo Only)	14
4	175042	Diffuser Plate	6
5	268243	R.H. Motor Support	1
6	764613	Sub-base	1
7	268250	L.H. Motor Support	1
8	365187	OMEGA 1-3/8 coupling (motor end) (15 Hp Only)	1
9	365189	OMEGA coupling element E5 (15 Hp Only)	1
10	365185	OMEGA 1" coupling (impeller end) (15 Hp Only)	1
11	010330	4 bolt 1" Flange Bearing - High speed	2
12	152736	Spacer Ring	6

VACUUM TURBO IMPELLER ASSEMBLY

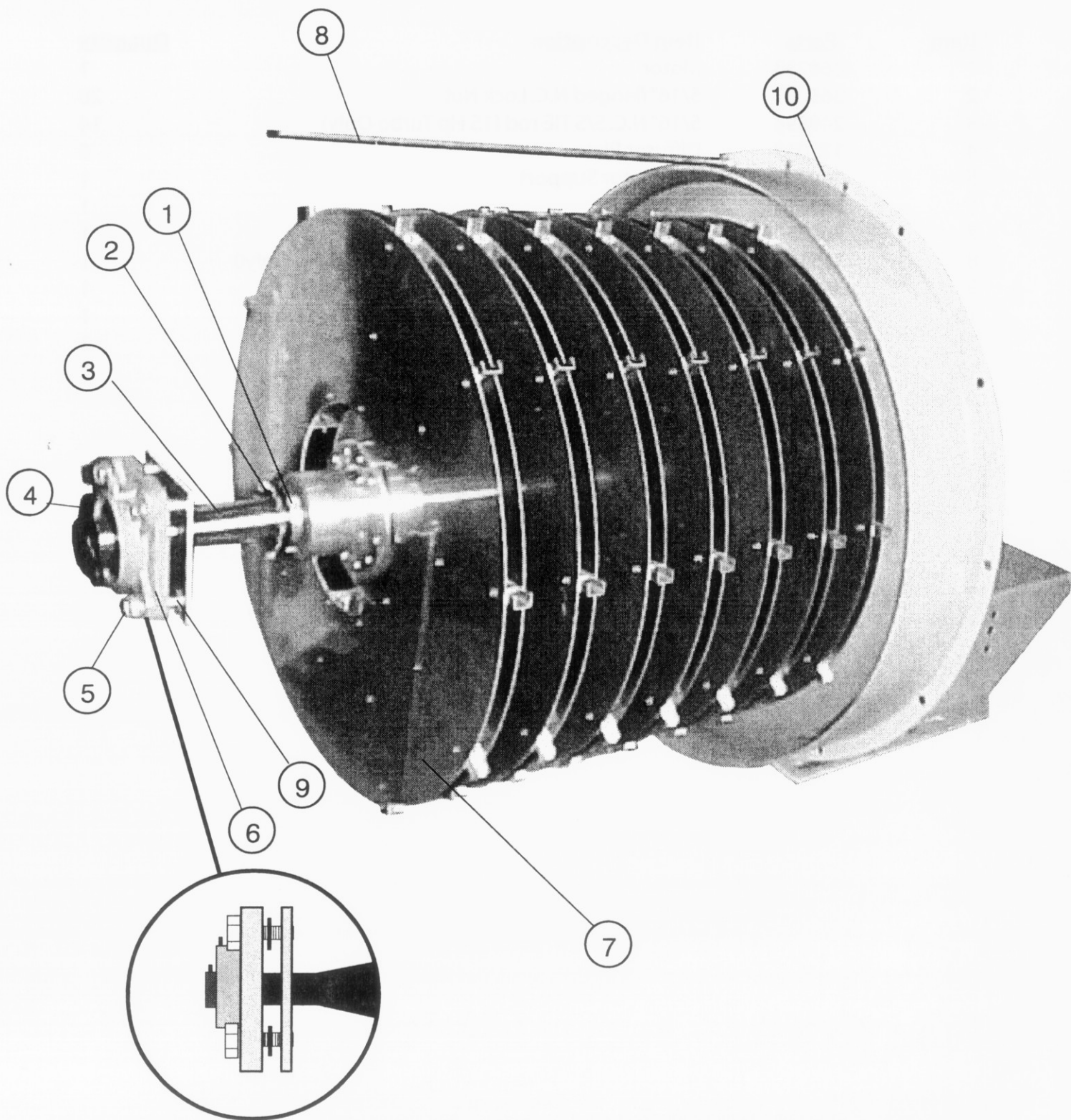

VACUUM TURBO IMPELLER ASSEMBLY – PARTS BREAK DOWN

<u>Item</u>	<u>Parts</u>	<u>Item Description</u>	<u>Quantity</u>
1	196253	Lock Nut	1
2	196246	Lock Washer	1
3	175059	Vacuum Impeller Shaft	1
4	017608	3/8 x 1-1/4" N.F. Cap Screw	1
5	017319	3/8" x 2 N.F. Cap screw	1
6	010330	1" 4 Bolt Flange Bearings	2
7	175174	Vacuum Impeller 1-3/8' bore	7
8	249826	Tie Bolt (15 Hp Only)	14
9	291912	Spacer Plate/Seal	1
10	268938	Motor Support Weldment	1

Vacuum Manifold

Operating Space Requirements

Suggested 2, 4 & 6 Hose Drop Layouts

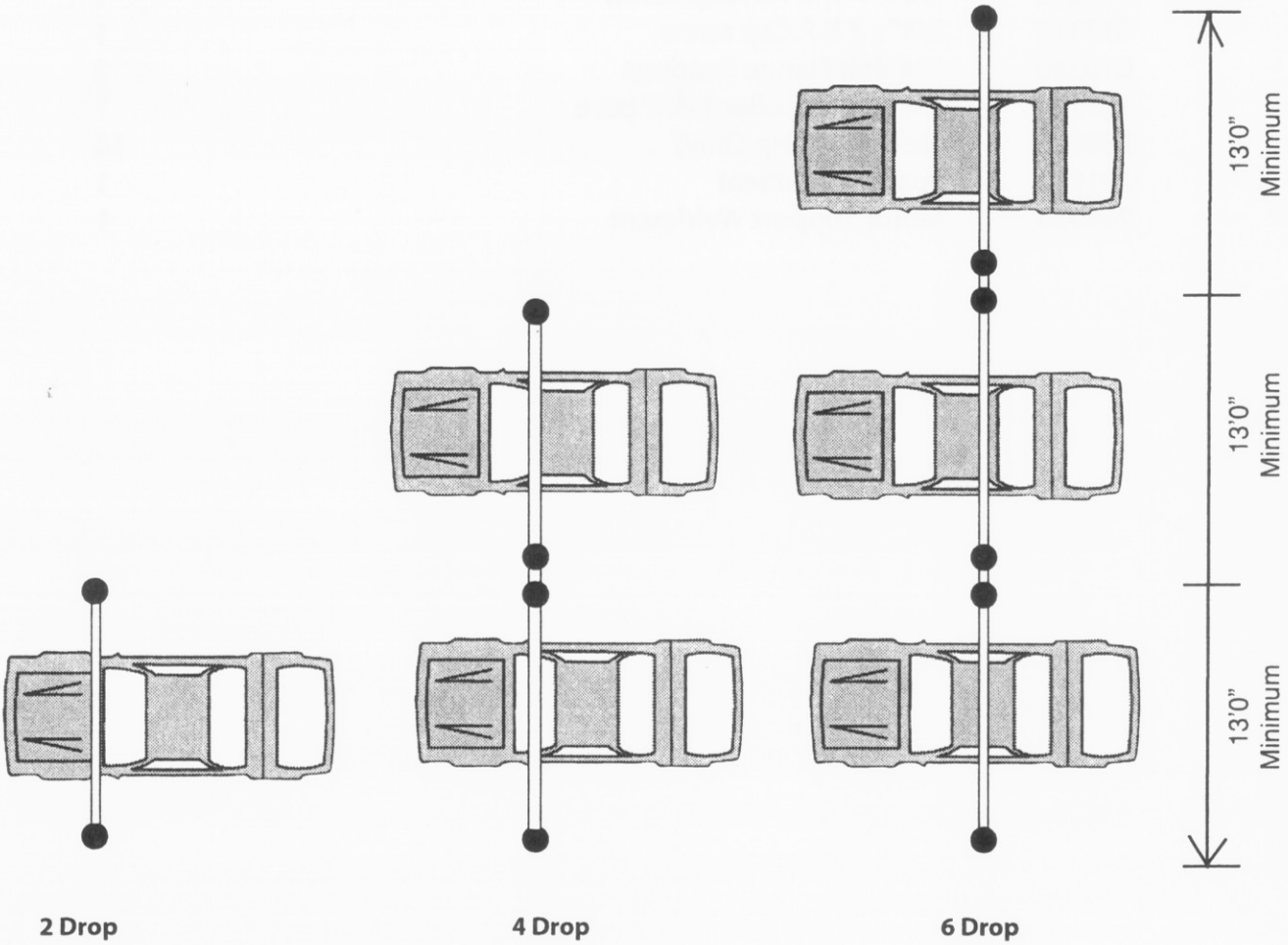

VACUUM MANIFOLD ACCESSORIES

Post or
Wall Mount
#718205

Vacuum Tool
#323485

Cuff
#032805

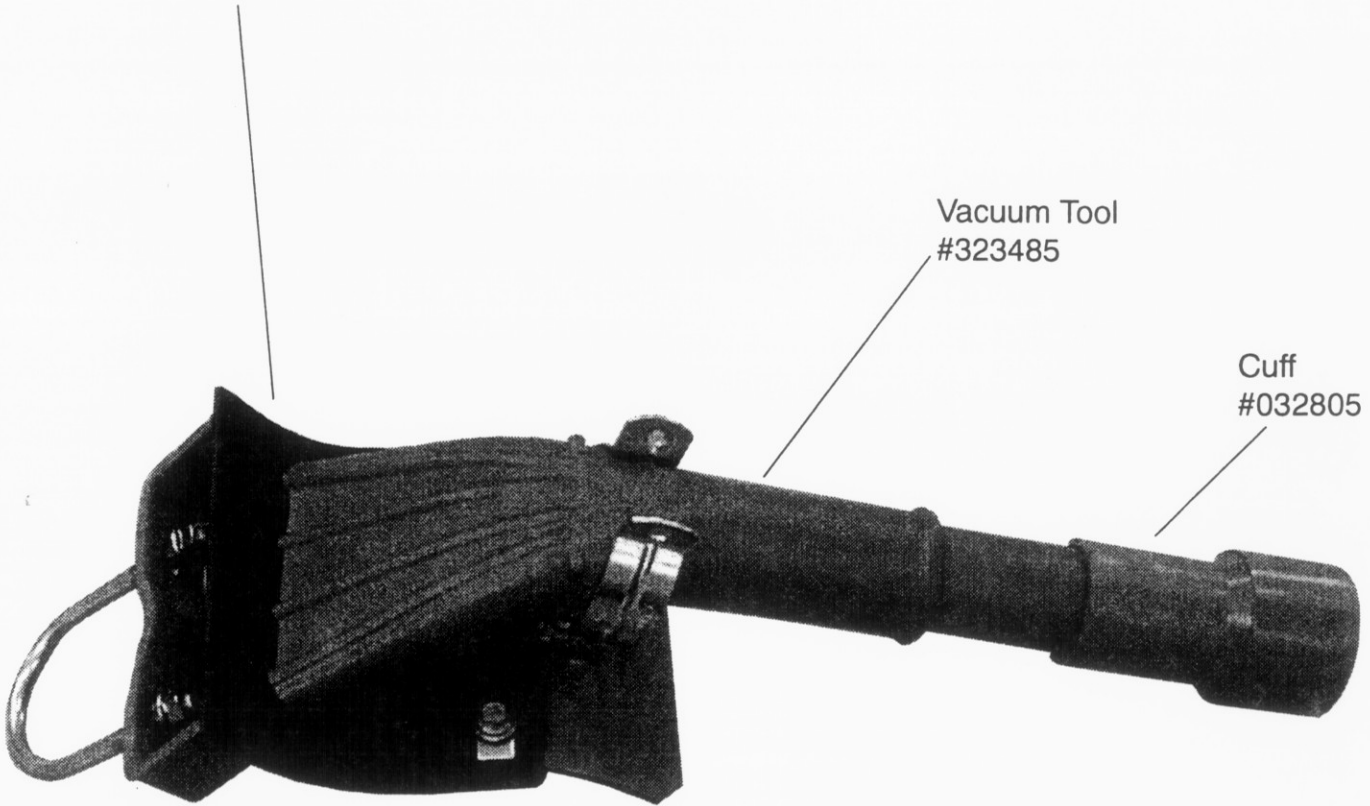

Vacuum Hose
#032821

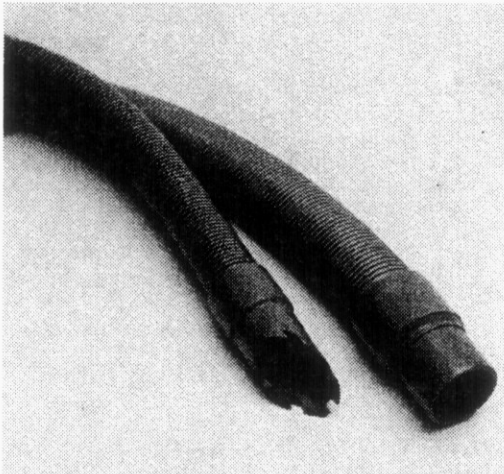

Vacuum Cuff
#032805

