



93050 & 94050 Shampoo Vac

Installation/Operations Manual



AN O'HANRAHAN COLEMAN COMPANY

5842 W 34th St • Houston, TX 77092

1.800.999.9878 1.713.683.9878

www.colemanhanna.com



Find us on Facebook:
[/ColemanHannaCarwash](https://www.facebook.com/ColemanHannaCarwash)



Table of Contents

INSTALLATION PROCESS	3
THEORY OF OPERATION	4
MAINTENANCE.....	5
SET UP	6
PROGRAMMING	7
IN-BAY.....	7
VAC.....	8
FRAGRANCE/VAC.....	8
SHAMPOOER AND SHAMPOO/VAC	9
GINSAN WIRING INSTRUCTIONS FOR TIMERS	10
TROUBLESHOOTING	15
93050/94050 PARTS LIST.....	18
93050/94050 PARTS BREAKDOWN.....	21

INSTALLATION PROCESS

- 1) Uncrate the vacuum and inspect for damage. Report all damage to freight lines.
- 2) Remove stainless steel shroud from under meter to expose 110V cord. Unbolt vacuum from wooden crate (save rubber washers).
- 3) Set vacuum cleaner on cardboard, and make a template or pattern by cutting out cardboard in shape of vacuum cleaner.
- 4) Take template and set on vacuum base, and mark holes for bolts.
- 5) Drill holes in concrete using a 1/2" drill bit. Blow out all concrete dust from holes.
- 6) Set vacuum cleaner over holes, and hammer in Anchor Bolts. Use 1/2" x 5 1/2" for 93050 Oval Vacuums and 1/2" x 3 3/4" for 94000 Round Vacuums. Make sure you install rubber washer between metal washer and vacuum canister to provide an airtight seal.
- 7) Plug vacuum in to the cord under the shroud. Install stainless steel shroud back in place.
- 8) Unscrew fill cap, located on top of shampooer cabinet. Add 5 gallons of water, then add 1 quart of shampoo concentrate.
- 9) Open up the Shampooer/Vacuum cabinet, and you will see a sight tube. This will show you how much liquid is in the tank.
- 10) Now, turn on the power to the vacuum cleaner, and install a sample coin in the Sensortron
- 11) Refer to Price and Time Setting Sheet to properly set price and time on timer. Unit is preset to price on decals and normal time.
- 12) Drop coins into coin acceptor until the price for the shampooer is reached. The vacuum will turn on, at first, then press shampoo button to select shampooer. The air compressor and shampoo pump will come on. Now press the button on the brush handle to dispense foam out of the brush head. You can adjust the amount of foam by turning the black knob on the metering valve, located inside the cabinet
- 13) Drop coins into coin acceptor and select vacuum. Check vacuum for proper suction, and install vacuum hose.

THEORY OF OPERATION

- 1) Coins are deposited into coin acceptor. Coin acceptor sends out a 24V pulse to the timer.
- 2) When the price of the vacuum is reached, the horn will beep rapidly for one second. At the time, you can continue to insert coins for the shampooer, or select vacuum by pressing the vacuum button.
- 3) When the vacuum button is pressed, the timer turns on the 24V Mercury Relay.
- 4) The Mercury Relay sends power to the vacuum motors.
- 5) The vacuum motors start to run, which draws air through the filter bags, and through the vacuum hose.
- 6) If additional coins are deposited, and vacuum has not been selected, then the vacuum will turn on when the price of the shampooer is reached. The vacuum turns on first to allow people to vacuum dirt out of their carpets. The shampooer can be selected by pressing the shampoo button.
- 7) When the shampoo button is pressed, a signal from the switch goes into the timer. The timer turns on the air compressor relay, air compressor solenoid and the carpet shampoo pump. Air from the air compressor comes out of the brush continuously when the air compressor is on. The liquid only comes out of the brush when the solenoid opens. The two products (air and shampoo) are carried in separate lines to the brush, where they mix in a small foam generator. You can regulate the liquid by adjusting the black knob on the liquid solenoid.

FREEZE PREVENTION SYSTEM

- 1) When the thermostat senses 40o or below, the computer will turn on the air compressor to blow out all moisture in the lines and brush. The air compressor and air solenoid will come on and turn off during a 15 minute cycle to insure proper drying of the lines. The air compressor will blow out the liquid line for four minutes; blow out the air line for 30 seconds, then shut down for 60 seconds, allowing any moisture to accumulate, before repeating the cycle again. The cycle can be programmed into the timer, please refer to timer programming instructions.

If you should turn off power during this 15-minute cycle, the cycle will start over again. The 15-minute blow-out cycle will start at any time the temperature falls below 40o, or when a customer finishes using the shampooer. The shampooer can be used when the 15 minute blow-out cycle is in use. If a customer starts using the shampooer while it is in purge cycle, the computer will stop blowing out, and wait until the customer is finished to start a new blow-out cycle.

MAINTENANCE

<i>Weekly</i>	<i>Every Six Months</i>
1) Clean out plastic dirt canister.	1) Remove vacuum dome and wash thoroughly.
2) Clean vacuum bags with brush.	2) Clean fluorescent lamps with damp towel.
3) Clean stainless steel door, and check gasket for leaks.	3) Check brushes in vacuum motor for wear, and replace as needed.
4) Wash vacuum hose inside and out.	4) Wash filter bags.
5) Wipe down outside of vacuum canister with damp cloth.	5) Wash out bottom dirt canister and dirt funnel.

SHAMPOO VAC PUMP NOTICE

PLEASE NOTE: Make sure when you push the hose onto the pump that you support the opposite side of the pump with your hand. If not, this will bend the shaft on the pump and cause it to leak.

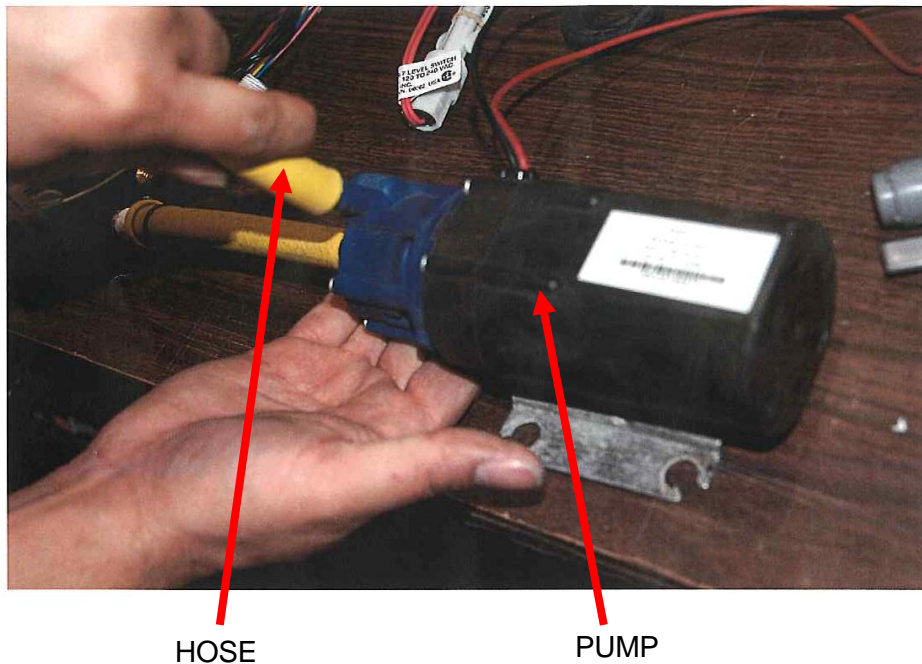

SET UP

I have a vacuum/shampooer machine that requires \$1.00 to start the vacuum, and \$2.50 to start the shampooer. The vacuum cycle lasts for a period of four minutes, while the shampooer cycle lasts for seven minutes. At the one-minute mark, I want to alert my customer, with five (5) beeps, that time is about to run out. A customer depositing additional coins while using the vacuum will receive one minute of time for each coin. A customer depositing additional coins while using the shampooer machine will receive forty-two seconds of time for each coin. I have chosen 3459 as my Personal Identification Number (PIN). I know that it takes me about three minutes to test my vacuum/shampooer machine. I want my freeze-protection system to be set up for four blow-out cycles, each four minutes long, with a two minute period between cycles. *The following is how I would set up my timer.*

Menu Entry	Description
A:04	Coins Required to Turn on Vacuum
B :00	Seconds Vacuum Cycle will Run
C4:00	Minutes Vacuum Cycle will Run
D :05	Number of Times Warning Horn will Sound.
H1:00	Amount of Time Earned by Depositing Additional Coins
A:10	Coins Required to Turn on Shampooer Machine
B:00	Seconds Shampooer Cycle will Run
C7:00	Minutes Shampooer Cycle will Run
D:05	Number of Times Warning Horn will Sound
H:42	Amount of Time Earned by Depositing Additional Coins
3EEE 34EE 345E 3459	Personal Identification Number (PIN#)
F3:00	Time the Test Function Runs for.
A:04	Number of blow-out cycles
B4:00	Length of blow-out cycles
C2:00	Length of time between blow-out cycles.

My timer is now set up and ready for operation.

1034R TIMER INSTALLATION

In order to avoid any confusion, the following is a pin out of the 1034R Timer:

1:	Not Used	
2:	Quarter Input	Orange/Black
3:	Horn (-)	Green/Black
4:	Horn (+)	Red/Black
5:	Safety Ground	Lime
6:	24 V Timed Output to Switch	Blue/Black
7.	Token Input	Red/Yellow
8.	Not Used	
9:	24V Common	Green
10:	24V Hot	Orange

PROGRAMMING INSTRUCTIONS

	Bay	Vac	Frag	Sham	
Unit Type	X	X	X	X	Bay (Bay Timer), Vac (Vacuum Timer), Frag (Fragrance Unit-Pole Mount/Stand-Alone Unit), Sham (Shampoo Unit-Pole Mount/Stand-Alone Unit), Fvac (Combo Fragrance/Vacuum Unit), Svac (Combo Shampoo/Vacuum Unit),
Nationality	X	X	X	X	Domestic, International
T	X	X	X	X	Token Value in Number of Quarters
A	X	X	X	X	Base Cost
B	X	X	X	X	Base Time
C	X	X	X	X	Bonus Time
Switched			X	X	Switched, Non Switched
S			X	X	Switch Time
D			X	X	Secondary Base Cost
E			X	X	Secondary Base Time
F			X	X	Secondary Bonus Time
H	X	X	X	X	Number of Horn Beeps at 60 Seconds
I				X	Number of Blow Out Cycles
J				X	Length of Blow Out
K				X	Time Between Blow Out
W	X	X	X	X	Wash Down Time (Bay) or Vac Run Time (Vacuum)
User Password	X	X	X	X	4 Digit Password
Supervisor Password	X	X	X	X	4 Digit Password

IN-BAY PROGRAMMING

- Depress Mode Button until the following words appear: BAY, VAC, FRAG, SHAM, FVAC, SVAC. Use "SET" button to select "BAY" for desired function programming.
 - If you intend to use the timer in a bay – press the mode again
 - The word DOM (Domestic-US) or INTR (International) – Depress "Set" button to select nationality.
 - Press Mode again "T" will appear allowing you to program "Token" setting.
 - If you are using a separate coin acceptor for tokens only – use set button to program token value.
 - If you are not using a separate coin acceptor for tokens disregard this setting.
- Depress mode again "A" will appear – allowing you to program "Turn-On Price" (i.e. \$1.00 to start) using set button each time it is pressed and released it advances \$0.25 up to \$5.00 for turn-on.
- Depress mode again "B" will appear allowing you to program "Time" (i.e. Base time 4:00 minutes) Using set button program time starting with minutes. When total minutes are set, use mode button to advance to seconds :00. Press mode button to advance to next digit :00
- Press mode again "C" appears allowing you to program bonus time or time received for additional quarters. A \$1.00 for 4:00 minutes additional quarter equal 1:00 minute – using mode will advance 1 digit at a time.
- Press mode again "H" allowing you to program horn setting. Use set button to advance one # at a time. Ten is a good number for this.
- Depress mode – "W" will appear allowing you to program "Wash Down Time" when using remote. Use mode to advance 1 digit at a time. *If not using Commander Remote C-1000 disregard this setting.*

Scrub-N-Vac/Combo Carpet Shampooer Installation/Operation Manual

- Program User Password. Program "PIN #" with Set Button move to next digit with mode button.
- Program Supervisor Password – program "Supervisor Password" with Set Button – move to next digit with mode button.

Timer is now programmed for In-Bay use.

VAC PROGRAMMING

7. Depress Mode Button until the following words appear: BAY, VAC, FRAG, SHAM, FVAC, SVAC. Use "SET" button to select "VAC" for desired function programming.
8. If you intend to use the timer in a VAC – press the mode again
 - The word DOM (Domestic-US) or INTR (International) – Depress "Set" button to select nationality.
 - Press Mode again "T" will appear allowing you to program "Token" setting.
 - If you are using a separate coin acceptor for tokens – use set button to program token value.
 - If you are not using a separate coin acceptor for tokens, disregard this setting.
9. Depress mode again "A" will appear – allowing you to program "Turn-On Price" (i.e. \$1.00 to start) using set button each time it is pressed and released it advances \$0.25 up to \$5.00 for turn-on.
10. Depress mode again "B" will appear allowing you to program "Time" (i.e. Base time 4:00 minutes) Using set button program time starting with minutes. When total minutes are set, use mode button to advance to seconds :00. Press mode button to advance to next digit :00
11. Press mode again "C" appears allowing you to program bonus time or time received for additional quarters. A \$1.00 for 4:00 minutes additional quarter equal 1:00 minute – using mode will advance 1 digit at a time.
12. Press mode again "H" allowing you to program horn setting. Use set button to advance one # at a time. Ten is a good number for this.
13. Depress mode – "W" will appear allowing you to program "VAC Run Time" when using remote.
14. Use mode to advance 1 digit at a time. *If not using Commander Remote C-1000 disregard this setting.*
 - Program User Password. Program "PIN #" with Set Button move to next digit with mode button.
 - Program Supervisor Password – program "Supervisor Password" with Set Button – move to next digit with mode button.

Timer is now programmed for vacuum use.

FRAGRANCE and FRAGRANCE/VAC PROGRAMMING

15. Depress Mode Button until one of the following words appear: FRAG, FVAC, Use "SET" button to select desired function for programming.
16. Press Mode again - the word DOM (Domestic-US) or INTR (International) – Depress "Set" button to select Nationality.
17. Press Mode again "T" will appear allowing you to program "Token" setting.
18. If you are using a separate coin acceptor for tokens – use set button to program token value.
19. If you are not using tokens – disregard this setting.
20. Depress mode again "A" will appear – allowing you to program "Turn-On Price" (i.e. \$1.00 to start) using set button each time it is pressed and released it advances \$0.25 up to \$5.00 for turn-on.

Scrub-N-Vac/Combo Carpet Shampooer Installation/Operation Manual

21. Depress mode again “B” will appear allowing you to program “Time” (i.e. Base time 4:00 minutes) Using set button program time starting with minutes. When total minutes are set, use mode button to advance to seconds :00. Press mode button to advance to next digit :00
22. Press mode again “C” appears allowing you to program bonus time or time received for additional quarters. A \$1.00 for 4:00 minutes additional quarter equal 1:00 minute – using mode will advance 1 digit at a time.
23. Press mode again – the words “Switched” or “Non-Switched” will appear. Select “SET” to selected desired mode.
24. Press mode again “S” will appear allowing you to program switch time. “Switched/Non-Switched”. *Switched if you are using fragrance that cost less than vacuum and you select vacuum, the timer will require additional money be deposited and switched time is the time allowed to make additional deposit or timer reverts to fragrance and times out.* (i.e. time 30 seconds) Using set button program time starting with minutes. When total minutes are set, use mode button to advance to seconds :00. Press mode button to advance to next digit :00.

A \$1.00	D \$0.75
B 4:00	E 0:45
C 1:00	F 0:15

25. Depress mode again “D” will appear – allowing you to program “Secondary Base Cost” (i.e. \$1.00 to start) using set button each time it is pressed and released it advances \$0.25 up to \$5.00 for turn-on.
26. Press mode again “E” appears allowing you to program secondary base time or time received for additional quarters. A \$1.00 for 4:00 minutes additional quarter equal 1:00 minute – using mode will advance 1 digit at a time.
27. Press mode again “H” will appear allowing you to program horn setting. Use set button to advance one # at a time. Ten is a good number for this.
28. Depress mode – “W” will appear allowing you to program “Vac Run Time” when using remote. Use mode to advance 1 digit at a time. *If not using Commander Remote C-1000 disregard this setting.*
29. Program User Password. Program “PIN #” with Set Button move to next digit with mode button.
30. Program Supervisor Password – program “Supervisor Password” with Set Button – move to next digit with mode button.

Timer is now programmed for use in the fragrance or fragrance/vac unit.

SHAMPOOER and SHAMPOO/VAC PROGRAMMING

31. Depress Mode Button until one of the following words appear: SHAMP, SVAC, Use “SET” button to select desired function for programming.
32. Press mode again - the word DOM (Domestic-US) or INTR (International) – Depress “Set” button to select Nationality.
33. Press Mode again “T” will appear allowing you to program “Token” setting.
34. If you are using a separate coin acceptor for tokens – use set button to program token value.
35. If you are not using tokens – disregard this setting.
36. Depress mode again “A” will appear – allowing you to program “Turn-On Price” (i.e. \$1.00 to start) using set button each time it is pressed and released it advances \$0.25 up to \$5.00 for turn-on.
37. Depress mode again “B” will appear allowing you to program “Time” (i.e. Base time 4:00 minutes) Using set button program time starting with minutes. When total minutes are set, use mode button to advance to seconds :00. Press mode button to advance to next digit :00

Scrub-N-Vac/Combo Carpet Shampooer Installation/Operation Manual

38. Press mode again "C" appears allowing you to program bonus time or time received for additional quarters. A \$1.00 for 4:00 minutes additional quarter equal 1:00 minute – using mode will advance 1 digit at a time.
39. Press mode again – the words "Switched" or "Non-Switched" will appear. Select "SET" to selected desired mode.
40. Press mode again "S" will appear allowing you to program switch time. *"Switched/Non-Switched". Switched if you are using shampoo that cost less than vacuum and you select vacuum, the timer will require additional money be deposited and switched time is the time allowed to make additional deposit or timer reverts to shampoo and times out. (i.e. time 30 seconds) Using set button program time starting with minutes. When total minutes are set, use mode button to advance to seconds :00. Press mode button to advance to next digit :00.*

A	\$1.00	D	\$0.75
B	4:00	E	0:45
C	1:00	F	0:15

41. Depress mode again "D" will appear – allowing you to program "Secondary Base Cost" (i.e. \$1.00 to start) using set button each time it is pressed and released it advances \$0.25 up to \$5.00 for turn-on.
42. Press mode again "E" appears allowing you to program secondary base time or time received for additional quarters. A \$1.00 for 4:00 minutes additional quarter equal 1:00 minute – using mode will advance 1 digit at a time.
43. Press mode again "H" will appear allowing you to program horn setting. Use set button to advance one # at a time. Ten is a good number for this.
44. Press mode again "I" will appear allowing you to program number of Blow Out Cycles. Use set button to advance one # at a time. 4 is a good number for this.
45. Press mode again "J" will appear allowing you to program length of Blow Out. (i.e. time 4:00 minutes) Using set button program time starting with minutes. When total minutes are set, use mode button to advance to seconds :00. Press mode button to advance to next digit :00.
46. Press mode again "K" will appear allowing you to program time between Blow Out. (i.e. time 2:00 minutes) Using set button program time starting with minutes. When total minutes are set, use mode button to advance to seconds :00. Press mode button to advance to next digit :00.
47. Depress mode – "W" will appear allowing you to program "Run Time" when using remote. Use mode to advance 1 digit at a time. *If not using Commander Remote C-1000 disregard this setting.*
48. Program User Password. Program "PIN #" with Set Button move to next digit with mode button.
49. Program Supervisor Password – program "Supervisor Password" with Set Button – move to next digit with mode button.

Timer is now programmed for use in the shampooer or shampoo/vac unit.

TECHNICAL SHEET

800 - 446 - 7267

Sensortron™ & Multitron™ Hook-up to Various Timers

National Pride Timer

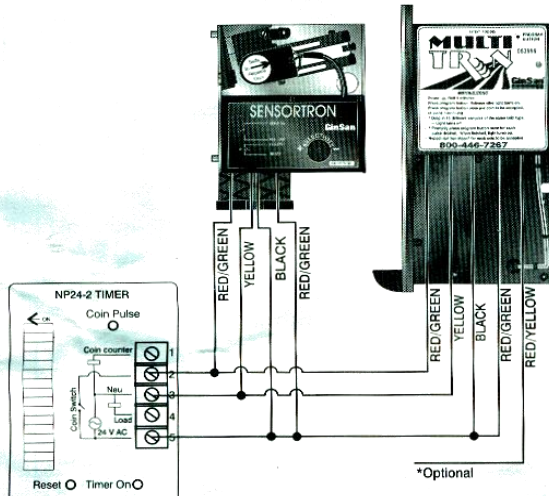

(*Optional RED/YELLOW wire for digital coin counters)

Paraplate Timer

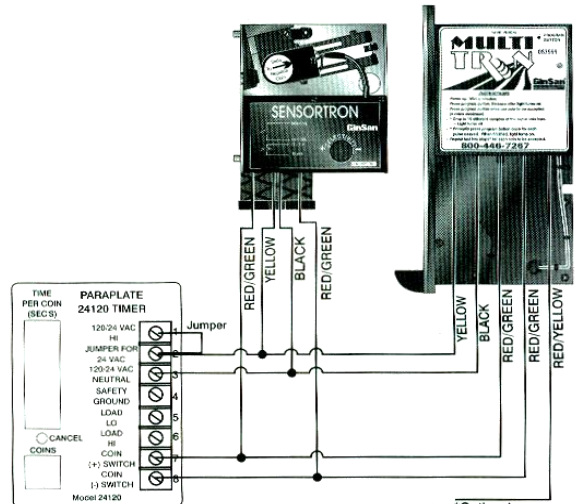

(*Optional RED/YELLOW wire for digital coin counters)

KELTNER TIMER 9-D

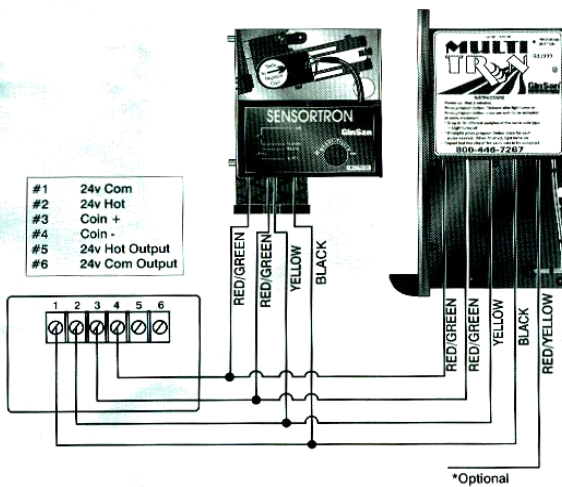

(*Optional RED/YELLOW wire for digital coin counters)

KELTNER TIMER LC-1 / RT-1

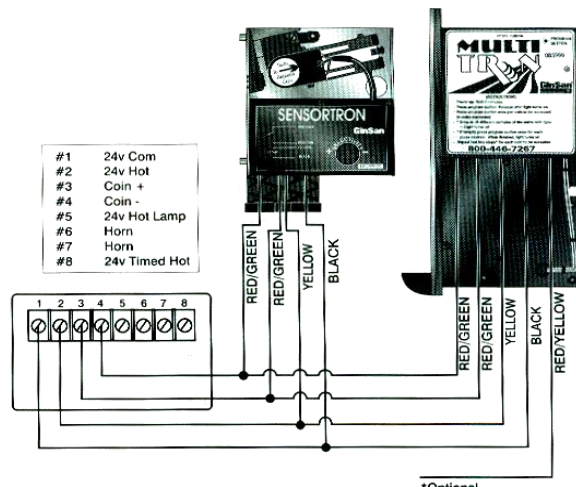

(*Optional RED/YELLOW wire for digital coin counters)

TECHNICAL SHEET

800 - 446 - 7267

Sensortron™ & Multitron™ Hook-up to Various Timers

D&S Timer DS203 Digital Display Timer

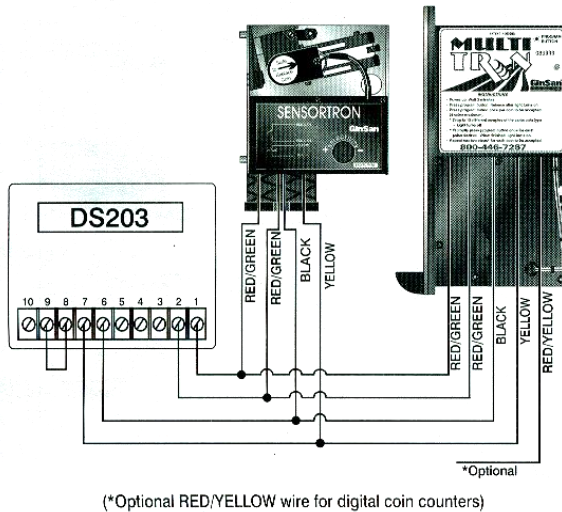

CT2000 Timer Jim Coleman

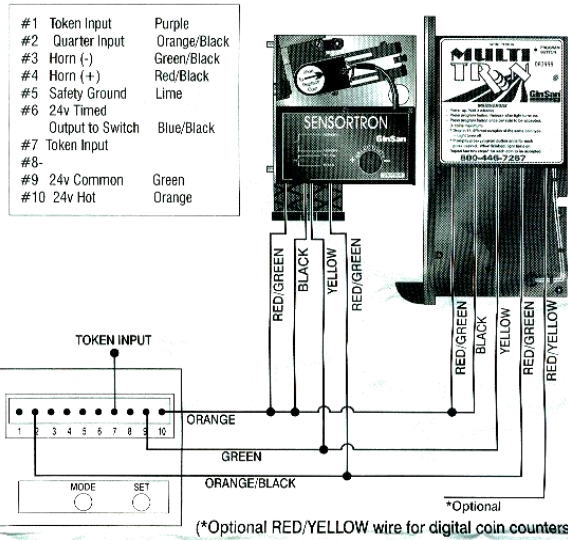

TIMERMASTER TM-5

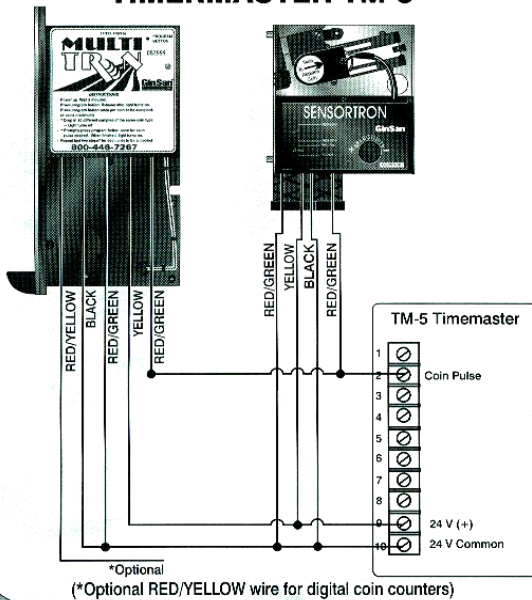

AVS Systems GP Timer

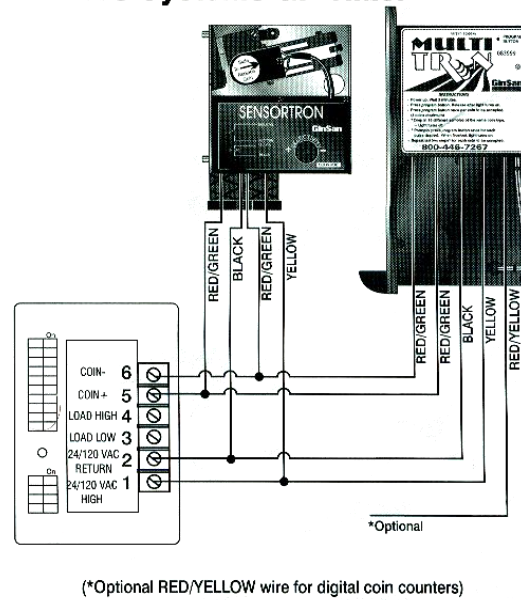

TECHNICAL SHEET

800 - 446 - 7267

Sensortron™ & Multitron™ Hook-up to Various Timers

MAGIK TIMER Model MT580

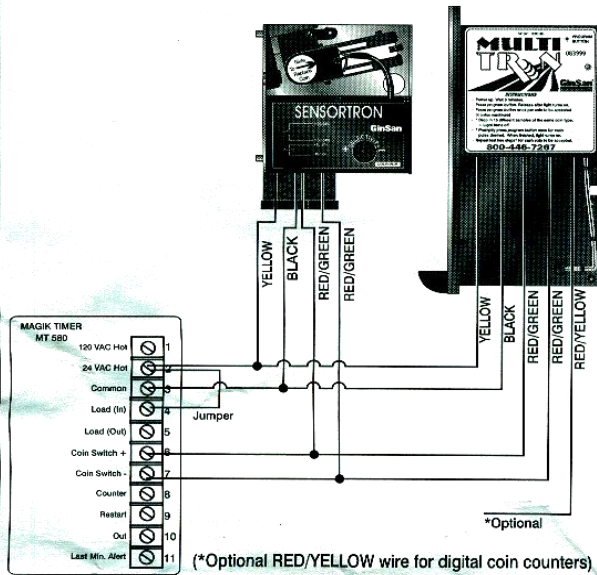

MAGIK TIMER MODEL MT 415

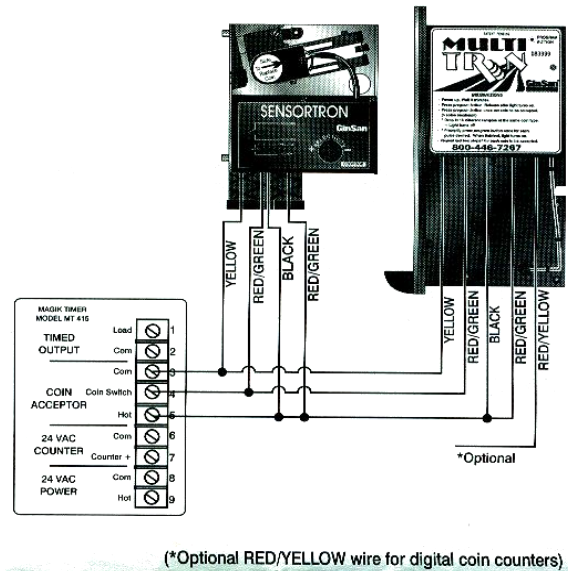

IMPORTANT
Wiring Instructions

IMPORTANT
Wiring Instructions

MultiTron™ Wiring Instructions For Various Timers
Note: Red/Green wires are interchangeable.
Red/Yellow wire can be used as a separate coin output.
See step #4 for details.

GinSan Timer (GS-9 110 Volt) to Universal GS-44

Black wire to Terminal #5
Yellow wire to Terminal #7
Red/Green wires to Terminal #4 & #5
Red/Yellow wire to Terminal #4

GinSan Timer (GS-11 110 Volt) to Universal GS-44

Black wire to Terminal #4
Yellow wire to Terminal #1
Red/Green wires to Terminal #3 & #4
Red/Yellow wire to Terminal #3

D & S Timer to Universal GS-44

Black wire to 24 Common(L2)
Yellow wire to 24 Hot(L1)
Red/Green wires to 24 Common(L2) & Coin Terminal
Red/Yellow wire to Coin Terminal

Paraplate Timer to Universal GS-44

Black wire to -Coin Switch
Yellow wire to Jumper for 24 V AC
Red/Green wires to +Coin Switch & -Coin Switch
Red/Yellow wire to + Coin Switch

Keltner Timer 24 Volt to Universal GS-44

Black wire to Terminal #2
Yellow wire to Terminal #1
Red/Green wires to Terminals to #2 & #4
Red/Yellow wire not used (Requires interface)

Parker Timer to Universal GS-44

Black wire to Terminal #1
Yellow wire to Terminal #3
Red/Green wires to Terminals #1 & #4
Red/Yellow wire to Terminal #4

Dixmor Digital Timer to Universal GS-44

Black wire to 24 V AC Common (IN)
Yellow wire to 24 V AC Hot (IN)
Red/Green wires to Coin Common & Coin Signal
Red/Yellow wire to Coin Signal

GinSan 3611 3 Mile Rd. N.W.
 Grand Rapids, MI 49544

1-800-446-7267 www.ginsan.com

TROUBLESHOOTING

In order to troubleshoot Coleman Hanna equipment it helps to have knowledge on how the equipment is supposed to operate properly. Please read the following carefully. In normal operation, the shampooer will have a green digital display showing \$.00 - this is your timer and should be lit at all times. The timer will receive inputs and send outputs for proper function. This display requires 24V to be lit at all times. The push button switches on the door and the Sensortron are also 24V hot. When coins are deposited into the Sensortron the timer receives a pulse from the Sensortron telling the timer one coin was deposited. Once the number of coins has been reached you can press the corresponding button sending a signal to the timer telling the timer to send the proper output to the correct relay starting that function. Refer to the wiring diagram (left hand corner) for wire and color controls output and input. (Also refer to "Theory of Operation" on page 2)

1. "NO DISPLAY - WILL NOT ACCEPT MONEY - NOTHING WORKS"

- Vac requires 110V to operate. Check to be sure that 110V are present. If voltage is not present check all breakers. If all is good - call an electrician.
- Check for 110V Power at Breaker inside Cabinet.
- If power is found, then check for 24V coming out of Transformer (Yellow/Blue wires)
- If you do not have 24V then the Transformer is bad.

2. "NO SUCTION"

THEORY: Vac Motors turn pulling air through bottom of motors creating a suction through filter bags and out hole for hose.

- Check for clogged hose - Remove hose - place hand over hole - is there suction now?
- If there is still no suction - check to be sure both motors are running. (Remember - when one motor runs the other motor will turn due to the passing of air).
- Check screen on bottom of motor for dust build up - if there is a build up - remove dust and replace motors.
- If you still do not get results - clean filter bags (dirty filter bags will not allow air to pass through them) leaving you with little or no suction. Also, dirt doors with bad gaskets do not make a good seal leaving you with little or no suction.

3. "NO LED DISPLAY"

THEORY: Timer needs 24V Hot.

- Check for 110V coming in to unit - if no voltage - check breakers.
- If voltage is present - check transformer (Blue-Hot / Yellow-Neutral).
- If no voltage is coming out of transformer - replace transformer.
- If 24V is coming out of transformer - replace timer.

4. SHAMPOOER WILL NOT START

THEORY: Shampooer has a low water cut-off to keep from burning pump out if the unit is out of liquid. The vacuum will start immediately not allowing a shampoo selection. Coins can still be deposited.

- Check level of shampoo - if low add 5 gallons water and 1 quart shampoo.
- If tank is full - replace float switch.

5. CARPET PUMP

THEORY: Pump runs entire time Shampooer is operating. The pump forces liquid through a 3/8" hose to the liquid solenoid through the solenoid to brush. If this pump is not running liquid will not get to the handle.

- If pump is not running check for 110V on Carpet Pump Relay (refer to Schematic). If 110V is present, replace pump.
- If 110V is not present - Swap relays.
- If no results, check for 24V to energize relay.
- If 24V is not present - contact factory.
- If pump is running - yet no liquid - Remove 3/8" hose from solenoid. Point hose outside of cabinet. Liquid will be coming out of hose due to gravity. Insert money to start pump. Pump should squirt a stream of water approximately 10'. If it is weak, replace seals or pump.

6. AIR COMPRESSOR

THEORY: When correct amount of coins have been deposited - air compressor will run the entire length of time. Air Compressor pushes air out through the solenoid down the 1/8" tube and out the brush. If the air compressor is not running you may have liquid but will not have a nice thick foam.

- Unplug compressor - insert proper number of coins. Check plug with voltmeter. 110V should be present. If not, check voltage at air compressor relay. If 110V is present - replace air compressor.
- If voltage is not going through relay - swap relays to test relay. If this does nothing - check for 24V to energize relay.

7. NO LIQUID AT BRUSH

THEORY: When correct amount of money is deposited - Shampooer begins to run. The air compressor and shampoo pump run at all times while shampooer is on. They do not run when vac is on. When button on shampoo handle is pressed 24V goes to opening the shampoo solenoid allowing product to pass through to the handle.

- If Carpet Pump (Blue/Black Pump) is not running check for 110V. With the correct amount of coins to start shampooer deposited, you can check for voltage on the shampoo pump relay. Refer to wiring schematic - If no voltage - contact factory. If 110V is present at the pump but pump is not running - replace pump.

Scrub-N-Vac/Combo Carpet Shampooer Installation/Operation Manual

- Does solenoid open when button is pressed? Remove 1/8" tube that goes to air solenoid. Hold facing outside cabinet. Press button - does fluid come out? If so, replace tube back in fitting. If not, check for 24V to solenoid. If 24V is present, turn power off - clean solenoid and re-check.
- If the above items are operating, remove brush on stainless steel housing - Cut 1/8" tubes from hose barbs. Press button on handle - if liquid comes out check barbs for a clog. Replace tubes and retry.

8. NO FOAM

THEORY: When button on handle is pressed, liquid goes through solenoid to brush mixing with air at brush creating foam.

- If no liquid is present - refer to "NO LIQUID" section above.
- Air Compressor must be running - if not, refer to "AIR COMPRESSOR" section above.
- If liquid is present at the brush but is not foamy, check to make sure air is coming from brush, put hand over brush without pushing button. If air is coming out - you will feel it.
- Add 1 quart of product to tank - do not add water.
- Remove 1/4" cap from foam generator. Take black foaming material out of generator. Note: If black mesh material is gone, product will not foam. DO NOT USE STEEL WOOL - ORDER FROM FACTORY. If mesh is present, remove, unfold, rinse, reinsert in generator, recheck.

9. "UNIT WILL NOT ACCEPT COINS"

THEORY: Sensortron needs 24V Hot to accept coins.

- Check for 24V using a voltmeter between yellow wire and black wire coming from Sensortron. If 24V is present, replace Sensortron.
- If no voltage check for 24V coming out of transformer (Yellow-Neutral / Blue-Hot).
- If no voltage, check for 110V coming into transformer (Black-Hot / White-Neutral).
- If voltage is found replace transformer.
- If no voltage check breaker on vac - if good check breaker in equipment room.

10. "VAC UNIT WILL NOT RUN"

THEORY: Timer receives signal from Sensortron and sends out a signal to mercury relay allowing 110V to pass through turning motors.

- Check for 110V on top of mercury relay.
- Check vac motors for voltage.
- If 110V is not present on top of mercury relay check for 110V coming into relay.
- If relay has 110V, check for 24V to energize relay.
- If 24V is not present check switch - if switch is good - call a service technician.

93050 & 94050 PARTS LIST

ITEM	PART #	DESCRIPTION
1	93100	SS Vacuum Body (1)
	94100	SS Vacuum Body (1)
2	93111	Poly Vacuum Dome Oval
	92111	Poly Vacuum Dome Round
3	37400	Vacuum Body Decal-White
	37410	Vacuum Body Decal-Blue
4	93115	Dome Anchor Bolt (6)
5	92116	Dirt Door W/ Hinge For Rnd Vac-1
	93120	Vacuum Dirt Door W/ Hinge
6	93125/93121	Dirt Door Gasket (2)
	92120	Dirt Door Gasket (1)
7	93130	Screw-Dirt Door Hinge (1)
	92132	Screw Dirt Door Hinge
8	93135	Dirt Door Latch
	92128	SS Dirt Door Latch (2)
10	93145	Vacuum Door Strike
	92136	Vacuum Dirt Door Strike
19	24384/24385	Cam Lock Assembly
22	37104	Price Decal
25	26022	Coin Return Cup (1)
27	93185	Coin Box Tray SS (1)
28	26243	Electronic Coin Acceptor (1)
29	24442	Abus Coin Box Lock (1)
30	93190	Coin Box Door (1)
31	93195	SS Shroud (1)
32	93200	Screw-Shroud (6)
36	93320	Motor Bracket (4)
37	93225	Screw-Motor Brackets (8)
39	66036	Vac Motor Filter Screens (2)
40	92156	Vac Motor Gasket
41	55116	Vacuum Motor 1.6 Hp 110V(2)
42	42000	Vacuum Dome Light Fixture
43	42004	Vacuum Dome Light Fixture Bulb
45	52100	1/8" Tubing
46	93240	Rubber Grommet (2)

93050 & 94050 PARTS LIST cont.

ITEM	PART #	DESCRIPTION
47	28064	PVC Handle
48	28050	SS Shampoo Housing
49	93245	Filter Bag (4)
50	93250	Sealing Washer (4)
51	93255	Wing Nut (4)
52	28070	22 Gauge Wire
53	92176	Power Cord (1)
54	37349/37344	Foam Decal
55	28044	Brush Only
56	92200	2" X 15' Vacuum Hose (1)
57	92214	2" X 2" Vacuum Swivel Cuff (1)
58	92229	Black Upholstery Tool (1)
59	28046	Shampoo Brush Screws
60	40023	Square D 25 Amp Circuit Breaker
62	60010	Durakool 24V Mercury Relay (1)
63	82062	24 V-120 V Transformer (1)
64	93260	Wiring Harness (1)
65	93265	Motor Power Cord (1)
66		Cabinet
67	24095	110V Heater
68	26025	Coin Chute
69	12002	Air Compressor
71	22196	1/8" Street Tee
73	93170	Door Gaskets
74	68120	Freeze Thermostat
75	40002	6 Pin Terminal Strip
80	64072	¼" 3-Way Solenoid - 24V
81	52120	10132 Adapter
82	51212	1/8" Barb Ftgs
83	64071	¼" 24V Liquidsol
84	40112-16	Small Relay Base
85	40112-13	Small Relay IPDT 24V
86	82017/82017-N	Count Down Timer 1034R / 1034S

93050 & 94050 PARTS LIST cont.

ITEM	PART #	DESCRIPTION
87	22002	3/8" MPT x 3/8" SAE Coupling
88	28040	12' x 3/8" Hose Assy
89	57106	Carpet Shampoo Pump
90		Hinge
93	46030	Air Hose
95	46014	Door
96	72050	Float Switch
97	28036	Shampoo Thermostat
98	24384/24385	Cam Lock Cam
102	42090	Green Light
103	72026	Push Button Switch
105	37450	Door Decal
107	24352	Cam Lock Mounting Nut
108	29348	Cam Lock Lock-Washer
109	24350	Cam Lock Nut
111	46024	Visual Tube Mounting Gasket
114	37462	Vacuum Decal
115	52169	12' x 3/8" Hose
117	52100	12' x 18" (x4) Hoses
118	42092	Red Light
119	28044	Shampoo Gasket

PARTS BREAKDOWN 1

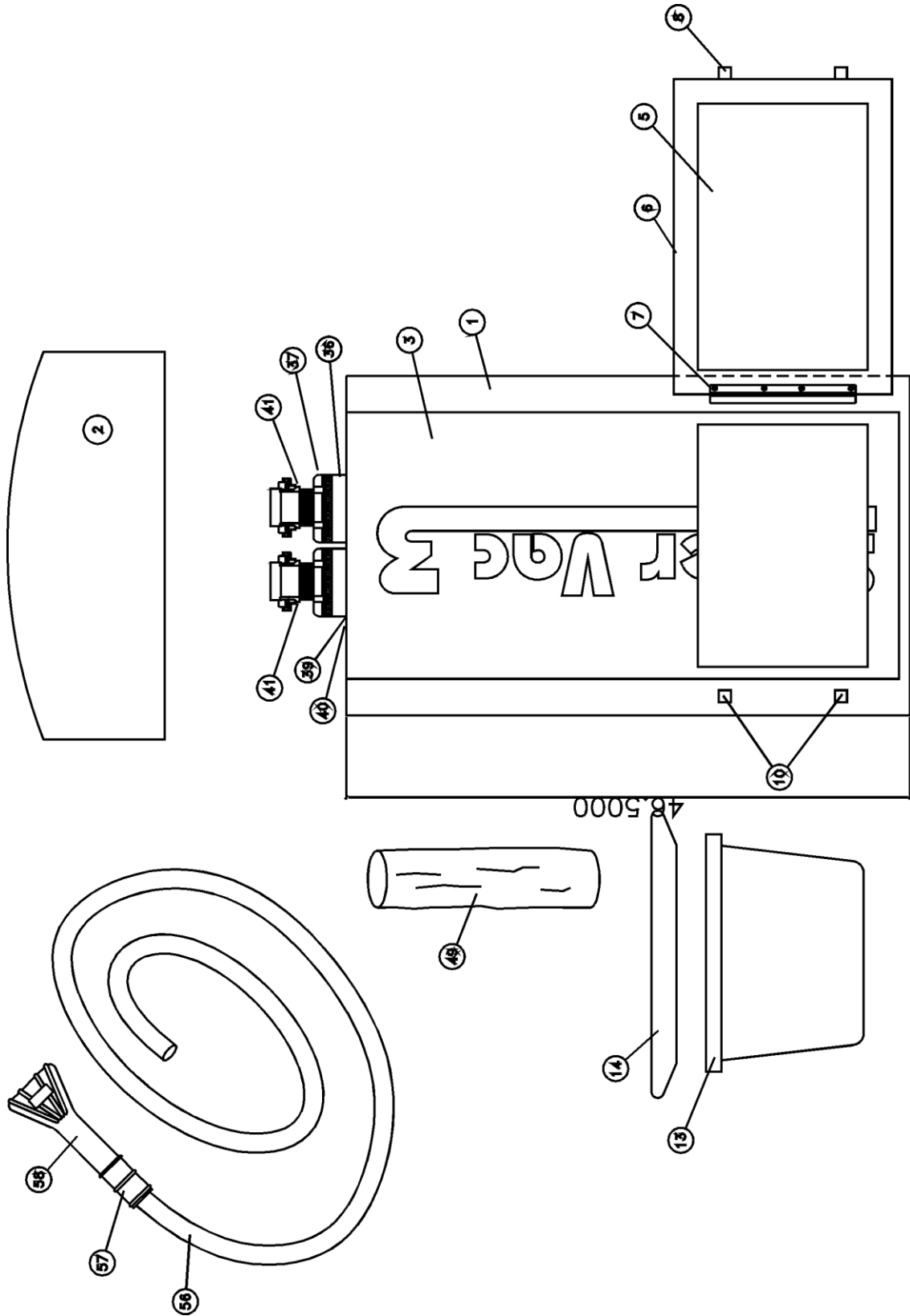

PARTS BREAKDOWN 2

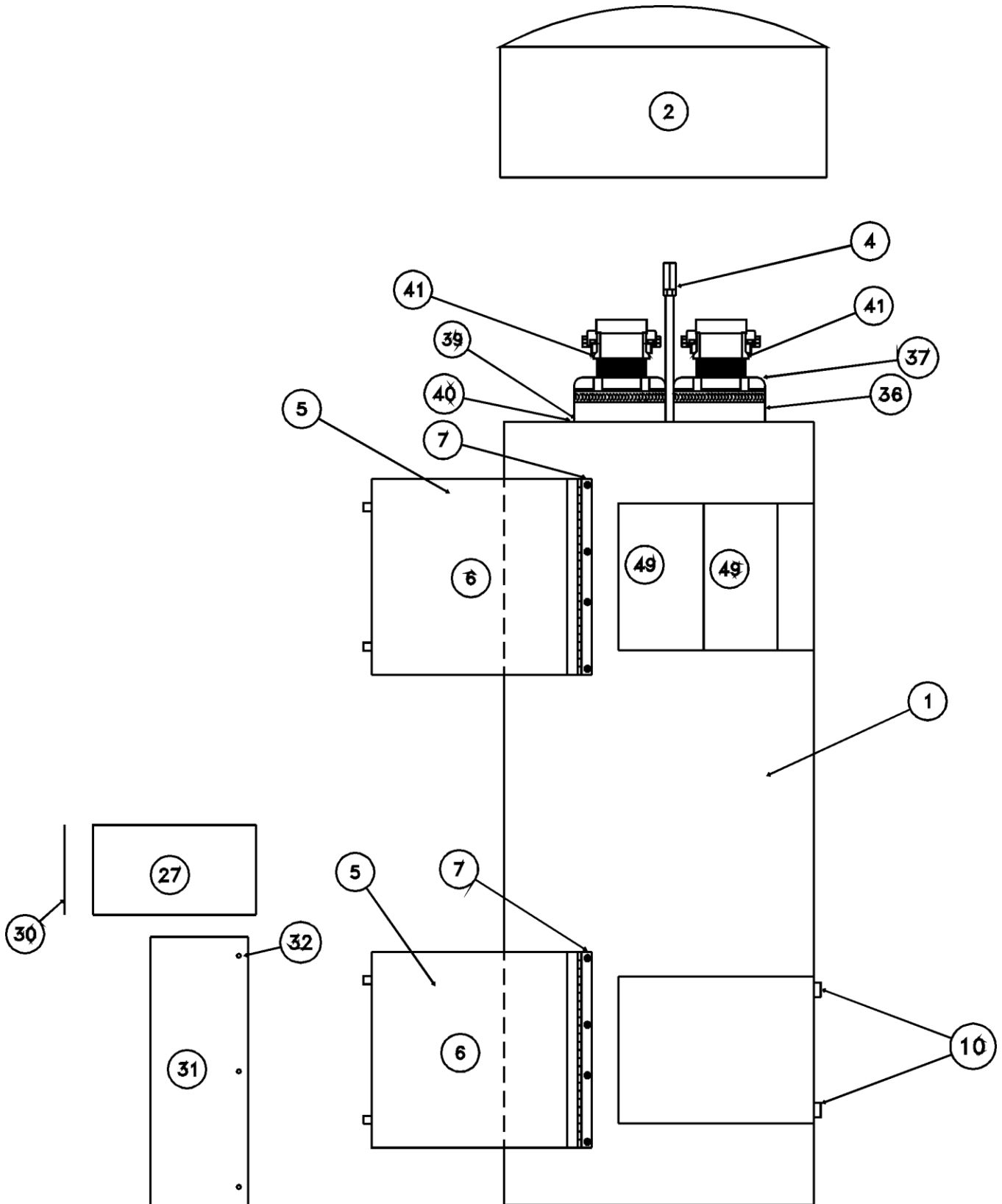

PARTS BREAKDOWN 3

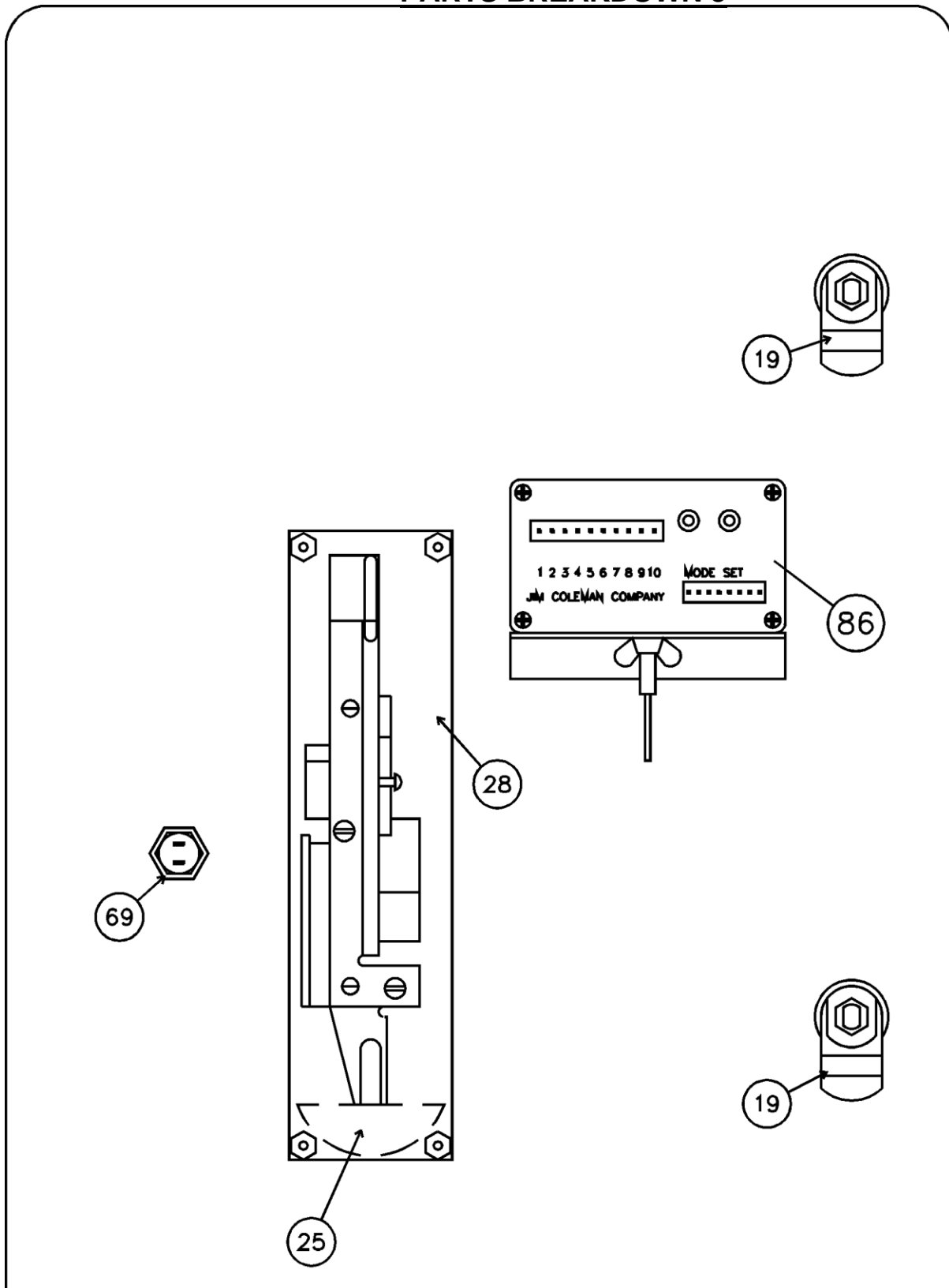

INSIDE VIEW OF SHAMPOOER UNIT 1

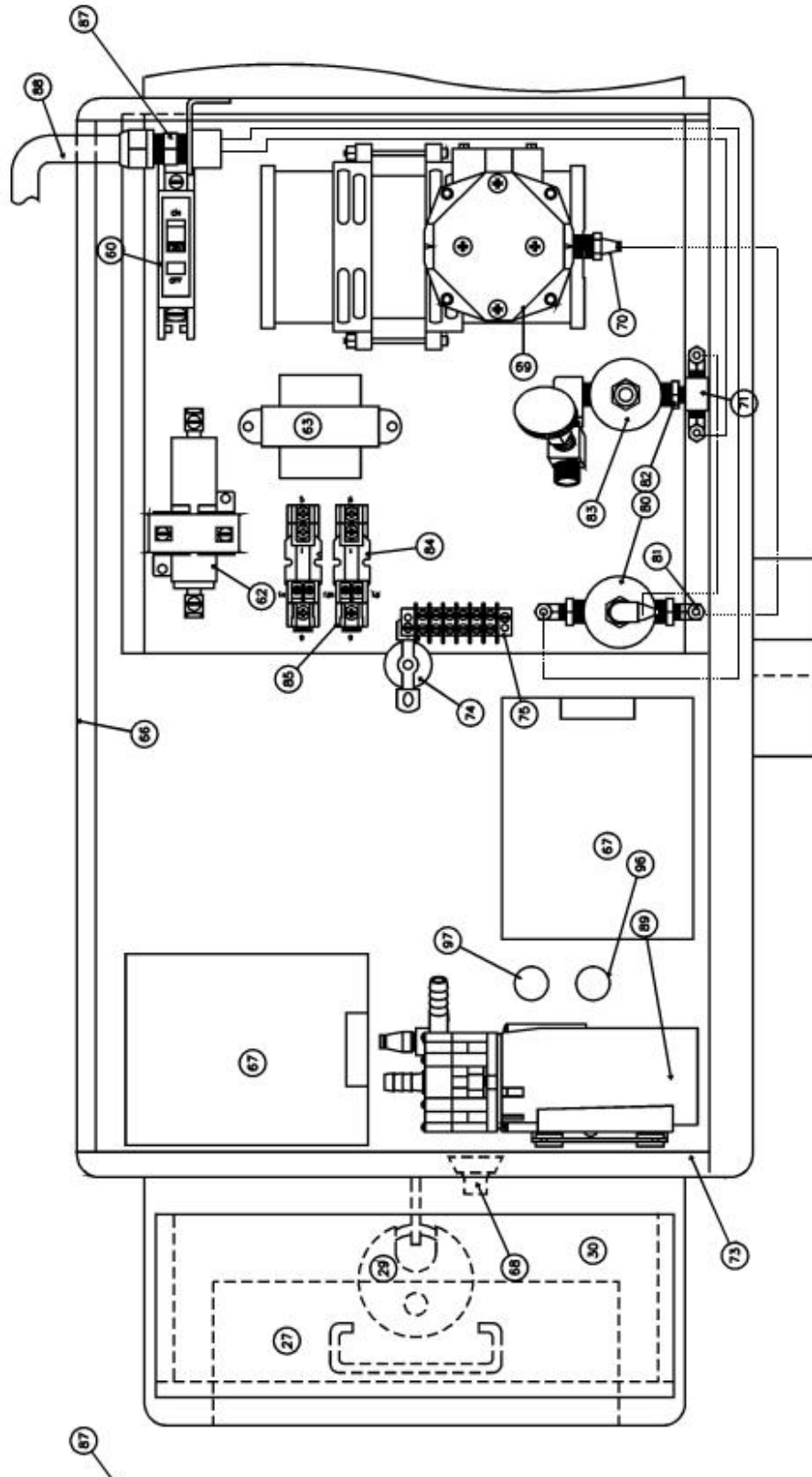

BRUSH HANDLE ASSEMBLY 1

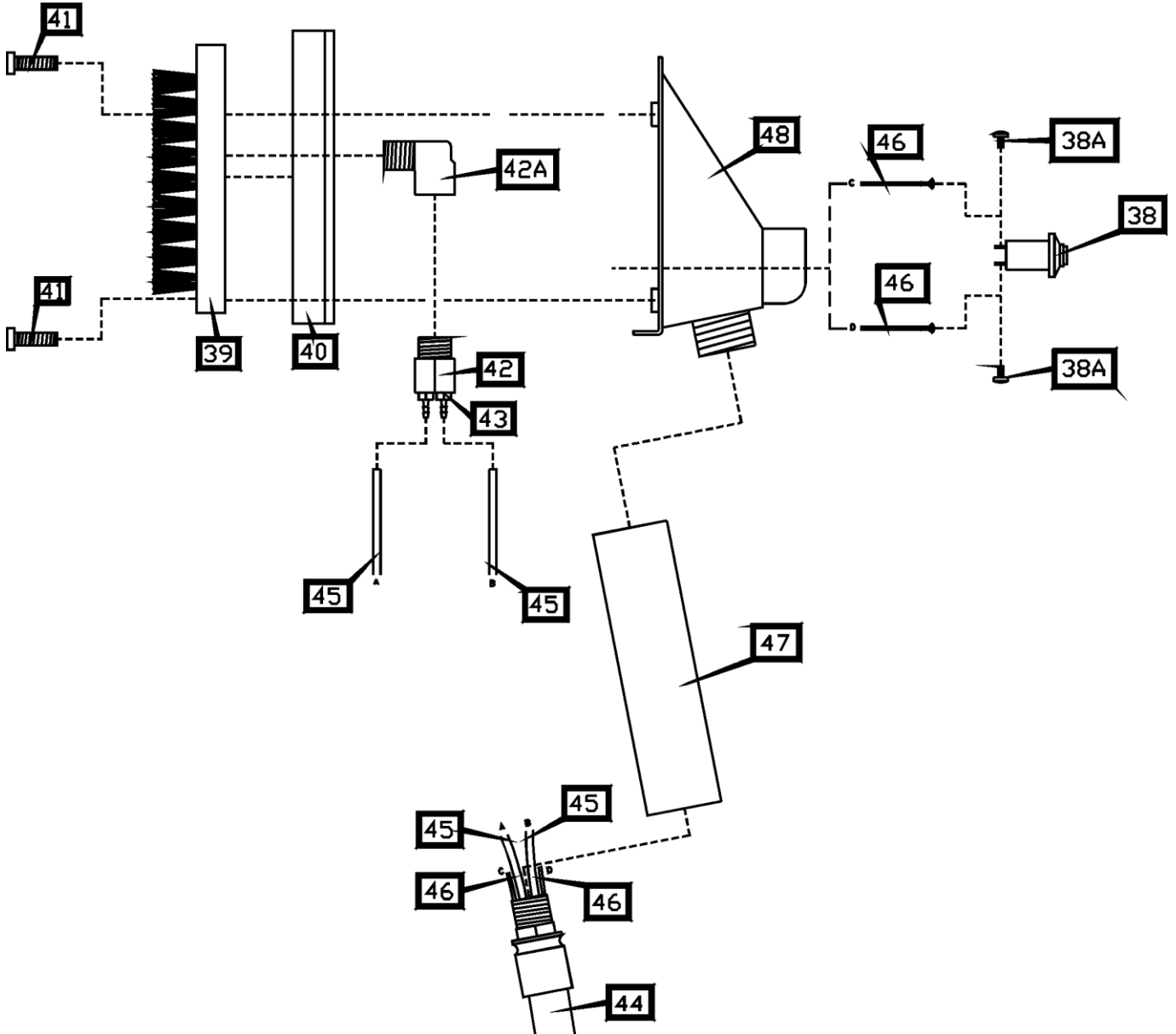

FRONT VIEW OF SHAMPOOER DOOR 1

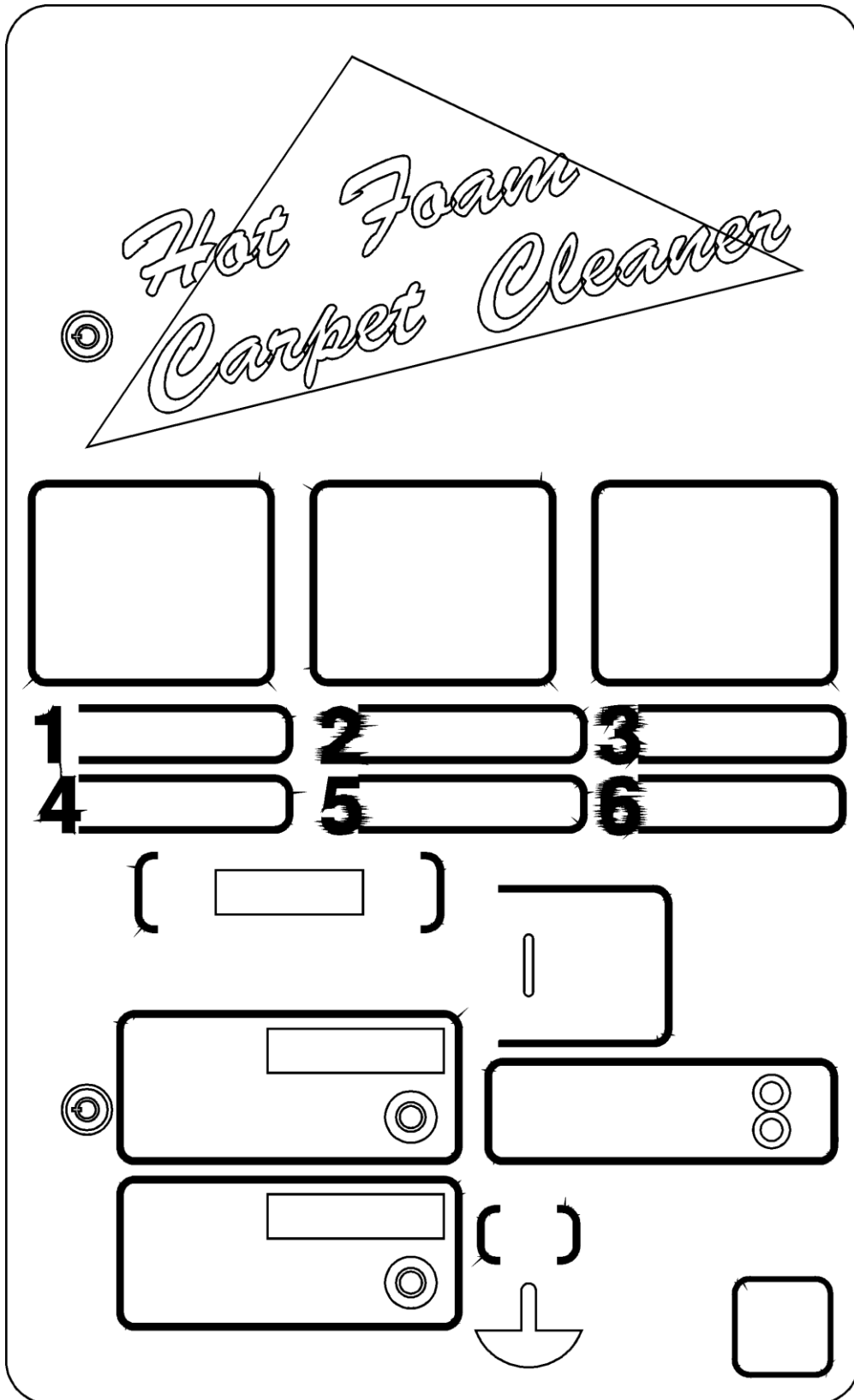

SIDE VIEW OF SHAMPOOER DOOR 1

