

# Fusion Systems: eFusion & FusionX

## Technical Information

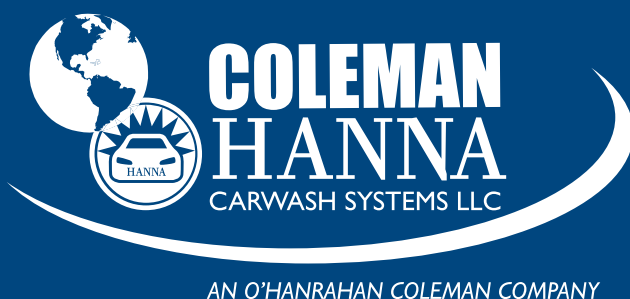

5842 W 34th St • Houston, TX 77092

1.800.999.9878 • 1.713.683.9878

[www.colemanhanna.com](http://www.colemanhanna.com)



Find us on Facebook:

/ColemanHannaCarwash

# FusionX and eFusion

## ***Instructions for loading programs into PLC and Red Lion memory module***

**NOTE:** *When loading v.3.15 or higher, please do not load your existing recipes from previous versions due to program changes that were made in the recipe portion of the program. This is especially important with eFusion units*

### **SAVING EXISTING RECIPES and REVENUE (Recipes and Revenue are stored in the PLC NOT the Red Lion)**

1. With power on to the PLC, insert memory card into the slot in the PLC. Press the F5/Log In Page button and log in using the owner password. Press F6/Memory Card and select Recipe Mode then press Save Recipes twice. Remove the memory card with power still on. **DO NOT CYCLE POWER ON & OFF.**

### **RED LION Operator Interface**

1. Turn off power to the display. Plug memory card into the slot located on the side of the Red Lion.
2. Turn on power to display. Wait for display to load program from memory card. (Observe text – LOADING CF). Once the screen is back to the main screen make sure the HMI number matches the version number you are loading.
3. After program is loaded, turn off power and remove card. Turn power back on.

### **OMRON PLC (Loading Program Instructions)**

1. Turn off power to PLC. Open cover plate (located above the memory card slot) on CJ1G-CPU44 PLC module. Here you'll see 8 switches numbered 1-8 from top to bottom. Turn on DIP SW 7. (push switch to left position). Insert memory card into slot. Card is properly seated when the eject button is even with the top.
2. Turn on power to PLC. Wait for "busy" light to extinguish (about 5 to 10 seconds) and the main screen is up.
3. Turn off power to PLC. Remove memory card. Turn off DIP SW 7 (push switch to right position).
4. Turn on power to PLC.

### **DOWNLOADING SAVED RECIPES**

1. With power on to the PLC, insert the memory card. Press the F5/Log In Page button and log in using the owner password. Press F6/Memory Card and select Recipe Mode then press Load Recipes twice.
2. Remove the memory card with power on. **DO NOT CYCLE POWER ON & OFF**

***REFER TO START UP INSTRUCTIONS FOR SYSTEM INITIALIZATION***

## **Uploading Program from Omron PLC to Compact Flash Card**

The following procedures are the same for Omron CPU12 & 13 on a Water Wizard 2.0 and a CPU44 on Fusion units. **The power must remain on during this entire procedure.**

1. Lift the small door on the Omron PLC. This door is where the Run, Err, Comm, etc. LED lights are located. Behind this door you will find a vertical set of 8 dip switches.
2. Flip dip switch #7 to the left.
3. With power applied to the ECC (main panel), insert the compact flash card into the slot on the Omron PLC.
4. You will see the "MCPWR" light illuminate and the "BUSY" will begin to flash. Once the "BUSY" light extinguishes, press & hold the small button just to the left of these lights. Continue to hold this button in until the "BUSY" light begins to flash again. It is now writing the program to the card. This may take several minutes to complete.
5. Once the "BUSY" light completely stops flashing, the upload is complete. You can now press the eject button, located directly below the compact flash card, and remove the card. Once the card is removed, the "MCPWR" light will extinguish. The program now on the card is an exact copy of what is currently in the PLC including Recipes, Timer, Positioner & Revenue Values.
6. Now flip dip switch #7 back to the right and close the small access door.
7. The unit can now be returned to service.

# ***FusionX and eFusion***

## **Red Lion Operator Interface Function Key Descriptions**

### **F1/Recipe Menu**

- 0 - Current Recipes
- 1 - Assign Recipes
- 2 - Program Recipes
- 3 - Review Recipes
- 4 - Copy & Save Recipes

### **F2/Timers & Counters**

- 0 - Adjust Timers
- 1 - Adjust Gantry Counter
- 2 - View Boom Counters

### **F3/Prices & Revenues**

- 0 - View Revenue
- 1 - Set Wash Prices
- 2 - Best Income
- 3 - Last Ten Washes
- 4 - View Total Washes

### **F4/Wash Data**

- 0 - Wash Status
- 1 - Washes Today
- 2 - Washes Yesterday
- 3 - Boom Status
- 4 - Display Status
- 5 - Wash Time
- 6 - Car Measurement
- 7 - Car Front Counts
- 8 - Car Rear Counts
- 9 - Last 5 Car Counts
- 10 - Car Front Profile

# FusionX and eFusion

## Red Lion Operator Interface Function Key Descriptions (cont.)

### F5/Log In Page

Insert Password

### F6/Memory Card

Recipe Mode  
Revenue Mode

### F7/Tech Menu

0 - View PLC Inputs  
1 - View PLC Outputs  
2 - View Torque  
3 - Test Functions 1  
4 - Test Functions 2  
5 - Test Functions 3  
6 - Force PLC Outputs  
7 - Wheel Test  
8 - Boom Test  
9 - Top Brush Test  
10 - TB Torque Loop  
11 - Left Brush Test  
12 - LB Torque Loop  
13 - Right Brush Test  
14 - RB Torque Loop  
15 - Front Rear Test  
16 - Photo Sensor  
17 - Boom Safety Eyes  
18 - Nozzle Test  
19 - Freeze Test  
20 - Door Status  
21 - Entry Door Test  
22 - Exit Door Test  
23 - Dry Wash Test  
24 - Test Pager  
25 - Set Time Clock  
26 - Scrolling Sign  
27 - Display Contrast  
28 - Reset Wash  
29 - CAT Pump Serviced  
30 - TB No Load Test  
31 - LB No Load Test  
32 - RB No Load Test

### F8/Site Data

0 - Change Passwords  
1 - Pager Values  
2 - Enter IP Address  
3 - On-Board Blower  
4 - Type Cashier  
5 - Enable Cycle Switches  
6 - Recirculating High PH  
7 - Recirculating Low PH  
8 - Undercarriage Sol 1  
9 - Undercarriage Sol 2  
10 - Profile Option  
11 - Profile Mode  
12 - Blower Truck Mode  
13 - Horn Mute Mode  
14 - Static Blower  
15 - Treadle Sensor  
16 - Undercarriage Eye  
17 - Door Mode  
18 - Windy Day Bypass  
19 - Flip Blower Front  
20 - Flip Blower Rear  
21 - Min SB TL Position  
22 - Off Board Sign Type  
23 - Init Gantry Counts  
24 - Spin Freeze Protect

## Fusion Recipe Function Bits

Function #	Red Lion Function Description	Recipe Function Bit Explanation
00	Undercarriage	Turn this ON in Pass 1 to clean the under body of vehicles with High Pressure as they enter the bay.
01	Presoak High pH	Turn this ON to apply an alkaline presoak (or a Foam Bath on eFusion) to the vehicle. This is typically done on Pass 1 and/or Pass2
02	Presoak Low pH	Turn this ON to apply an acid presoak to the vehicle, if equipped. This typically is applied after High pH Presoak and occurs during Pass 2 or Pass 3.
03	Tire Cleaner	Turn this ON to apply a Tire/Wheel Cleaner product to the lower part of the vehicle, if equipped. This is typically applied during a Presoak Pass in Pass 1 or 2.
04	Front Brush Pass	Turn this ON to scrub the front of the vehicle with the brushes. This function is always performed by the Side Brushes.
05	Rear Brush Pass	Turn this ON to scrub the rear of the vehicle with the brushes. This function is performed with the Side Brushes unless the Gantry cannot position far enough behind the vehicle for this to take place. In that case, the unit would automatically scrub the rear of the vehicle with the Top Brush.
06	SB Tilt Solenoid	This would only be turned ON in one Side Brush pass if there are two separate Side Brush passes in your recipe. Turning this ON will hold the Side Brushes vertical to better scrub the lower portion of the vehicle but the upper part of the vehicle will not be cleaned by the brushes.
07	Side Brush Pass	Turn this ON to scrub both sides of the vehicle. This can successfully be done in a single pass provided the "SB Tilt Solenoid" bit is turned OFF.
08	Top Brush Pass	Turn this ON to scrub the top surface of the vehicle. On an eFusion this is required to be done in an odd numbered pass, from front to rear, due to the process used for pick-up truck detection. A FusionX can do this in an even numbered pass, from rear to front, because the boom profile eyes are used for truck detection but we recommend that you do the Top Brush pass in an odd numbered pass whenever possible.
09	Wheel Brushes	Turn this ON to scrub the vehicle wheels. This cannot be done in Pass 1 because the unit has not located the rear wheel until the first pass is complete. We recommend turning this ON during a high pressure pass to limit the number of times the high pressure pump motor is started during a wash.
10	Rocker Panel	Turn this ON to clean the lower portion of the vehicle with high pressure water. (not available on eFusion)
11	High Pressure Wash	Turn this ON to clean/rinse the entire vehicle with high or low pressure water, depending on installed options. Turning this ON will also cause the scrolling sign, if equipped, to display "Washing". This is typically done following the last Presoak or Brush pass.
12	High Pressure Rinse	Turn this ON to rinse the entire vehicle with high or low pressure water, depending on installed options.
13	High Pressure Wax	Turn this ON to deliver a wax product via the high pressure pump, if equipped. This is commonly done on the pass following a Tri-Foam (conditioner) pass in the latter part of the recipe.
14	Bug Pass	Turn this ON in any high pressure pass, in which the wash boom will be going down in the front and/or the rear. This causes the wash boom to repeat the lower 1/3 of its travel two times in one boom pass (completely down, partially up, completely down, then completely up). This is only needed in a touchless wash recipe, to better clean the front or rear of the vehicle with high pressure water.(not available on the eFusion)
15	MedPress Solenoid	Turn this ON to lower the pressure of the high pressure water, if equipped with the "High Pressure Option". This can be used during a High Pressure Wax pass to improve the delivery of the wax.

16	Reclaim Solenoid	Turn this ON to provide a supply of reclaim water to the high pressure pump, if equipped with the "High Pressure Option". If not equipped, a valve will open to supply reclaim water to the Gantry at low pressure. This is typically used in the early portion of the wash recipe in conjunction with any high pressure function.
17	Cold H2O Solenoid	Turn this ON to provide a supply of cold water to the high pressure pump, if equipped with the "High Pressure Option" and the "Hot Water Option". This is typically used in the latter portion of the wash recipe in conjunction with any high pressure function.
18	Spot Free Rinse	Turn this ON to deliver Spot Free water to the Gantry as a final rinse.
19	Tri-Foam	Turn this ON to deliver a Tri-Color Foam product to the Gantry. If you choose to use Tri-Color Foam Detergent, you would apply this early in the wash recipe, typically during a Presoak pass. This configuration will decrease the cycle time of your recipes due to the decrease in necessary passes. If you choose to use a Tri-Color Foam Conditioner, you would apply this near the middle of your recipe to allow other passes to rinse the product off of the vehicle.
20	Low Pressure Wax	Turn this ON to deliver a wax product, through a low pressure pump, to the Gantry. This is typically done preceding the Spot Free Rinse pass.
21	Blower	Turn this ON to activate either On-Board Blowers or Free-Standing Blowers, if equipped.
22	Side Brush Lube	Turn this ON during a Side Brush, Front Brush or Rear Brush passes to wet the vehicle surface just ahead of the Side Brush travel.
23	Top Brush Lube	Turn this ON during a Top Brush pass to wet the vehicle surface just ahead of the Top Brush travel.
24	Rotate HP Rocker	Turn this ON to use the Wheel Brush to remain retracted, rotate and deliver high pressure, if equipped, to the lower portion of the vehicle.
25	Glass Treatment (Windshield Chem)	Turn this ON to deliver a Glass Treatment product (RainX or similiar product) through the Wax Arch on the Gantry. If equipped with this option, the wax rain arch is replaced by an arch that has (6) Fan Type Wax Nozzles.
26	Pipe Rack Mode	Turn this ON, in pass 1, if you wish to create a TOUCHLESS wash recipe where the boom will not contour during the entire duration of that wash, though the boom will come down during front and rear boom passes. This is used to offer a wash recipe for your customers who have pipe or ladder racks on their trucks. Signage would need to be posted at the autocashier to instruct these customers to select ONLY this wash for their vehicle, with the pipe or ladder rack.
27	Rinse Side Only	Turn this ON during a High Pressure Wash, Rinse or Wax pass to deliver through the side High Pressure nozzles only. This can be used to increase the deliver pressure at the vehicle if equipped with the 15 hp High Pressure Option or the Low Pressure configuration on the eFusion.
28	Rinse Top Only	Turn this ON during a High Pressure Wash, Rinse or Wax pass to deliver through the top high pressure nozzles only. This can be used to increase the deliver pressure at the vehicle if equipped with the 15 hp High Pressure Option or the Low Pressure configuration on the eFusion.
29	Tire Glaze	Turn this ON in Pass 1 to activate the Tire Glaze System, if equipped, at the end of the wash.
30	Static Blower	Turn this ON in the last pass if you wish to use your On-Board Blower unit to operate as if it had Free-Standing Blowers. Your customers must drive through the Gantry at the end of the wash rather than the Gantry traveling over the vehicle. This is not commonly used.
31	Rear Top Brush Pass	Turn this ON in any brush pass where you want the Top Brush to scrub the rear of the vehicle. This can be used alone to clean the rear or used in conjunction with the "Rear Brush Pass", which uses the Side Brushes to scrub the rear.



# eFusion SYSTEM START-UP

## Do Not Turn On Power Until Directed To Do So

- Step 1 **(Systems w/ high pressure option)** Flush incoming water line before filling the water tanks on the eFusion. Connect Water Line and fill rinse tank. Check to make sure water is clean with no cloudy residue. If the water is cloudy or dirty, continue to flush lines.
- Step 2 Fill Concentrate Tanks with quality chemicals.
- Step 3 If system has high pressure option, remove the tips in the undercarriage bar and high-pressure gantry arch and then flush the lines. To do this, follow the steps listed in the "Test Screen".
- Step 4 Turn on the air compressor and set to approximately 100 PSI. Adjust pressure on gantry mounted regulator to 100 PSI.
- Step 5 Turn off the Electrical Disconnect Switch on Gantry. Turn on Electrical Disconnect Switch on Electrical Control Center ("ECC") inside Equipment Room. The Red Lion Operator Interface Panel should come on.
- Step 6 Press the F7 "Tech Menu" button and scroll to Test Function. Turn on Presoak for about 2-3 minutes to flush line and get product to the Gantry. Turn on Tire Cleaner for about two (2) minutes. Turn on Rinse to flush lines then turn off. Continue to test services until you test all functions that apply to your machine. Modify low pressure applications by adjusting air pressure using the regulators inside the low pressure box.
- Step 7 Turn on the Manual Operation Toggle Switch located inside the Gantry Control Panel mounted on the gantry. Turn on power at Electrical Disconnect Switch located on Gantry. Check the rotation of the drive motors by pressing the Drive Reverse Switch. This should cause the unit to travel away from home position. If not, then have a qualified electrician change the incoming 3-phase power to correct the rotation.

Press the Top Brush Down and it should lower. Use these manual buttons to test all the gantry functions for proper operation. Also use the buttons the check brush rotation and operation. **(SEE ROTATION CHARTS ON PAGES 17 & 18)**





Step 8 Move the unit up and down the track by pressing the Drive Forward and Drive Reverse Switches. Make sure the Prox Switches are set properly to read the Home and End of Track targets. They should have approximately 3/8ths inch clearance.

Step 9 **INITIALIZING THE SYSTEM**

First perform a “Wheel test, Side Brush, Top Brush and Boom Test”. These tests can be accessed in the “F7 Tech Menu” of the Red Lion Interface Panel. This test will allow the PLC to store the correct length of travel for each of these components. ***THIS MUST BE DONE TO ENSURE PROPER OPERATION***

Next you ***MUST*** save the Treadle position that is required for the wheel brush to locate vehicle front wheels. This setting is done in “F2 Adjust Gantry Counts”. The best way to accomplish this is to park a vehicle on the treadle plate and with the gantry in manual mode, position the gantry until the wheel brushes are aligned with the exact center of the front wheels. Press the “Wheel Brush Extend” manual push button to confirm alignment. Now press “Save” on the Red Lion Display to store this position.

**Assigning Recipes:** Assign the Recipes in “F1 Recipe Menu” that you wish to use. Factory recipes are listed in your manual for both combination and touchfree wash cycles.

**IMPORTANT: Brush No Load Tests**

1. Go to “F7-Tech Menu” on your Red Lion. Use the Raise key until you get to Menu Option 30 – “TB No Load Test” and press Enter. See the pictures below.
2. Now you need to switch the Gantry manual toggle switch “On” and **lower the Top Brush** about 18-24” to get the brush **out of the nest** then press the arrow under the display on the Red Lion, where it says “Test”. The word “Off” will change to “Testing”.
3. The Top Brush will begin to spin and you will see the “PV” value begin to change (PV = Present Value).
4. After about 8 seconds, you will see that the “NL” value has now been set (NL = No Load).
5. If the brush components are in good mechanical condition and **the brushes were not in contact with any surface**, the test is complete. You can now press the arrow under the display, where it says “Accept”. The word “Off” will change to “Writing”.
6. When the word “Off” returns under “Accept”, this brush test is complete.



7. You can now press the "Prev" button then raise up to Menu Option 31 – LB No Load Test and Menu Option 32 – RB No Load Test and repeat the procedures above for each brush.
8. These procedures are required to calibrate the acceptable no load brush torque based on the incoming voltage at your site. **NOTE: These procedures will have to be repeated periodically to recalibrate acceptable no load torque after some time in service due to normal mechanical wear. It is recommended repeat at least once within the first 30 days of operation and as needed thereafter.**

```
Technician Menu
Raise/Lower selects..
Menu Option: 30
TB No Load Test
Enter Selects Option
```

```
TB No Load Torq
Capture NL torque
PU: 0.1 %
NL: 37.9 %
% NL - 99.9 %
Test Off Accept Off
```

```
Technician Menu
Raise/Lower selects..
Menu Option: 31
LB No Load Test
Enter Selects Option
```

```
LB No Load Torq
Capture NL torque
PU: 0.0 %
NL: 37.9 %
% NL -100.1 %
Test Off Accept Off
```

```
Technician Menu
Raise/Lower selects..
Menu Option: 32
RB No Load Test
Enter Selects Option
```

```
RB No Load Torq
Capture NL torque
PU: 0.0 %
NL: 44.1 %
% NL - 99.9 %
Test Off Accept Off
```

### Site Data Settings

Step 10 Press F5 and enter the "Owner" password. The default password is "1234". Then Press F8 and scroll through each option. Set each option to match your equipment. Example; if you have on-board blowers you must enter "Equipped". If no blowers or if the blowers are free standing, then select "Not equipped".

Scroll through the remaining screens and select the option that matches your equipment package.



Step 11 You are now ready to test the unit on a car. Pull vehicle into bay and place in park position with front wheel on stop station. Press the Cycle 1 button on the Electrical Panel and watch the eFusion go through the wash process. Check for leaks and correct as needed. Once completed, press cycle 2 Button and monitor wash process. Repeat the same procedure for Cycle 3 and 4. Only after washing several vehicles should you need to adjust the different chemicals that are being applied to the car.

- Test the eFusion many times to ensure it is functioning properly.
- Refer to “Brush Position Settings” beginning on Page 5 for adjustments to brush positions.
- Check all Prox Switch settings to ensure there is a gap of at least 3/8”.
- Check all Proxes to ensure they are exactly square with their target.

## Wheel Scrub Features and Set-up Instructions

You will find a recipe bit titled “Wheel Brushes” in the Program Recipe menu. A custom recipe is required to apply this function to a wash recipe. You cannot perform the wheel brush step on the first pass of a wash recipe. The wheel brush photo eye must first find the rear wheel position.

### ***Air Pressure Adjustments***

There are two air regulators to move the brushes in and out, one of them to extend and one to retract. The extend regulator adjustment is very critical and should be adjusted to the lowest possible operating pressure, usually about 20 psi. Very little pressure is required to clean the vehicle wheels and too much air pressure could cause unnecessary load and wear on the wheel brush spindle gearmotors. The retract regulator should be adjusted so the brushes return smoothly but positively into their home position, usually about 30 psi.

### ***Timers***

There are also two timers and two counters associated with this option. Under “F2-Timers & Counters” on the Red Lion, go to the “Adjust Timers” menu (Menu Option 0) and press the “Enter” button until you see a timer called “Wheel Brush Dwell”. This timer determines how long the brush will stay engaged in the wheel in each direction (clockwise & counter-clockwise). This is factory set to 3 seconds.

Press the “Next” button to advance to the “Wheel Brush Retract Dwell” timer. This timer determines how long the brush disengages from the wheel between direction changes. This timer is factory set to 1 second. You want the brushes to disengage the wheel slightly while it changes directions. If it does not, you would want to increase this timer value.



### **Counters**

Since we always know where the front tire will be because of the Treadle, we use that to our advantage. Under "F2-Timers & Counters", go to "Adjust Gantry Counts" menu (Menu Option 1) and press the "Enter" button. There you will see an adjustable counter titled "Treadle Position".

### **Setting Front Wheel Counter**

To set this counter, put the gantry in manual mode (turn toggle switch in gantry panel 'on'), and manually position the gantry until the wheel brush is perfectly aligned with the center of the treadle eye. It is best if there is a vehicle parked properly on the treadle plate to achieve the best result. Manually extend the wheel brush to assure you are in the proper position using the manual push buttons for the Wheel Brush located in the gantry control panel.

Once you have achieved this position go back to the Red Lion and press the arrow key that is located directly below the center of the screen, below the word "Off" on the display. This word will then change to "On". You will see the value under the word "Treadle" change. You have now set where the wheel brush will position at the front tire when the wheel brush function is performed in a wash recipe.

### **Setting Rear Wheel Counter**

The wheel brush photo eye will locate the rear wheel position in pass 1. This position is also adjustable. Watch it wash a variety of vehicles to determine if the rear wheel position should be adjusted.

If you determine that this adjustment must be done, Under "F2-Timers & Counters", go to "Adjust Gantry Counts" menu (Menu Option 1) and press the "Enter" button. Now press the "Next" button repeatedly until you see a counter called "Rear Wheel Offset".

If you need to adjust the rear wheel brush position closer to the front of the vehicle, you should decrease this counter. If you need to adjust the rear wheel brush position closer to the rear of the vehicle, you should increase this counter. The counters on the eFusion and the FusionX are incremented in inches. If the Wheel Brush always positions about 2 inches past the center of the rear wheels, you can decrease the counter setting by 2 inches.



## FusionX and eFusion

### *Instructions for loading OMRON PLC and Red Lion memory module*

#### **SAVING EXISTING RECIPES and REVENUE (*Recipes and Revenue are stored in the PLC NOT the Red Lion*)**

1. With power on to the PLC, insert memory card into the slot in the PLC. Press the F5/Log In Page button and log in using the owner password. Press F6/Memory Card and select Recipe Mode then press Save Recipes twice. Remove the memory card with power still on.
2. **DO NOT CYCLE POWER ON & OFF.**

#### **RED LION Operator Interface**

1. Turn off power to the display. Plug memory card into the slot located on the side of the Red Lion.
2. Turn on power to display. Wait for display to load program from memory card. (Observe text – LOADING CF). Once the screen is back to the main screen make sure the HMI number matches the version number you are loading.
3. After program is loaded, turn off power and remove card from display. Turn power back on.

#### **OMRON PLC (Loading Program Instructions)**

1. Turn off power to PLC. Open cover plate (located above the memory card slot) on CJ1G-CPU44 PLC module. Here you'll see 8 switches numbered 1-8 from top to bottom. Turn on DIP SW 7. (push switch to left position). Insert memory card into slot. Card is properly seated when the eject button is even with the top.
2. Turn on power to PLC. Wait for "busy" light to extinguish (about 5 to 10 seconds) and the main screen is up.
3. Turn off power to PLC. Remove memory card. Turn off DIP SW 7 (push switch to right position).
4. Turn on power to PLC.

#### **DOWNLOADING SAVED RECIPES**

1. With power on to the PLC, insert the memory card. Press the F5/Log In Page button and log in using the owner password. Press F6/Memory Card and select Recipe Mode then press Load Recipes twice.
2. Remove the memory card with power on. **DO NOT CYCLE POWER ON & OFF**



## eFusion Start Up Brush Position Settings

The following settings are based on the center line of the treadle eye being located 70 inches from the entrance end of the home prox target. Any variance in this dimension will require adjustments to the brush start positioners for proper operation. **See the chart on page 7 for factory default settings.**

These settings are located in the F2 Timers and Counters button on the Red Lion.

```
Timers & Counts
Raise/Lower selects..
Menu Option: 1
Adjust Gantry Cntr
Enter selects option
```

First set the wheel brush position for the front wheel. Since we always know the position of the front wheel, we can set this dimension as a fixed distance. Manually move the gantry to where the center of the wheel brush is at the center line of the eye on the treadle. Then press Enter. This will lock in this position for all wash cycles.

```
Treadle Position
Center wheel brushes
on centerline of
treadle. Press Enter
Gantry  Enter  Treadle
0.0    Off    34.5
```

This screen sets the gantry position when the rinse spray starts at the front of the car. Decrease the number to move the brush closer to the exit end of the wash bay.

```
Start Gantry
at front of car
Stop Gantry in front
of measurement eye...
- 21.0 "
```

This screen sets the gantry position when the rinse spray starts at the rear of the car. Decrease the number to move the brush closer to the exit end of the wash bay.

A green screen with black text. The text reads: "Start Gantry at rear of car", "Stop Gantry past the measurement eye ...", and "+ 30.0 "" in a black box at the bottom.

**Start Gantry  
at rear of car**  
Stop Gantry past the  
measurement eye ...  
**+ 30.0 ""**

This screen sets the gantry position when the side brushes wash the front of the car. Decrease the number to move the brush closer to the exit end of the wash bay.

A green screen with black text. The text reads: "Front Brush Pass Position", "Stop Gantry in front of measurement eye...", and "+ 17.0 "" in a black box at the bottom.

**Front Brush Pass  
Position**  
Stop Gantry in front  
of measurement eye...  
**+ 17.0 ""**

This screen sets the gantry position when the side brushes wash the rear of the car. Increase the number to move the brush toward the entrance end of the wash bay.

A green screen with black text. The text reads: "Rear Brush Pass Position", "Stop Gantry relative to measurement eye...", and "+ 44.0 "" in a black box at the bottom.

**Rear Brush Pass  
Position**  
Stop Gantry relative  
to measurement eye...  
**+ 44.0 ""**

This screen sets the gantry position at the front when the side brushes wash the sides of car. Decrease the number to start the side brushes more towards the exit end of the wash bay.

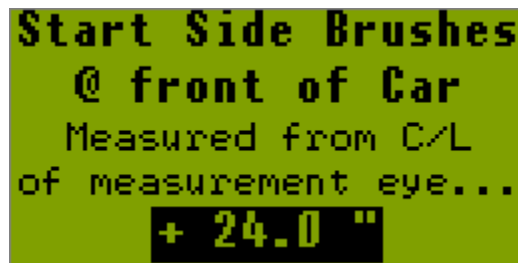
A screenshot of a control screen with a green background and black text. The text reads: "Start Side Brushes @ front of Car Measured from C/L of measurement eye... + 24.0 ""

This screen sets the gantry position at the rear when the side brushes wash the sides of car. Increase the number to start the side brushes more towards the entrance end of the wash bay.

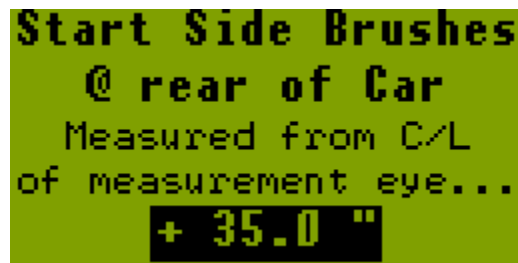
A screenshot of a control screen with a green background and black text. The text reads: "Start Side Brushes @ rear of Car Measured from C/L of measurement eye... + 35.0 ""

This screen sets the gantry position at the front where the top brush begins to wash the top of the car. Decrease the number to start the top brush more towards the exit end of the wash bay.

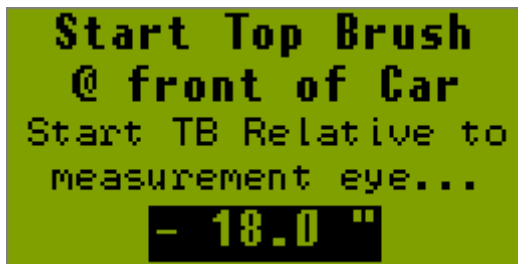
A screenshot of a control screen with a green background and black text. The text reads: "Start Top Brush @ front of Car Start TB Relative to measurement eye... - 18.0 ""

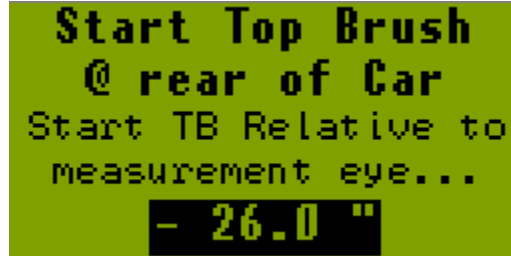

This screen sets the gantry position at the rear where the top brush begins to wash the top of the car. Increase the number to start the top brush more towards the entrance end of the wash bay.

A screen capture showing the following text:

**Start Top Brush  
@ rear of Car**  
Start TB Relative to  
measurement eye...  
**- 26.0 "**

This screen sets the gantry position for the Low Pressure Wax delivery at the vehicle front. Decrease the number to start the LP Wax more towards the exit end of the wash bay.

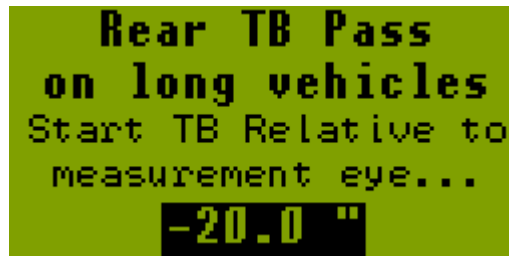
A screen capture showing the following text:

**Rear TB Pass  
on long vehicles**  
Start TB Relative to  
measurement eye...  
**-20.0 "**

This screen sets the gantry position for the Low Pressure Wax delivery at the vehicle front. Decrease the number to start the LP Wax more towards the exit end of the wash bay.

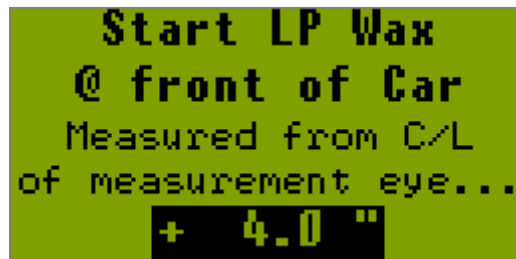
A screen capture showing the following text:

**Start LP Wax  
@ front of Car**  
Measured from C/L  
of measurement eye...  
**+ 4.0 "**

This screen sets the gantry position for the Low Pressure Wax delivery at the vehicle rear. Increase the number to start the LP Wax more towards the entrance end of the wash bay.

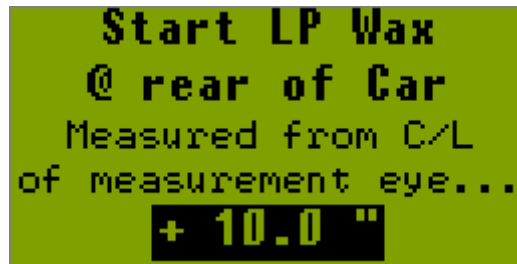
A green LCD screen with black text. The text reads: "Start LP Wax @ rear of Car", "Measured from C/L of measurement eye...", and "+ 10.0 ""."/>

```
Start LP Wax
@ rear of Car
Measured from C/L
of measurement eye...
+ 10.0 ""
```

This screen sets the gantry position for the Triple Shine Conditioner delivery at the vehicle front. Decrease the number to start the LP Wax more towards the exit end of the wash bay.

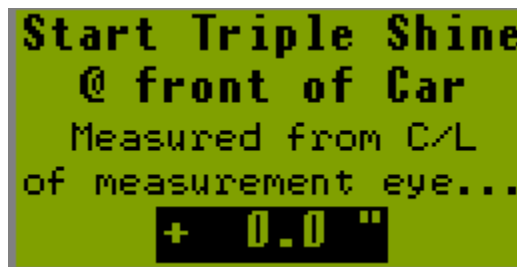
A green LCD screen with black text. The text reads: "Start Triple Shine @ front of Car", "Measured from C/L of measurement eye...", and "+ 0.0 ""."/>

```
Start Triple Shine
@ front of Car
Measured from C/L
of measurement eye...
+ 0.0 ""
```

This screen sets the gantry position for the Triple Shine Conditioner delivery at the vehicle rear. Increase the number to start the LP Wax more towards the entrance end of the wash bay.

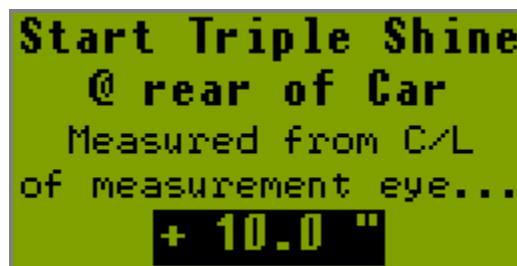
A green LCD screen with black text. The text reads: "Start Triple Shine @ rear of Car", "Measured from C/L of measurement eye...", and "+ 10.0 ""."/>

```
Start Triple Shine
@ rear of Car
Measured from C/L
of measurement eye...
+ 10.0 ""
```

This screen sets the gantry position for the Presoak delivery at the vehicle front. Decrease the number to start the Presoak more towards the exit end of the wash bay.

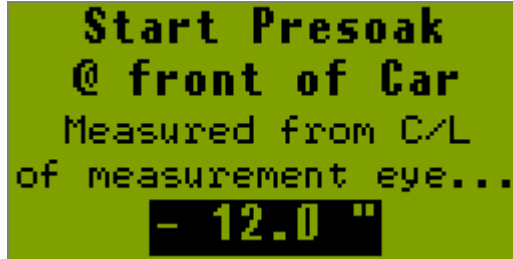
A green screen with black text. The text reads: "Start Presoak @ front of Car Measured from C/L of measurement eye... - 12.0 ""

This screen sets the gantry position for the Presoak delivery at the vehicle rear. Increase the number to start the Presoak more towards the entrance end of the wash bay.

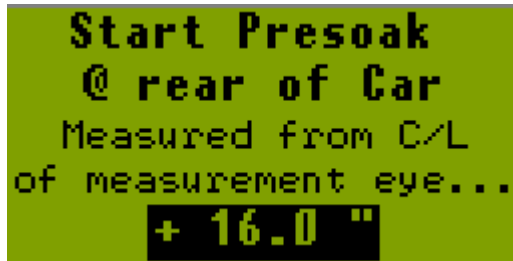
A green screen with black text. The text reads: "Start Presoak @ rear of Car Measured from C/L of measurement eye... + 16.0 ""

This screen sets the gantry position for the Rocker Panel Sprayers delivery at the vehicle front. Decrease the number to start the RPS more towards the exit end of the wash bay.

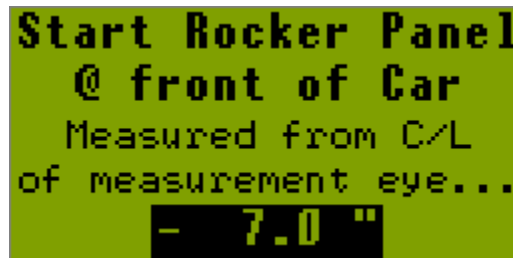
A green screen with black text. The text reads: "Start Rocker Panel @ front of Car Measured from C/L of measurement eye... - 7.0 ""



This screen sets the gantry position for the Rocker Panel Sprayers delivery at the vehicle rear. Increase the number to start the RPS more towards the entrance end of the wash bay.

A screenshot of a control screen with a black background and green monospace text. The text reads: "Start Rocker Panel @ rear of Car", "Measured from C/L of measurement eye...", and "+ 28.5 \"

This screen sets the gantry position for the HP Side Spray delivery at the vehicle front. Decrease the number to start the HP Side Spray more towards the exit end of the wash bay.

A screenshot of a control screen with a black background and green monospace text. The text reads: "Start Side Sprays @ front of Car", "Measured from C/L of measurement eye...", and "- 15.0 \"

This screen sets the gantry position for the HP Side Spray delivery at the vehicle rear. Increase the number to start the HP Side Spray more towards the entrance end of the wash bay.

A screenshot of a control screen with a black background and green monospace text. The text reads: "Start Side Sprays @ rear of Car", "Measured from C/L of measurement eye...", and "+ 25.0 \"

This screen sets the gantry position for the Tire Cleaner delivery at the vehicle front. Decrease the number to start the Tire Cleaner more towards the exit end of the wash bay.

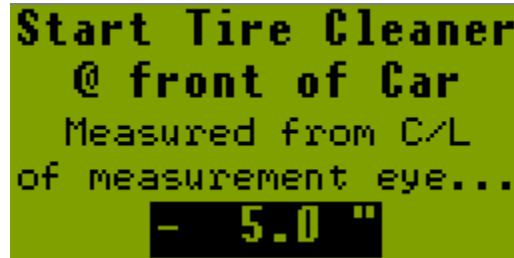
A screenshot of a green monochrome display. The text reads: "Start Tire Cleaner @ front of Car Measured from C/L of measurement eye... - 5.0 ""

This screen sets the gantry position for the Tire Cleaner delivery at the vehicle rear. Increase the number to start the Tire Cleaner more towards the entrance end of the wash bay.

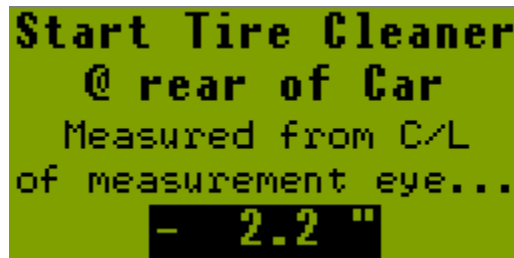
A screenshot of a green monochrome display. The text reads: "Start Tire Cleaner @ rear of Car Measured from C/L of measurement eye... 2.2 ""

This screen sets the gantry position for the Side Brush Lube delivery at the vehicle front. Decrease the number to start the Side Brush Lube more towards the exit end of the wash bay.

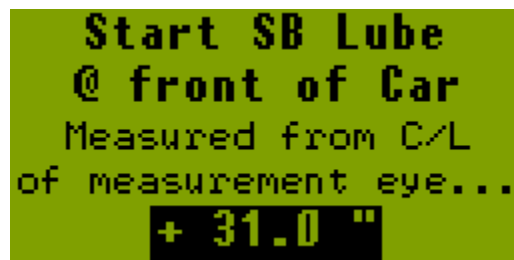
A screenshot of a green monochrome display. The text reads: "Start SB Lube @ front of Car Measured from C/L of measurement eye... + 31.0 ""

This screen sets the gantry position for the Side Brush Lube delivery at the vehicle rear. Increase the number to start the Side Brush Lube more towards the entrance end of the wash bay.

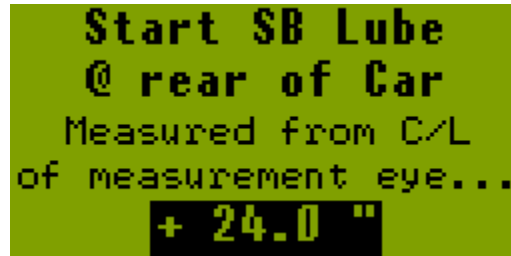
A green LCD screen with black text. The text reads: "Start SB Lube @ rear of Car Measured from C/L of measurement eye... + 24.0 ""

This screen sets the gantry position for the Top Brush Lube delivery at the vehicle front. Decrease the number to start the Top Brush Lube more towards the exit end of the wash bay.

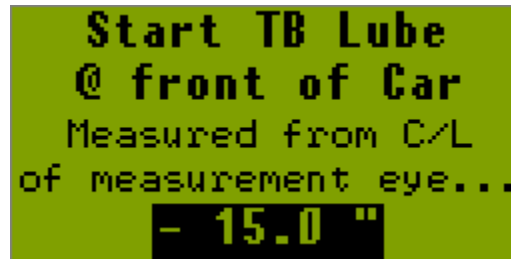
A green LCD screen with black text. The text reads: "Start TB Lube @ front of Car Measured from C/L of measurement eye... - 15.0 ""

This screen sets the gantry position for the Top Brush Lube delivery at the vehicle rear. Increase the number to start the Top Brush Lube more towards the entrance end of the wash bay.

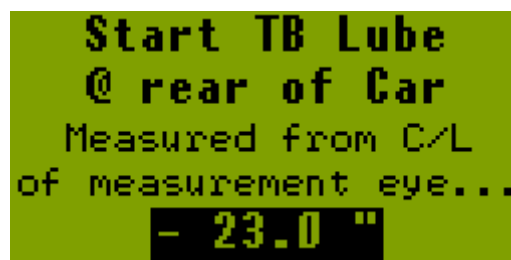
A green LCD screen with black text. The text reads: "Start TB Lube @ rear of Car Measured from C/L of measurement eye... - 23.0 ""

This screen sets the Top Brush Lower Limit at the rear of the vehicle. This is how far the top brush will lower during a rear brush pass that is accomplished with the top brush (when the side brushes cannot reach the rear of a long vehicle). The distance is counted from the Top Brush home position down.

A screenshot of a green screen with black text. The text reads: "TB Lower Limit @ rear of Car", "The max dist the TB will move on TB pass", and "+ 66.0 "".

This screen adjusts the Wheel Brush position for the rear wheel only. The front wheels are set according to the treadle position. A negative number moves the wheel brush towards the exit end.

A screenshot of a green screen with black text. The text reads: "Wheel Brush Offset @ rear of Car", "Measured from C/L of measurement eye...", and "+ 0.0 "".

This screen adjusts the position for the oscillating blower to reverse directions at the front of the car. A lower number moves the flip position towards the exit end.

A screenshot of a green screen with black text. The text reads: "Flip Blower @ front of Car", "Measured from C/L of measurement eye...", and "+ 90.0 "".

This screen adjusts the Wheel Brush position for the rear wheel only. The front wheels are set according to the treadle position. A negative number moves the wheel brush towards the exit end.



### On-board 3 position LED Light Set-up Instructions

You can change the output pattern of your LED lights on your 3 position sign. They can be on: steady, slow steady flash, or a fast strobe affect flash. The instructions below will explain the procedures for making this change. **You may also need to follow these same instructions if your light does not come on immediately when the signal is sent.**

1. With the plastic light fixture removed from the stainless steel enclosure in the gantry, go to "F7-Tech Menu", and then go to "Test Functions 2 (Menu Option 4) in the Red Lion. Toggle the corresponding function on to turn on the light that you wish to modify the pattern. Toggle on the "Enter Now" for the green light. Toggle on the "Stop" for the red light. Toggle on the "Back-up" for the yellow light.
2. You will need to uncap the LED's white wire and the LED's red wire to make this change. The red wire will have a signal wire connected to it as well. The color of this additional wire varies depending on which light you are changing.
3. With the light turned on, hold the white to the red wire and the signal wire for 5 seconds, then remove the white.
4. Disconnect the red wire and the signal, then reconnect it. The fixture should turn on immediately; if not, repeat step 3.
5. To control the flashing rate, touch the white wire to the red wire while its still connected to the signal wire and observe the pattern change.
6. Repeat touching the white and red wires until desired pattern is selected.
7. Once this is done, install a cap on the white wire. Install a cap on the red wire and the signal wire, which are connected together.
8. Install the plastic light fixture into the stainless steel enclosure.



**EXIT END OF BAY**

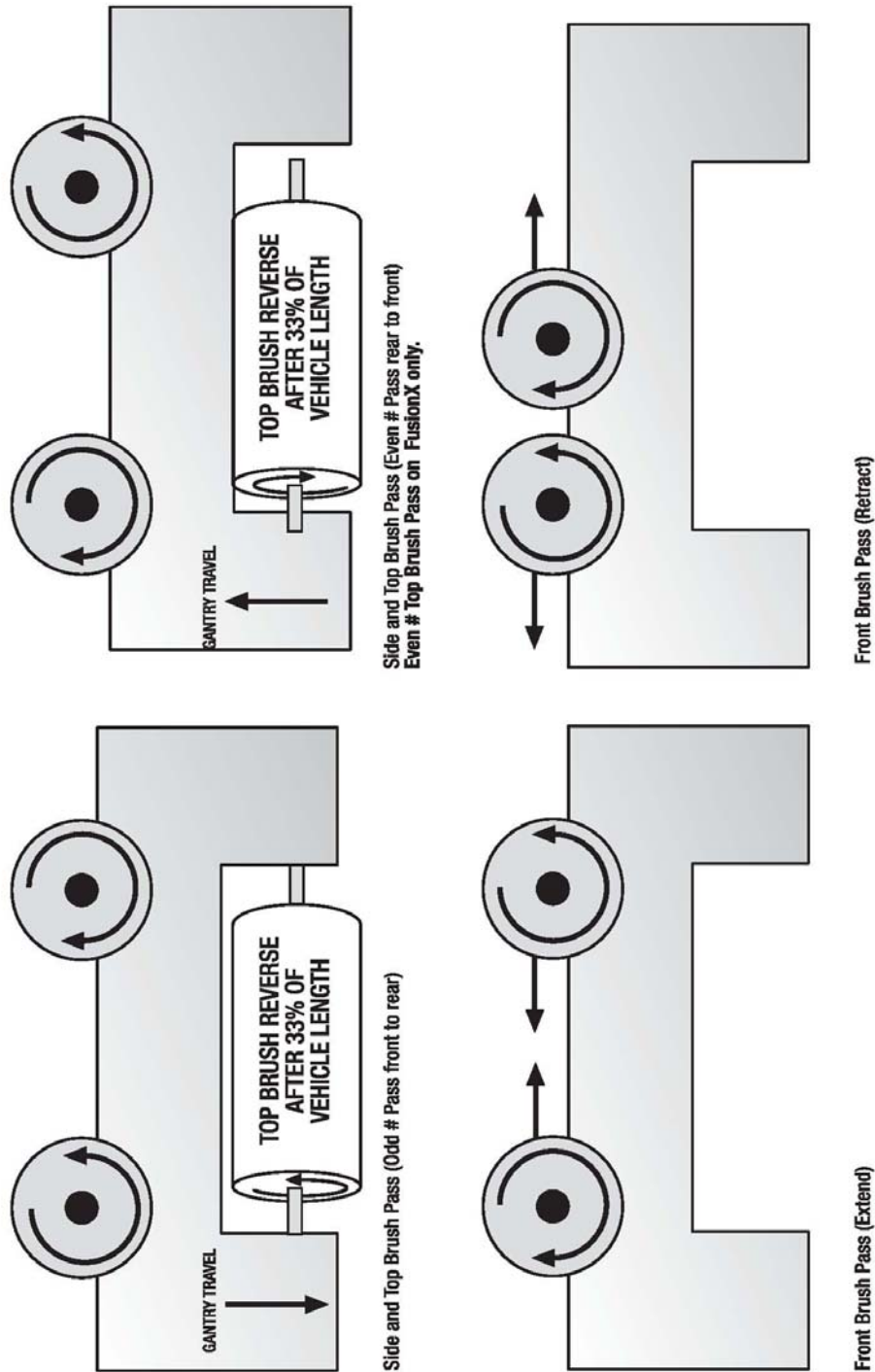

**EXIT END OF BAY**

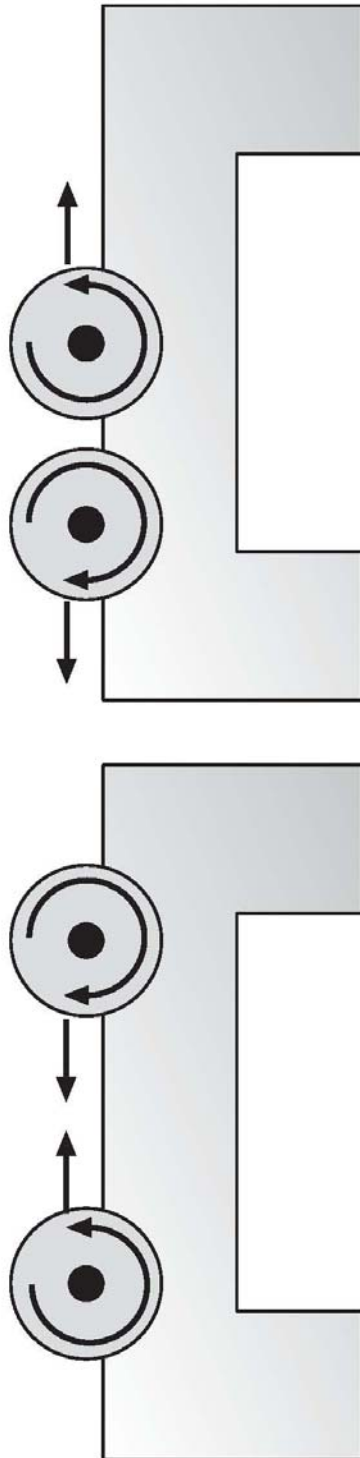

Rear Brush Pass (Retract)

Rear Brush Pass (Extend)

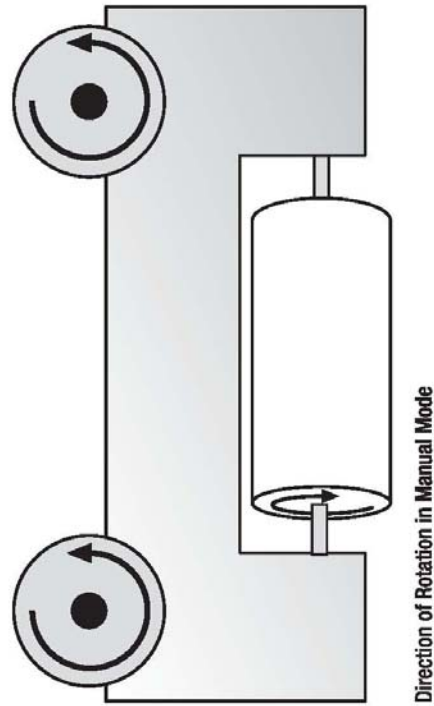

Direction of Rotation in Manual Mode



## ***Safety Signs***

Jim Coleman Company recommends that you have **warning** or **safety signs** at the entrance and exit locations of the automatic wash bay. These signs should be mounted where they are visible from the Entrance and Exit locations of the wash bay. These warning signs should warn people... *“Do not enter the wash bay while the unit is washing a vehicle”*.

Jim Coleman Company has 12” x 12” signs available at no charge, if you will install them at the automatic bay. Please call (713) 683-9878 to order these important safety signs. Jim Coleman Company will provide two (2) safety signs at no cost (per automatic purchased). Please provide the serial number of the automatic purchased when ordering the signs. The part number of the safety signs is **#38442**.

Please call the parts department at (713) 683-9878 and order two (2) safety signs using part **#38442**.

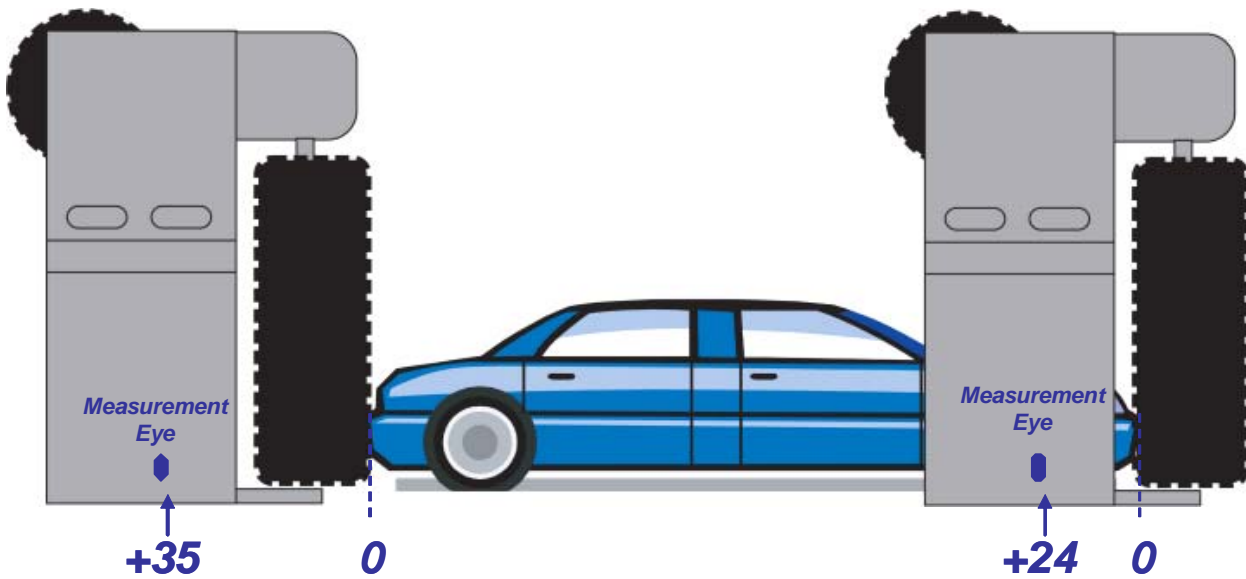
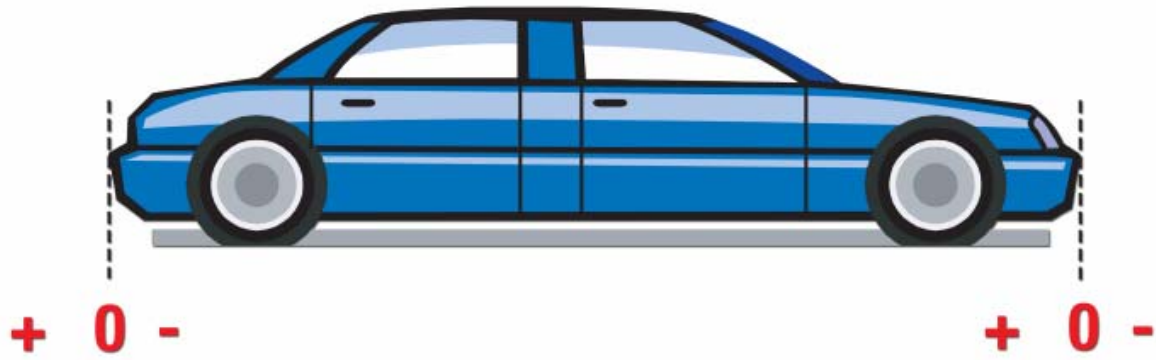

*Example Settings for  
Front & Rear Side Brush*

### ***Start and Stop Brush Positions***





# FusionX

## SYSTEM START-UP

### **Do Not Turn On Power Until Directed To Do So**

- Step 1 Flush incoming water line before filling the water tanks on the FusionX. Connect Water Line and fill. Rinse Tank. Check to make sure water is clean with no cloudy residue. If the water is cloudy or dirty, continue to flush lines.
- Step 2 Fill Concentrate Tank with quality chemicals. Turn on water at the hydrominder one at a time making sure chemical is drawn up into chemical tank. It is a good idea to allow the mixed chemical to go to drain until the hose from the concentrate tank is full.
- Step 3 Before installing the tips in the undercarriage bar and connecting the 1" high-pressure hose to the gantry, you need to flush the lines. To do this, follow the steps listed in the "Test Screen".
- Step 4 Turn on the air compressor and set to approximately 100 PSI. Adjust pressure on gantry mounted regulator to 100 PSI.
- Step 5 Turn off the Electrical Disconnect Switch on Gantry. Turn on Electrical Disconnect Switch on Electrical Control Center ("ECC") inside Equipment Room. The Operator Interface Panel should come on.
- Step 6 Press the F7 "Tech Menu" button and scroll to Test Function. Turn on Presoak for about 2-3 minutes to flush line and get product to the Gantry. Turn on Tire Cleaner for about two (2) minutes. Turn on High Pressure Soap to flush lines then turn off and connect 1" line in Top Solenoid Box. Continue to test services until you test all functions that apply to your machine. Modify low pressure applications by adjusting air pressure using the regulators inside the low pressure box.
- Step 7 Turn on the Manual Operation Toggle Switch located inside the Gantry Control Panel mounted on the Gantry. Turn on power at Electrical Disconnect Switch located on Gantry. Check the rotation of the drive motors by pressing the Gantry Reverse Switch. This should cause the unit to travel away from home position. If not, then have a qualified electrician change the incoming 3-phase power to correct rotation.



Press the Boom Down Switch and the Top Boom should lower. Use these manual buttons to test all the Gantry functions for proper operation. Also, use the buttons the check brush rotation and operation. **(SEE ROTATION CHARTS ON PAGES 17 & 18)**

Step 8 Move the unit up and down the track by pressing the Drive Forward and Drive Reverse switches. Make sure the Prox switches are set properly to read the Home and End of track targets. They should have approximately 3/8ths inch clearance.

Step 9 **INITIALIZING THE SYSTEM**

***THIS MUST BE DONE TO ENSURE PROPER OPERATION***

First, perform a "Wheel, Side Brush, Top Brush, and Boom Test". These tests can be accessed in the "F7 Tech Menu" of the Red Lion Interface Panel. This test will allow the PLC to store the correct length of travel for each of these components.

Next, you **MUST** save the Treadle position that is required for the wheel brush to locate vehicle front wheels. This setting is done in "F2 Adjust Gantry Counts". The best way to accomplish this is to park a vehicle on the treadle plate and with the gantry in manual mode, position the gantry until the wheel brushes are aligned with the exact center of the front wheels. Press the "Wheel Brush Extend" manual push button to confirm alignment. Now press "Save" on the Red Lion display to store this position.

**Assigning Recipes:** Assign the Recipes in "F1 Recipe Menu" that you wish to use. Factory recipes are listed in your manual for both combination and touchfree wash cycles.

**IMPORTANT: Brush No Load Tests**

1. Go to "F7-Tech Menu" on your Red Lion. Use the Raise key until you get to Menu Option 30 – "TB No Load Test" and press Enter. See the pictures below.
2. Now you need to switch the Gantry manual toggle switch "On" and **lower the Top Brush** about 18-24" to get the brush **out of the nest** then press the arrow under the display on the Red Lion, where it says "Test". The word "Off" will change to "Testing".
3. The Top Brush will begin to spin and you will see the "PV" value begin to change (PV = Present Value).
4. After about 8 seconds, you will see that the "NL" value has now been set (NL = No Load).



5. If the brush components are in good mechanical condition and **the brushes were not in contact with any surface**, the test is complete. You can now press the arrow under the display, where it says "Accept". The word "Off" will change to "Writing".
6. When the word "Off" returns under "Accept", this brush test is complete.
7. You can now press the "Prev" button then raise up to Menu Option 31 – LB No Load Test and Menu Option 32 – RB No Load Test and repeat the procedures above for each brush.
8. These procedures are required to calibrate the acceptable no load brush torque based on the incoming voltage at your site. **NOTE: These procedures will have to be repeated periodically to recalibrate acceptable no load torque after some time in service due to normal mechanical wear. It is recommended repeat at least once within the first 30 days of operation and as needed thereafter.**

```
Technician Menu
Raise/Lower selects..
Menu Option: 30
TB No Load Test
Enter Selects Option
```

```
TB No Load Torq
Capture NL torque
PU: 0.1 %
NL: 37.9 %
% NL - 99.9 %
Test Off Accept Off
```

```
Technician Menu
Raise/Lower selects..
Menu Option: 31
LB No Load Test
Enter Selects Option
```

```
LB No Load Torq
Capture NL torque
PU: 0.0 %
NL: 37.9 %
% NL -100.1 %
Test Off Accept Off
```

```
Technician Menu
Raise/Lower selects..
Menu Option: 32
RB No Load Test
Enter Selects Option
```

```
RB No Load Torq
Capture NL torque
PU: 0.0 %
NL: 44.1 %
% NL - 99.9 %
Test Off Accept Off
```





### **Site Data Settings**

Step 10 Press F5 and enter the "Owner" password. The default password is "1234". Then Press F8 and scroll through each option. Set each option to match your equipment. Example; if you have on-board blowers you must enter "Equipped". If no blowers or if the blowers are free standing, then select "Not equipped".

Scroll through the remaining screens and select the option that matches your equipment package.

Step 11 You are now ready to test the unit on a car. Pull vehicle into bay and place in park position with front wheel on stop station. Press the Cycle 1 button on the Electrical Panel and watch the FusionX go through the wash process. Check for leaks and correct as needed. Once completed, press cycle 2 Button and monitor wash process. Repeat the same procedure for Cycles 3 and 4. Only after washing several vehicles should you need to adjust the different chemicals that are being applied to the car.

Test the FusionX many times to ensure it is functioning properly.

Refer to "Brush Position Settings" beginning on Page 8 for adjustments to brush positions.

Check all Prox Switch settings to ensure there is a gap of at least 3/8".

Check all Proxes to ensure they are exactly square with their target.

### **Wheel Scrub Features and Set-up Instructions**

You will find a recipe bit titled "Wheel Brushes" in the Program Recipe menu. A custom recipe is required to apply this function to a wash recipe. You cannot perform the wheel brush step on the first pass of a wash recipe. The wheel brush photo eye must first find the rear wheel position.

#### **Air Pressure Adjustments**

There are two air regulators to move the brushes in and out, one of them to extend and one to retract. The extend regulator adjustment is very critical and should be adjusted to the lowest possible operating pressure, usually about 20 psi. Very little pressure is required to clean the vehicle wheels and too much air pressure could cause unnecessary load and wear on the wheel brush spindle gearmotors. The retract regulator should be adjusted so the brushes return smoothly but positively into their home position, usually about 30 psi.

#### **Timers**

There are also two timers and two counters associated with this option. Under "F2-Timers & Counters" on the Red Lion, go to the "Adjust Timers" menu (Menu Option 0) and press the "Enter" button until you see a timer called "Wheel Brush Dwell". This timer determines how long the brush will stay engaged in the wheel in each direction (clockwise & counter-clockwise). This is factory set to 3 seconds.



Press the “Next” button to advance to the “Wheel Brush Retract Dwell” timer. This timer determines how long the brush disengages from the wheel between direction changes. This timer is factory set to 1 second. You want the brushes to disengage the wheel slightly while it changes directions. If it does not, you would want to increase this timer value.

### **Counters**

Since we always know where the front tire will be because of the Treadle, we use that to our advantage. Under “F2-Timers & Counters”, go to “Adjust Gantry Counts” menu (Menu Option 1) and press the “Enter” button. There you will see an adjustable counter titled “Treadle Position”.

### **Setting Front Wheel Counter**

To set this counter, put the gantry in manual mode (turn toggle switch in gantry panel ‘on’), and manually position the gantry until the wheel brush is perfectly aligned with the center of the treadle eye. It is best if there is a vehicle parked properly on the treadle plate to achieve the best result. Manually extend the wheel brush to assure you are in the proper position using the manual push buttons for the Wheel Brush located in the gantry control panel.

Once you have achieved this position go back to the Red Lion and press the arrow key that is located directly below the center of the screen, below the word “Off” on the display. This word will then change to “On”. You will see the value under the word “Treadle” change. You have now set where the wheel brush will position at the front tire when the wheel brush function is performed in a wash recipe.

### **Setting Rear Wheel Counter**

The wheel brush photo eye will locate the rear wheel position in pass 1. This position is also adjustable. Watch it wash a variety of vehicles to determine if the rear wheel position should be adjusted.

If you determine that this adjustment must be done, Under “F2-Timers & Counters”, go to “Adjust Gantry Counts” menu (Menu Option 1) and press the “Enter” button. Now press the “Next” button repeatedly until you see a counter called “Rear Wheel Offset”.

If you need to adjust the rear wheel brush position closer to the front of the vehicle, you should decrease this counter. If you need to adjust the rear wheel brush position closer to the rear of the vehicle, you should increase this counter. The counters on the eFusion and the FusionX are incremented in inches. If the Wheel Brush always positions about 2 inches past the center of the rear wheels, you can decrease the counter setting by 2 inches.



## FusionX and eFusion

### ***Instructions for loading OMRON PLC and Red Lion memory module***

#### **SAVING EXISTING RECIPES and REVENUE (*Recipes and Revenue are stored in the PLC NOT the Red Lion*)**

1. With power on to the PLC, insert memory card into the slot in the PLC. Press the F5/Log In Page button and log in using the owner password. Press F6/Memory Card and select Recipe Mode then press Save Recipes twice. Remove the memory card with power still on. DO NOT CYCLE POWER ON & OFF.

#### **RED LION Operator Interface**

1. Turn off power to the display. Plug memory card into the slot located on the side of the Red Lion.
2. Turn on power to display. Wait for display to load program from memory card. (Observe text – LOADING CF). Once the screen is back to the main screen make sure the HMI number matches the version number you are loading.
3. After program is loaded, turn off power and remove card from display. Turn power back on.

#### **OMRON PLC (Loading Program Instructions)**

1. Turn off power to PLC. Open cover plate (located above the memory card slot) on CJ1G-CPU44 PLC module. Here you'll see 8 switches numbered 1-8 from top to bottom. Turn on DIP SW 7. (push switch to left position). Insert memory card into slot. Card is properly seated when the eject button is even with the top.
2. Turn on power to PLC. Wait for "busy" light to extinguish (about 5 to 10 seconds) and the main screen is up.
3. Turn off power to PLC. Remove memory card. Turn off DIP SW 7 (push switch to right position).
4. Turn on power to PLC.

#### **DOWNLOADING SAVED RECIPES**

1. With power on to the PLC, insert the memory card. Press the F5/Log In Page button and log in using the owner password. Press F6/Memory Card and select Recipe Mode then press Load Recipes twice.
2. Remove the memory card with power on. DO NOT CYCLE POWER ON & OFF



## FusionX Start Up Brush Position Settings

The following settings are based on the center line of the treadle eye being located 82 inches from the entrance end of the home prox target. Any variance in this dimension will require adjustments to the brush start positioners for proper operation.

These settings are located in the F2 Timers and Counters button on the Red Lion.

```
Timers & Counts
Raise/Lower selects..
Menu Option:  1
Adjust Gantry Cntr
Enter selects option
```

First set the wheel brush position for the front wheel. Since we always know the position of the front wheel, we can set this dimension as a fixed distance. Manually move the gantry to where the center of the wheel brush is at the center line of the eye on the treadle. Then press Enter. This will lock in this position for all wash cycles.

```
Treadle Position
Center wheel brushes
on centerline of
treadle. Press Enter
Gantry  Enter  Treadle
0.0    Off    34.5
```

This is the position of the high pressure wash boom as it washes the front of the vehicle. Decrease the number to move the gantry toward the exit end of the wash bay.

```
Start Boom
at front of car
Stop Gantry in front
of measurement eye...
- 12.5 "
```

This is the position of the high pressure wash boom as it washes the of the vehicle. Increase the number to move the gantry toward the entrance end of the wash bay.

A green screen with black text. The text reads: "Start Boom at rear of car", "Stop Gantry past the measurement eye ...", and "+ 40.0 "" in a black box at the bottom.

This screen sets the gantry position when the side brushes wash the front of the car. Decrease the number to move the brush closer to the exit end of the wash bay.

A green screen with black text. The text reads: "Front Brush Pass Position", "Stop Gantry in front of measurement eye...", and "+ 42.0 "" in a black box at the bottom.

This screen sets the gantry position when the side brushes wash the rear of the car. Increase the number to move the brush toward the entrance end of the wash bay.

A green screen with black text. The text reads: "Rear Brush Pass Position", "Stop Gantry relative to measurement eye...", and "+ 65.0 "" in a black box at the bottom.

This screen sets the gantry position at the front when the side brushes wash the sides of car. Decrease the number to start the side brushes more towards the exit end of the wash bay.

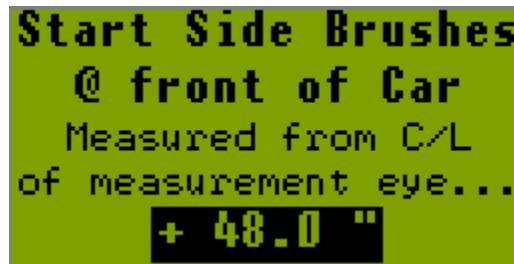
A green screen with black text. The text reads: "Start Side Brushes @ front of Car Measured from C/L of measurement eye... + 48.0 ""

This screen sets the gantry position at the rear when the side brushes wash the sides of car. Increase the number to start the side brushes more towards the entrance end of the wash bay.

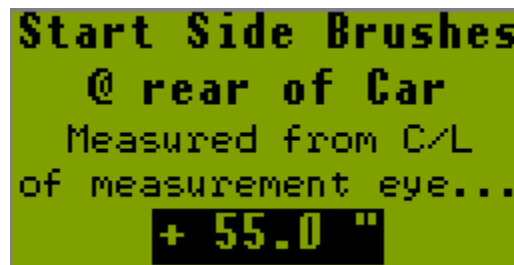
A green screen with black text. The text reads: "Start Side Brushes @ rear of Car Measured from C/L of measurement eye... + 55.0 ""

This screen sets the gantry position at the front where the top brush begins to wash the top of the car. Decrease the number to start the top brush more towards the exit end of the wash bay.

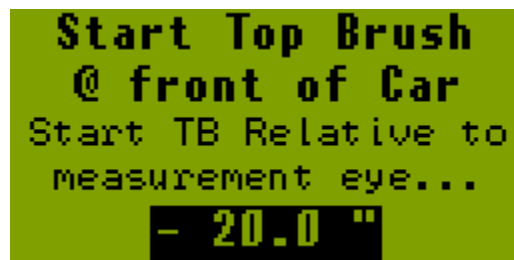
A green screen with black text. The text reads: "Start Top Brush @ front of Car Start TB Relative to measurement eye... - 20.0 ""

This screen sets the gantry position at the rear where the top brush begins to wash the top of the car. Increase the number to start the top brush more towards the entrance end of the wash bay.

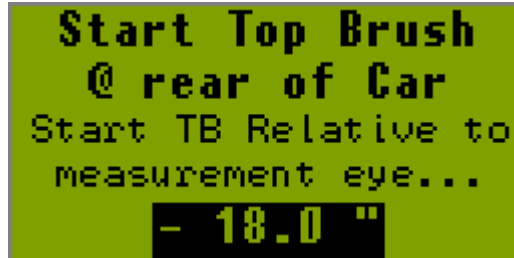
A green screen with black text. The text reads: "Start Top Brush @ rear of Car", "Start TB Relative to measurement eye...", and "- 18.0 "" in a black box at the bottom.

**Start Top Brush  
@ rear of Car**  
Start TB Relative to  
measurement eye...  
**- 18.0 ""**

This screen sets the gantry position for the Low Pressure Wax delivery at the vehicle front. Decrease the number to start the LP Wax more towards the exit end of the wash bay.

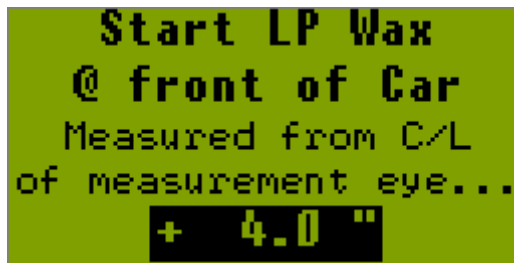
A green screen with black text. The text reads: "Start LP Wax @ front of Car", "Measured from C/L of measurement eye...", and "+ 4.0 "" in a black box at the bottom.

**Start LP Wax  
@ front of Car**  
Measured from C/L  
of measurement eye...  
**+ 4.0 ""**

This screen sets the gantry position for the Low Pressure Wax delivery at the vehicle rear. Increase the number to start the LP Wax more towards the entrance end of the wash bay.

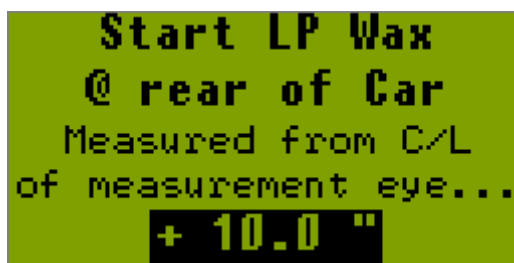
A green screen with black text. The text reads: "Start LP Wax @ rear of Car", "Measured from C/L of measurement eye...", and "+ 10.0 "" in a black box at the bottom.

**Start LP Wax  
@ rear of Car**  
Measured from C/L  
of measurement eye...  
**+ 10.0 ""**



This screen sets the gantry position for the Triple Shine Conditioner delivery at the vehicle front. Decrease the number to start the LP Wax more towards the exit end of the wash bay.

```
Start Triple Shine
@ front of Car
Measured from C/L
of measurement eye...
+ 22.0 "
```

This screen sets the gantry position for the Triple Shine Conditioner delivery at the vehicle rear. Increase the number to start the LP Wax more towards the entrance end of the wash bay.

```
Start Triple Shine
@ rear of Car
Measured from C/L
of measurement eye...
+ 30.0 "
```

This screen sets the gantry position for the Presoak delivery at the vehicle front. Decrease the number to start the Presoak more towards the exit end of the wash bay.

```
Start Presoak
@ front of Car
Measured from C/L
of measurement eye...
- 12.0 "
```

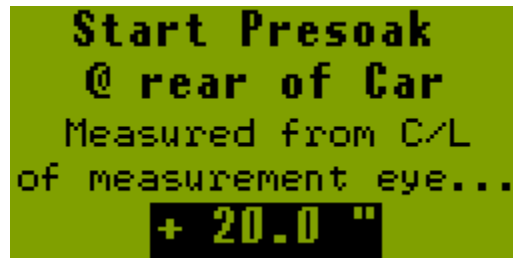

This screen sets the gantry position for the Presoak delivery at the vehicle rear. Increase the number to start the Presoak more towards the entrance end of the wash bay.

A green screen with black text. The text reads: "Start Presoak @ rear of Car", "Measured from C/L of measurement eye...", and "+ 20.0 "" in a black box at the bottom.

This screen sets the gantry position for the Rocker Panel Sprayers delivery at the vehicle front. Decrease the number to start the RPS more towards the exit end of the wash bay.

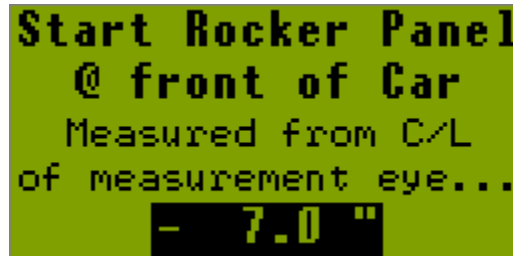
A green screen with black text. The text reads: "Start Rocker Panel @ front of Car", "Measured from C/L of measurement eye...", and "- 7.0 "" in a black box at the bottom.

This screen sets the gantry position for the Rocker Panel Sprayers delivery at the vehicle rear. Increase the number to start the RPS more towards the entrance end of the wash bay.

A green screen with black text. The text reads: "Start Rocker Panel @ rear of Car", "Measured from C/L of measurement eye...", and "+ 10.0 "" in a black box at the bottom.

This screen sets the gantry position for the HP Side Spray delivery at the vehicle front. Decrease the number to start the HP Side Spray more towards the exit end of the wash bay.

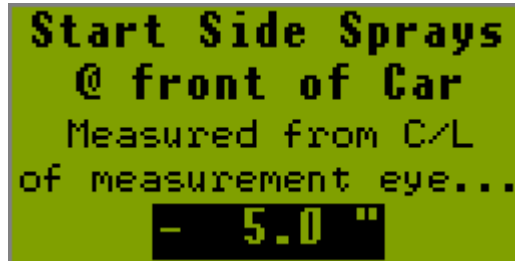
A green screen with black text. The text reads: "Start Side Sprays @ front of Car Measured from C/L of measurement eye... - 5.0 ""

This screen sets the gantry position for the HP Side Spray delivery at the vehicle rear. Increase the number to start the HP Side Spray more towards the entrance end of the wash bay.

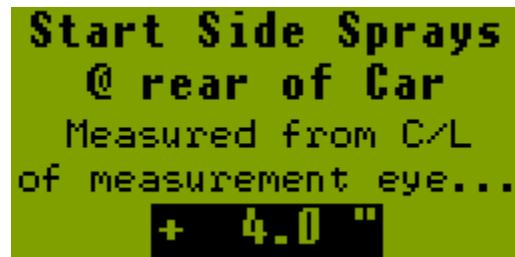
A green screen with black text. The text reads: "Start Side Sprays @ rear of Car Measured from C/L of measurement eye... + 4.0 ""

This screen sets the gantry position for the Tire Cleaner delivery at the vehicle front. Decrease the number to start the Tire Cleaner more towards the exit end of the wash bay.

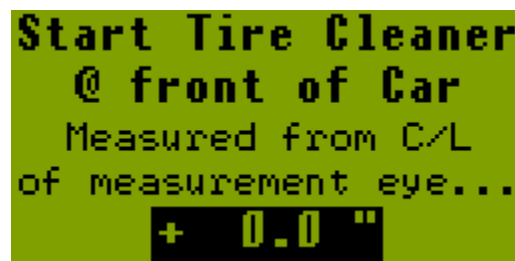
A green screen with black text. The text reads: "Start Tire Cleaner @ front of Car Measured from C/L of measurement eye... + 0.0 ""

This screen sets the gantry position for the Tire Cleaner delivery at the vehicle rear. Increase the number to start the Tire Cleaner more towards the entrance end of the wash bay.

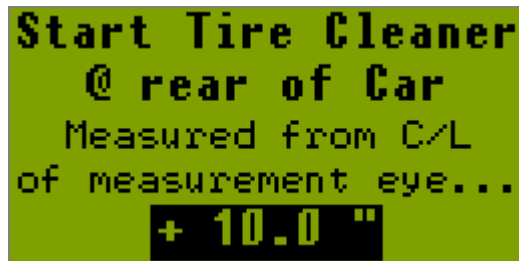
A screenshot of a green screen with black text. The text reads: "Start Tire Cleaner @ rear of Car", "Measured from C/L of measurement eye...", and "+ 10.0 "".

This screen sets the gantry position for the Side Brush Lube delivery at the vehicle front. Decrease the number to start the Side Brush Lube more towards the exit end of the wash bay.

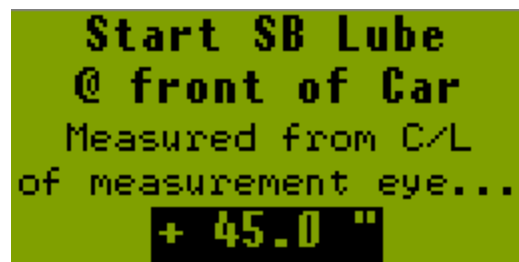
A screenshot of a green screen with black text. The text reads: "Start SB Lube @ front of Car", "Measured from C/L of measurement eye...", and "+ 45.0 "".

This screen sets the gantry position for the Side Brush Lube delivery at the vehicle rear. Increase the number to start the Side Brush Lube more towards the entrance end of the wash bay.

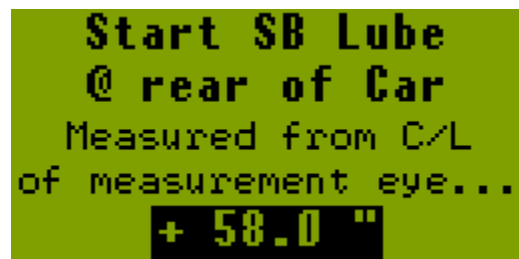
A screenshot of a green screen with black text. The text reads: "Start SB Lube @ rear of Car", "Measured from C/L of measurement eye...", and "+ 58.0 "".

This screen sets the gantry position for the Top Brush Lube delivery at the vehicle front. Decrease the number to start the Top Brush Lube more towards the exit end of the wash bay.

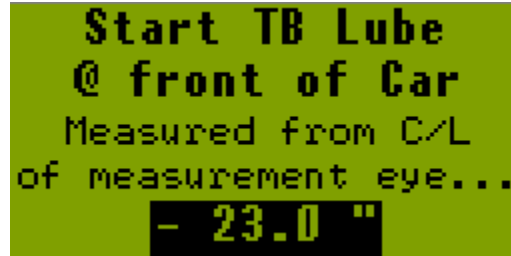
A green screen with black text. The text reads: "Start TB Lube @ front of Car", "Measured from C/L of measurement eye...", and "- 23.0 "".

This screen sets the gantry position for the Top Brush Lube delivery at the vehicle rear. Increase the number to start the Top Brush Lube more towards the entrance end of the wash bay.

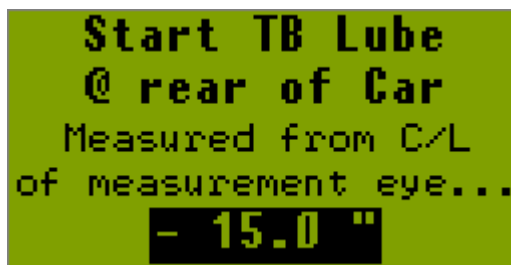
A green screen with black text. The text reads: "Start TB Lube @ rear of Car", "Measured from C/L of measurement eye...", and "- 15.0 "".

This screen sets the Top Brush Lower Limit at the rear of the vehicle. This is how far the top brush will lower during a rear brush pass that is accomplished with the top brush (when the side brushes cannot reach the rear of a long vehicle). The distance is counted from the Top Brush home position down.

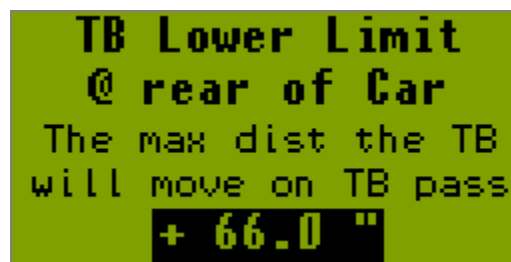
A green screen with black text. The text reads: "TB Lower Limit @ rear of Car", "The max dist the TB will move on TB pass", and "+ 66.0 "".

This screen adjusts the Wheel Brush position for the rear wheel only. The front wheels are set according to the treadle position. A negative number moves the wheel brush towards the exit end.

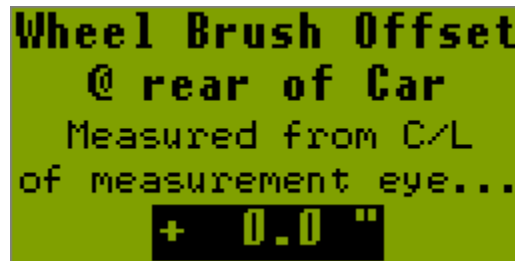

## Adjusting High Pressure Boom Travel and Dwell time Presets

To high boom must be programmed to go down at the front and rear of the car and for any time delay you wish to add. It is possible to lower and raise the boom at the start and the end of each wash pass. Complete travel is 86 counts. Set the boom to travel any number of counts from 0 to 86. To set this distance go to the Program Recipe screen and select the recipe you wish to program.



Press the triangle under modify recipe and press the triangle under modify each pass

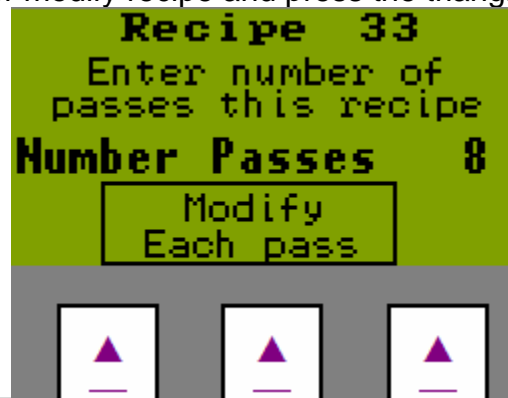

At the next screen you will have the choice to modify each the “Bits (Functions), Speeds and Presets for each pass. Select “Presets”

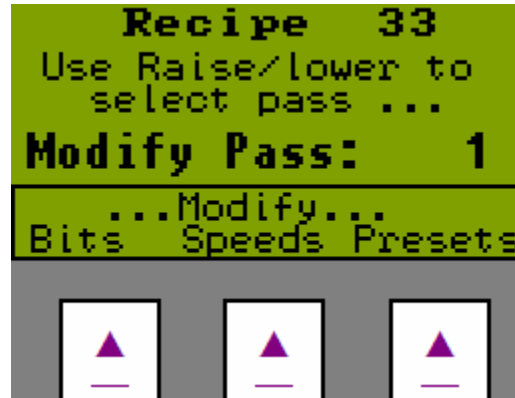

In the presets you'll be able to set the amount time delay at the beginning and end of each pass. You also set the distance the boom will travel down at the start and end of each pass. To add boom down to another pass press the triangle beneath either previous or next pass to select.

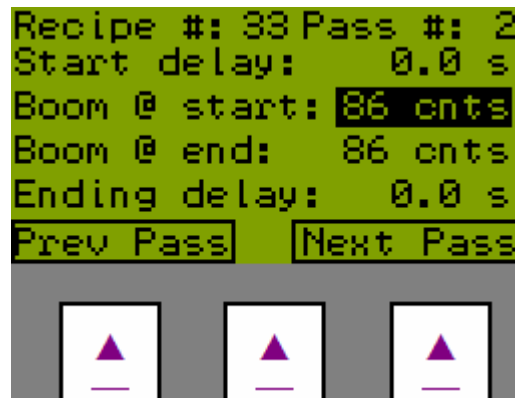

**EXIT END OF BAY**

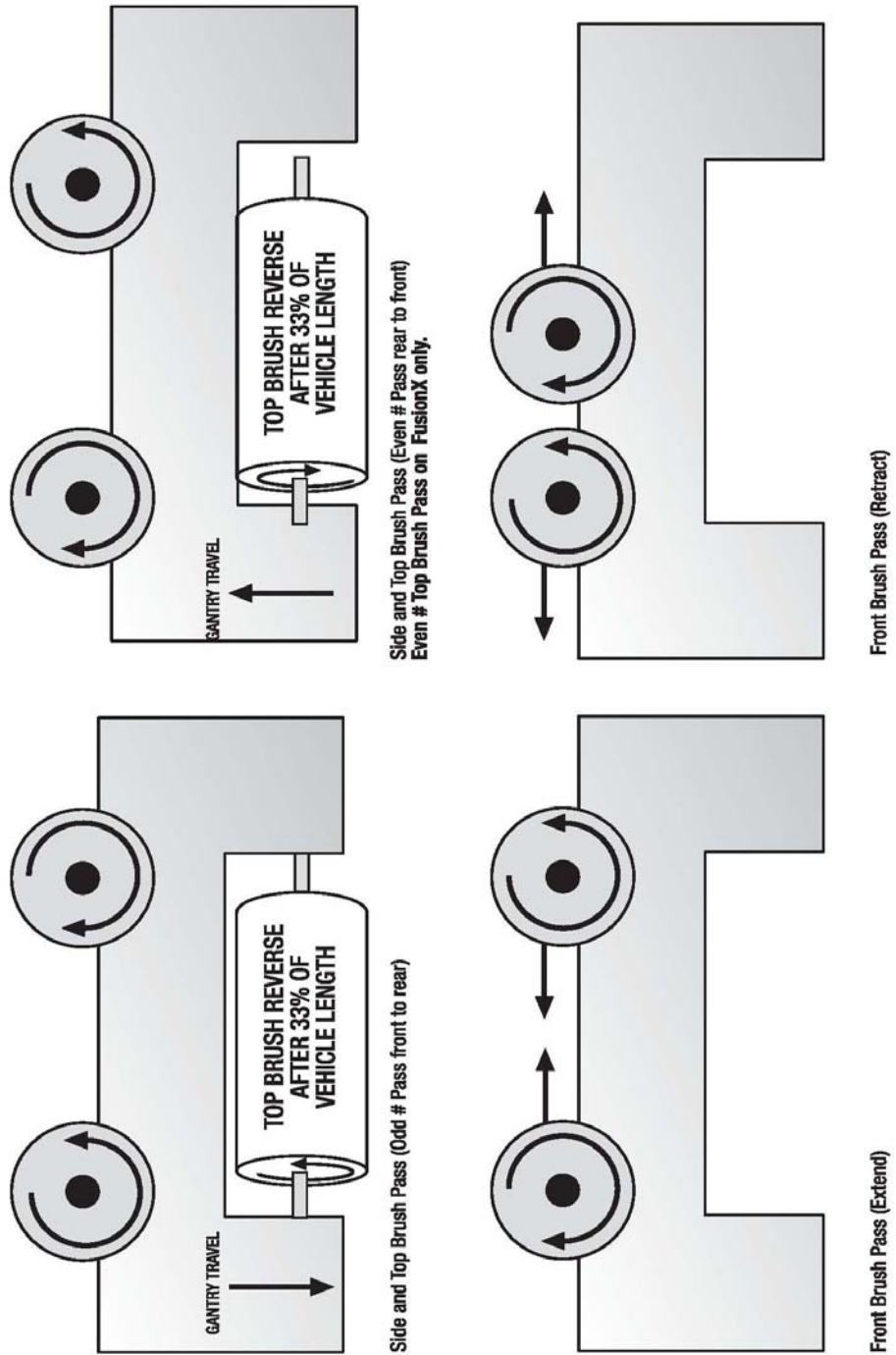

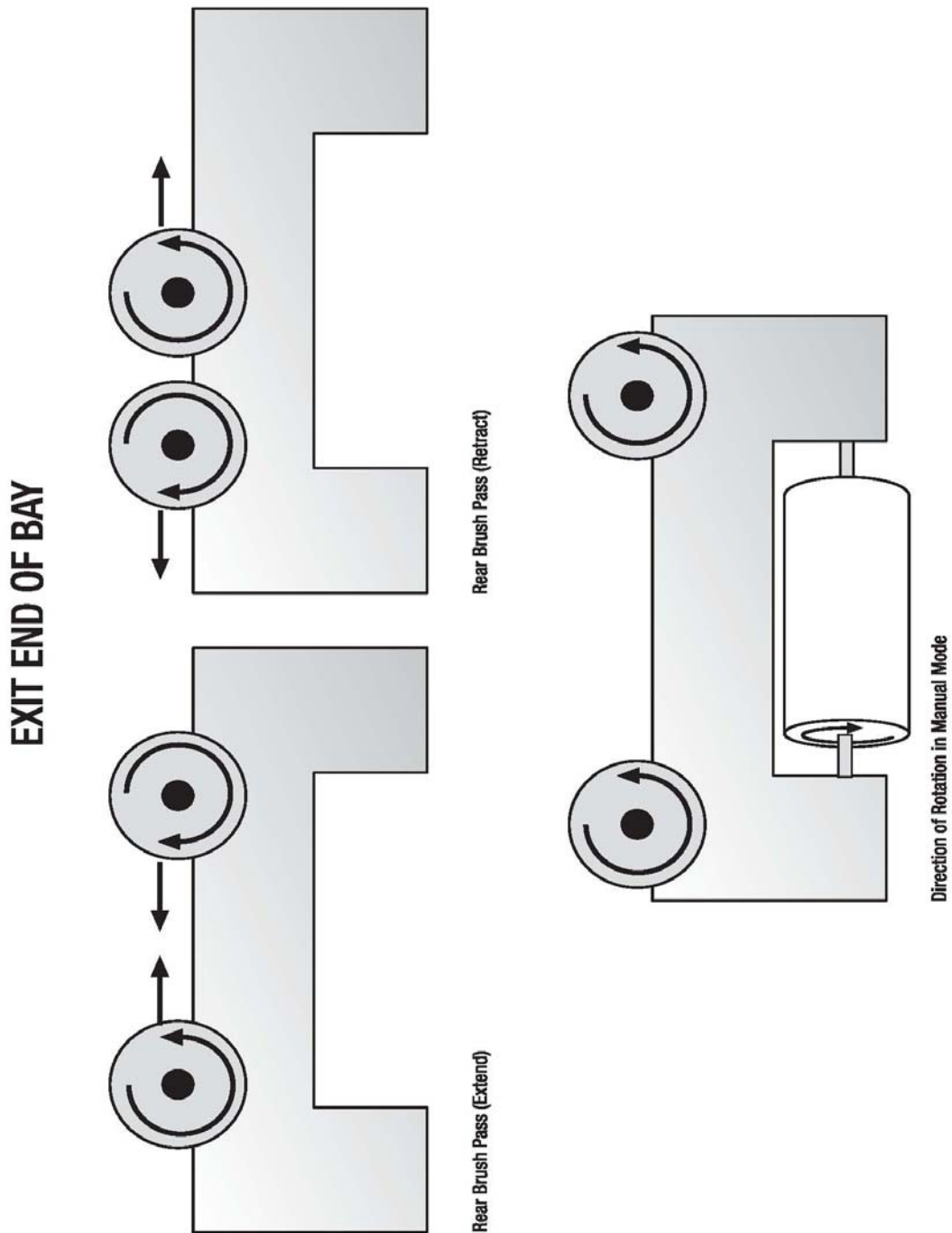





## **Safety Signs**

Jim Coleman Company recommends that you have **warning** or **safety signs** at the entrance and exit locations of the automatic wash bay. These signs should be mounted where they are visible from the Entrance and Exit locations of the wash bay. These warning signs should warn people... *"Do not enter the wash bay while the unit is washing a vehicle"*.

Jim Coleman Company has 12" x 12" signs available at no charge, if you will install them at the automatic bay. Please call (713) 683-9878 to order these important safety signs. Jim Coleman Company will provide two (2) safety signs at no cost (per automatic purchased). Please provide the serial number of the automatic purchased when ordering the signs. The part number of the safety signs is **#38442**.

Please call the parts department at (713) 683-9878 and order two (2) safety signs using part **#38442**.

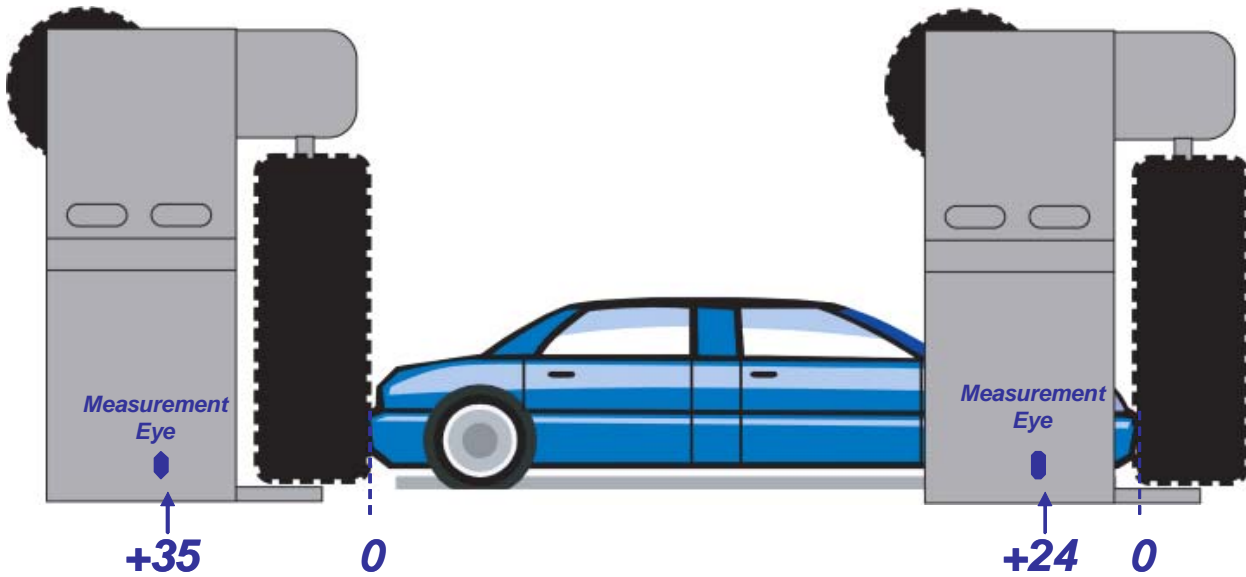
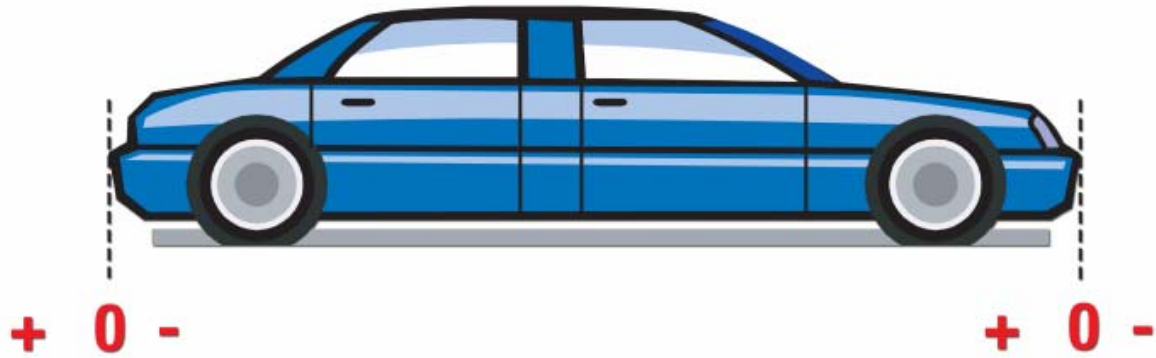

*Example Settings for  
Front & Rear Side Brush*

### ***Start and Stop Brush Positions***





## Fusion Gantry Counter Settings

The following chart outlines default brush and other gantry positioner settings. These settings determine where the brushes start and stop contact with the car. Refer to the drawings on page 8. Notice that the front and rear of the car is always "0" counts. A negative number moves the start/stop position toward the exit end of the bay. A positive number moves the start/stop position toward the entrance end of the bay. The counts are in inches. The distance is measured from where the measurement eye finds the front and rear of the car.

Red Lion Description	eFusion Default Settings	FusionX Default Settings	Red Lion Software Limits	
			Minimum Value	Maximum Value
Start Gantry (Boom, Fx) @ Front	(-12.5)	(-12.5)	-30.0	+0.0
Start Gantry (Boom, Fx) @ Rear	(+40.0)	(+40.0)	+20.0	+60.0
Front Brush Pass	(+17.0)	(+42.0)	+10.0	+50.0
Rear Brush Pass	(+44.0)	(+65.0)	+38.0	+75.0
Start Side Brushes @ Front	(+24.0)	(+48.0)	+15.0	+55.0
Start Side Brushes @ Rear	(+30.0)	(+55.0)	+25.0	+65.0
Start Top Brush @ Front	(-18.0)	(-20.0)	-30.0	+0.0
Start Top Brush @ Rear	(-26.0)	(-18.0)	-35.0	+0.0
Rear TB Pass on Long Vehicles	(-2.0)	(-20.0)	-30.0	+5.0
Start LP Wax @ Front	(+4.0)	(+4.0)	-20.0	+20.0
Start LP Wax @ Rear	(+10.0)	(+10.0)	-20.0	+20.0
Start Trifoam @ Front	(+0.0)	(+22.0)	-30.0	+30.0
Start Trifoam @ Rear	(+10.0)	(+30.0)	+0.0	+75.0
Start Presoak @ Front	(-12.0)	(-12.0)	-30.0	+0.0
Start Presoak @ Rear	(+16.0)	(+20.0)	+0.0	+75.0
Start Rocker Panel @ Front	(-7.0)	(-7.0)	-20.0	+10.0
Start Rocker Panel @ Rear	(+28.5)	(+10.0)	+0.0	+50.0
Start Side Sprays @ Front	(-15.0)	(-5.0)	-30.0	+10.0
Start Side Sprays @ Rear	(+25.0)	(+4.0)	-10.0	+50.0
Start TC (tire cleaner) @ Front	(-5.0)	(+0.0)	-20.0	+10.0
Start TC (tire cleaner) @ Rear	(-2.2)	(+10.0)	-20.0	+30.0
Start SB (side brush) Lube @ Front	(+21.0)	(+45.0)	+0.0	+75.0
Start SB (side brush) Lube @ Rear	(+33.0)	(+58.0)	+0.0	+75.0
Start TB (top brush) Lube @ Front	(-21.0)	(-23.0)	-50.0	+10.0
Start TB (top brush) Lube @ Rear	(-23.0)	(-15.0)	-50.0	+10.0
TB (top brush) Lower Limit @ Rear	(+66.0)	(+66.0)	+0.0	+70.0
Wheel Brush Offset @ Rear	(+0.0)	(+0.0)	-20.0	+20.0
Flip Blower @ Front	(+5.0)	(+5.0)	-50.0	+100.0
Flip Blower @ Rear	(+0.0)	(+0.0)	-50.0	+50.0
Presoak Overlap @ middle of car	+3.0	+3.0	+0.0	+20.0



# Fusion Gantry I-O Decals

## Channel 2208-2211

Gantry Analog Inputs 0-10v DC  
4 Point Input - SRT2-AD041

Vert.Sw all 'off' / Horiz.Sw 2,5,7 'on'

- V0+. Left Spindle Torque (AM)
- 0-. Left Spindle Torque (AC)
- V1+. Right Spindle Torque (AM)
- 1-. Right Spindle Torque (AC)
- V2+. Top Spindle Torque (AM)
- 2-. Top Spindle Torque (AC)
- V3+. Gantry Drive Torque (AM)
- 3-. Gantry Drive Torque (AC)

## Channel 2200-2201

Gantry Analog Outputs 0-10v DC  
2 Point Output - SRT2-DA021

Vert.Sw all 'off' / Horiz.Sw 2,5 'on'

- V0+. Left Brush Positioner (V+)
- 0-. Left Brush Positioner (AC)
- V1+. Right Brush Positioner (V+)
- 1-. Right Brush Positioner (AC)

## Channel 2202-2203

Gantry Analog Outputs 0-10v DC  
2 Point Output - SRT2-DA021

Vert.Sw 6 'on' / Horiz.Sw 2,5 'on'

- V0+. Top Brush Positioner (V+)
- 0-. Top Brush Positioner (AC)
- V1+. Gantry Drive (V+)
- 1-. Gantry Drive (AC)

## Channel 2008

Gantry Inputs - 24v DC(-)  
16 Point Input - SRT2-ID16  
Address 0

- 0. Measurement Eye, entrance side
- 1. L.Brush Encoder Prox1,inner
- 2. L.Brush Encoder Prox2,outer
- 3. R.Brush Encoder Prox1,inner
- 4. R.Brush Encoder Prox2,outer
- 5. T.Brush Encoder Prox1,lower
- 6. T.Brush Encoder Prox2,upper
- 7. Gantry Home Prox, exit
- 8. Gantry End oTrack Prox, entrance
- 9. Gantry Encoder Prox1, lower
- 10. Gantry Encoder Prox2, upper
- 11. Vacation Home Prox
- 12. Side Brush Center Limit Prox
- 13. Wheel Brush Eye
- 14.
- 15.

## Channel 2002

Gantry Outputs - 24vDC(-)  
16 Point Output - SRT2-OD16  
Address 4

- 0. Left Brush Extend
- 1. Left Brush Retract
- 2. Right Brush Extend
- 3. Right Brush Retract
- 4. Left Brush Spindle CW
- 5. Left Brush Spindle CCW
- 6. Right Brush Spindle CW
- 7. Right Brush Spindle CCW
- 8. Photo Sensors, Emitter (-)
- 9. Reset VFDs
- 10. Top Brush Up
- 11. Top Brush Down
- 12. Top Brush Spindle CW
- 13. Top Brush Spindle CCW
- 14. Gantry Drive Forward
- 15. Gantry Drive Reverse

## Channel 2009

Gantry Inputs - 24v DC(-)  
16 Point Input - SRT2-ID16  
Address 2

- 0. L.Brush Home Limit
- 1. L.Brush Extended Limit
- 2. R.Brush Home Limit
- 3. R.Brush Extended Limit
- 4. Top Brush Home Limit
- 5. Top Brush Lower Limit
- 6. Wheel Brushes Retract Prox
- 7. Gantry Drive Fault
- 8. Side Brush Drive Fault
- 9. Top Brush Drive Fault
- 10. Osc./ Wheel Brush Fault
- 11. Blower OL/Drive Fault
- 12. Blower Prox Fwd
- 13. Blower Prox Rev
- 14.
- 15.

## Channel 2001

Gantry Outputs -24vAC & 24vDC(-)  
16 Point Output - SRT2-ROC16  
Address 2

- 0. Top Spray Solenoid
- 1. Side Brush Lube, Fwd
- 2. Side Brush Lube, Rev
- 3. Top Brush Lube, Rev
- 4. Top Brush Lube, Fwd
- 5. Air Purge Solenoid
- 6. SB Tilt Solenoid (brushes vertical)
- 7. Spot Free Air Purge Sol.
- 8. Wheel Brush Air Solenoid
- 9. Wheel Brush Spin CW
- 10. Wheel Brush HP Solenoid
- 11. Wheel Brush Spin CCW
- 12. Scroll Sign A or Drive Fwd
- 13. Scroll Sign B or Stop
- 14. Scroll Sign C or Back Up
- 15. Scroll Sign D

## Channel 2010

Gantry Inputs - 24v DC(-)  
16 Point Input - SRT2-ID16  
Address 4

- 0. Jog Gantry Forward
- 1. Jog Gantry Reverse
- 2. Jog Boom Up
- 3. Jog Boom Down
- 4. Jog Oscillate Motor
- 5. Jog Boom Tilt Fwd
- 6. Jog Boom Tilt Rev
- 7. Jog Left Brush Extend
- 8. Jog Left Brush Retract
- 9. Jog Right Brush Extend
- 10. Jog Right Brush Retract
- 11. Jog Top Brush Up
- 12. Jog Top Brush Down
- 13. Jog Wheel Brush Extend
- 14. Jog Wheel Brush Spin
- 15. Manual Jog Enable

## Channel 2000

Gantry Outputs -24vAC & 24vDC(-)  
16 Point Output - SRT2-ROC16  
Address 0

- 0. Blower MS 1, Center
- 1. Blower Nozzle Osc CW
- 2. Blower MS 2, Left
- 3. Blower Nozzle Osc CCW
- 4. Rocker Panel Solenoid
- 5. PreSoak Sol.1, reverse
- 6. PreSoak Sol.2, forward
- 7. Tire Cleaner Solenoid
- 8. Tri Color Foam Solenoid
- 9. Side Spray Solenoid
- 10. LP Wax & Glass.Treat Solenoid
- 11. Blower MS 3, Right
- 12.
- 13.
- 14.
- 15.

## FusionX Only

### Channel 2011

Gantry Inputs - 24v DC(-)  
16 Point Input - SRT2-ID16

Address 6

0. Can Eye, exit side of boom
1. Boom Safety, Rear, exit side
2. Boom Safety, Front, entrance side
3. Boom Encoder Prox1, lower
4. Boom Encoder Prox2, upper
5. Boom Home Limit
6. Boom Lower Limit
7. Boom Belt Safety
8. Contour Eye 1, top
9. Contour Eye 2, 2nd
10. Contour Eye 3, 3rd
11. Contour Eye 4, bottom
12. Boom Drive Fault
- 13.
- 14.
- 15.

### Channel 2003

Gantry Outputs -24vAC & 24vDC(-)  
8 Point Output - SRT2-ROC08

Address 6

0. Boom Up
1. Boom Down
2. Oscillator VFD
- 3.
4. Tilt Boom, Front
5. Tilt Boom, Rear
- 6.
7. Water Dump Valve, Boom

## Fusion ECC I-O Decals

### Channel 2005

ECC Outputs -24vAC & 24vDC(-)  
16 Point Output - SRT2-ROC16

#### Address 10

0. HP Wash
1. HP Wax
2. UnderCarriage Sol.
3. Med Press Sol
4. Spot Free MS
5. Hi pH PreSoak MS
6. Tire Cleaner MS
7. PreSoak Heater
8. Tri Foam MS
9. Reclaim Water Sol.
10. PreSoak Hi pH Recirc Sol
11. Lo pH PreSoak MS
12. Photo Sensor Test Relay
13. PreSoak Lo pH Recirc Sol.
14. Auto Cashier Reset, 24vDC
15. Blower Count-down Timer

### Channel 2014

ECC Inputs - 24v DC(-)  
16 Point Input - SRT2-ID16

#### Address 12

0. Treadle Switch
1. Exit Door Eye
2. E-stop Sw
3. Reset Sw
4. UnderCarriage Eye
5. Door T'stat
6. Freeze T'stat
7. Tire Cleaner Level OK
8. Wax Level OK
9. Cashier Cycle1
10. Cashier Cycle2
11. Cashier Cycle3
12. Cashier Cycle4
13. PreSoak Level OK
14. H2O Level OK
- 15.

### Channel 2006

ECC Outputs -24vAC & 24vDC  
16 Point Output - SRT2-ROC16

#### Address 12

0. Enter Now Light
1. LP Wax MS
2. Please Wait Light
3. Cold Water Sol.
4. Sol 1 Tri Foam
5. Sol 2 Tri Foam
6. Sol 3 Tri Foam
7. InTank Water Heater
8. Brush Lube MS
9. Ext.Blower Nozzle CW
10. Ext.Blower MS 2&3
11. Ext.Blower Nozzle C CW
12. Alarm Horn
13. Pump Main or Rinse Sol.
14. Ext.Blower MS 1, center
15. Auto Cashier Reset, 120vAC

### Channel 2015

ECC Inputs - 24v DC(-)  
16 Point Input - SRT2-ID16

#### Address 14

0. Manual Cycle 1
1. Manual Cycle 2
2. Manual Cycle 3
3. Manual Cycle 4
4. Bill Changer 1 Fault
5. Bill Changer 2 Fault
6. Auto Cashier Fault
7. Exit Door Prox, vacation only
8. Reclaim Tank Level OK
9. Ext.Blower Nozzle Prox
- 10.
11. Ext.Blower Eye (early shut-off)
- 12.
- 13.
14. 3ph Power Detection
15. 25hp Overload Tripped



## Fusion

### Opt'I Channel 2004

ECC Outputs - Dry Contacts & 24vAC

8 Point Output - SRT2-ROC08

Address 8

0. Open Entry Door
1. Open Exit Door
2. Close Entry Door
3. Close Exit Door
- 4.
5. Tire Glaze MS
6. Tire Glaze LiquidSol
7. Tire Glaze Air Cyl Sol

## Fusion

### Opt'I Channel 2027

ECC Outputs - 24vAC Neutral

8 Point Output - SRT2-ROC08

Address 14 (on Analog Comm)

0. Scroll Sign A
1. Scroll Sign B
2. Scroll Sign C
3. Scroll Sign D
- 4.
- 5.
- 6.
- 7.

## Fusion

### Opt'I Channel 2007

ECC Outputs - 120vAC

16 Point Output - SRT2-ZOC16

Address 14

0. Stop Light
1. Enter Light
2. Backup Light
3. Presoak Light
4. Rocker Panel Light
5. Clearcoat Light
6. Tri Foam Light
7. Spot Free Light
8. Exit Light
9. Clean Car Light
10. Please Wait Light
11. LP Wax Light
- 12.
- 13.
- 14.
- 15.



## SETTING PARAMETERS ON YASKAWA J1000 VF DRIVES

Due to the expanded capabilities of the Yaskawa J1000 VFDs, the complete parameter list is much more extensive. Most of the additional parameters have a default setting that will work in our applications which limits the parameters you will need to set. See the drawing on page 2 for pictorial instructions.

To set the drive, press the down arrow button once on the Yaskawa J1000 and the “Par” message will be displayed. Now press the “ENTER” button and “A1-01” will be displayed. The J1000 allows you to set each digit individually, instead of scrolling up or down through the entire range to reach the value, as the J7 VFD did. Use the up and down arrows to raise or lower each digit to the desired value. Press the “>RESET” button to advance to the next digit from left to right and change as necessary. When the desired parameter number is reached, press the “ENTER” button to view the parameter value. Use the up and down arrows to raise or lower each digit to the desired value. Press the “>RESET” button to advance to the next digit from left to right and change as necessary. When the desired value is set, press the “ENTER” button to return to the parameter list. Repeat these same procedures for each required parameter. The order in which you enter these settings must be exactly as they are listed on the parameter lists. Once you have completed setting all of the parameters for the VFD, press the “ESC” button until you have returned to the run mode. What is seen on the display will be different on certain drives based on the settings that you entered. If you set “b1-01” to a value of “0”, the display would show the set frequency, such as “F 60.00”. If you were not required to set “b1-01”, the display would show “F 0.00”

**IMPORTANT NOTE:**

*IF YOU ARE ONLY REVIEWING THE SETTINGS, **DO NOT REVIEW “A1-03”** OR ALL SETTINGS WILL BE RESET TO YASKAWA FACTORY DEFAULTS WHICH WILL REQUIRE YOU TO RE-ENTER ALL SETTINGS.*



**\*\*\* IMPORTANT \*\*\***

If only reviewing settings, **DO NOT REVIEW A1-03 on the any of the J1000 VFDs (or n01 on the J7 VFDs).** This will reset all settings to the VFD manufacturer's factory defaults and you would have to re-enter all settings.

eFusion - VFD Parameters						
Parameters for Gantry Drive Motor VFD						
NEW STYLE Yaskawa J1000 Drive		Parameter Descriptions	OLD STYLE Yaskawa or Omron J7 Drive			
A1-03	to	2220	2-wire init	n01	to	10
C1-01	to	0.5	Accel 1	n16	to	1.0
C1-02	to	0.5	Decel 1	n17	to	1.0
d1-01	to	55.0	Freq. Ref.1	n21	to	55.0
E1-04	to	75.0	Max Freq.	n09	to	75.0
H1-04	to	4	Input S4=Spd.Ref.A	n38	to	6
H1-03	to	14	S3 = External Reset			
H4-01	to	103	Monitor Current Output			
L1-01	to	2	O/L Protect	n33	to	1
L2-01	to	2	Pwr.Loss Ride Thru=Indefinite	n47	to	2
L5-01	to	2	# auto restarts=6	n48	to	6

## Access Parameter Menu and Change Parameter Value

J1000 Digital Operator power-up state →



Press the  key once.

The digital operator shows the parameter menu (PAR) then press the  key.

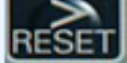

Select Parameter Menu

Press the  key to select the digit you would like to change. Next use the

 and  keys to select the

parameter group, sub-group or number

Modify the parameter value using the

 and  key and press

the  key to save the new value.



Select Parameter



Change Parameter Value



eFusion - VFD Parameters					
Parameters for Top Brush Spindle Motor VFD					
NEW STYLE Yaskawa J1000 Drive		Parameter Descriptions		OLD STYLE Yaskawa or Omron J7 Drive	
A1-03	to 2220		2-wire init	n01	to 10
b1-01	to 0		Freq Reference = d1-01	n03	to 1
C1-01	to 0.8		Accel 1	n16	to 0.8
C1-02	to 1.5		Decel 1	n17	to 1.5
d1-01	to 55.0		Freq. Ref.1	n21	to 55.0
H1-04	to 4		Input S4=Spd.Ref.A	n38	to 6
H1-03	to 14		S3 = External Reset		
H4-01	to 103		Monitor Current Output		
L1-01	to 2		O/L Protect	n33	to 1
L2-01	to 2		Pwr.Loss Ride Thru=Indefinite	n47	to 2
L5-01	to 2		# auto restarts=6	n48	to 6

eFusion - VFD Parameters					
Parameters for Top Brush Positioner Motor VFD					
NEW STYLE Yaskawa J1000 Drive		Parameter Descriptions		OLD STYLE Yaskawa or Omron J7 Drive	
A1-03	to 2220		2-wire init	n01	to 10
b2-04	to 2.0		DC Inj. @ Stop	n53	to 5.0
C1-01	to 1.1		Accel 1	n16	to 1.1
C1-02	to 0.8		Decel 1	n17	to 0.8
H1-04	to 4		Input S4=Spd.Ref.A	n38	to 6
H1-03	to 14		S3 = External Reset		
L1-01	to 2		O/L Protect	n33	to 1
L2-01	to 2		Pwr.Loss Ride Thru=Indefinite	n47	to 2
L5-01	to 2		# auto restarts=6	n48	to 6



eFusion - VFD Parameters					
Parameters for Right Brush Spindle Motor VFD					
NEW STYLE Yaskawa J1000 Drive		Parameter Descriptions	OLD STYLE Yaskawa or Omron J7 Drive		
A1-03	to 2220	2-wire init	n01	to 10	
b1-01	to 0	Freq Reference = d1-01	n03	to 1	
C1-01	to 0.8	Accel 1	n16	to 0.8	
C1-02	to 1.5	Decel 1	n17	to 1.5	
d1-01	to 55.0	Freq. Ref.1	n21	to 55.0	
H1-04	to 4	Input S4=Spd.Ref.A	n38	to 6	
H1-03	to 14	S3 = External Reset			
H4-01	to 103	Monitor Current Output			
L1-01	to 2	O/L Protect	n33	to 1	
L2-01	to 2	Pwr.Loss Ride Thru=Indefinite	n47	to 2	
L5-01	to 2	# auto restarts=6	n48	to 6	

eFusion - VFD Parameters					
Parameters for Left Brush Spindle Motor VFD					
NEW STYLE Yaskawa J1000 Drive		Parameter Descriptions	OLD STYLE Yaskawa or Omron J7 Drive		
A1-03	to 2220	2-wire init	n01	to 10	
b1-01	to 0	Freq Reference = d1-01	n03	to 1	
C1-01	to 0.8	Accel 1	n16	to 0.8	
C1-02	to 1.5	Decel 1	n17	to 1.5	
d1-01	to 55.0	Freq. Ref.1	n21	to 55.0	
H1-04	to 4	Input S4=Spd.Ref.A	n38	to 6	
H1-03	to 14	S3 = External Reset			
H4-01	to 103	Monitor Current Output			
L1-01	to 2	O/L Protect	n33	to 1	
L2-01	to 2	Pwr.Loss Ride Thru=Indefinite	n47	to 2	
L5-01	to 2	# auto restarts=6	n48	to 6	



eFusion - VFD Parameters					
Parameters for Right Brush Positioner Motor VFD					
NEW STYLE Yaskawa J1000 Drive		Parameter Descriptions	OLD STYLE Yaskawa or Omron J7 Drive		
A1-03	to	2220	2-wire init	n01	to 10
b2-04	to	1.0	DC Inj. @ Stop	n53	to 1.0
C1-01	to	1.0	Accel 1	n16	to 1.0
C1-02	to	1.0	Decel 1	n17	to 1.0
<b>H1-04</b>	to	<b>4</b>	Input S4=Spd.Ref.A	n38	to 6
H1-03	to	14	S3 = External Reset		
H3-03	to	30	Ana.Freq.Ref.Gain	n41	to 30
L1-01	to	2	O/L Protect	n33	to 1
L2-01	to	2	Pwr.Loss Ride Thru=Indefinite	n47	to 2
L5-01	to	2	# auto restarts=6	n48	to 6

eFusion - VFD Parameters					
Parameters for Left Brush Positioner Motor VFD					
NEW STYLE Yaskawa J1000 Drive		Parameter Descriptions	OLD STYLE Yaskawa or Omron J7 Drive		
A1-03	to	2220	2-wire init	n01	to 10
b2-04	to	1.0	DC Inj. @ Stop	n53	to 1.0
C1-01	to	1.0	Accel 1	n16	to 1.0
C1-02	to	1.0	Decel 1	n17	to 1.0
<b>H1-04</b>	to	<b>4</b>	Input S4=Spd.Ref.A	n38	to 6
H1-03	to	14	S3 = External Reset		
H3-03	to	30	Ana.Freq.Ref.Gain	n41	to 30
L1-01	to	2	O/L Protect	n33	to 1
L2-01	to	2	Pwr.Loss Ride Thru=Indefinite	n47	to 2
L5-01	to	2	# auto restarts=6	n48	to 6



eFusion - VFD Parameters					
Parameters for Wheel Brush Spindle Motor VFD					
NEW STYLE Yaskawa J1000 Drive		Parameter Descriptions		OLD STYLE Yaskawa or Omron J7 Drive	
A1-03	to 2220	2-wire init		n01	to 10
b1-01	to 0	Freq Reference = d1-01		n03	to 1
C1-01	to 0.5	Accel 1		n16	to 0.4
C1-02	to 0.5	Decel 1		n17	to 1.0
d1-01	to 60.0	Freq. Ref.1		n21	to 60.0 - 70.0**
E1-04	to 70.0	Max Freq.		n09	to 70

<b>For 380 - 415 volt Applications ONLY</b>					
E1-05	to 230	Volt.Max (for 380-415v)		n10	to 230
E1-08	to 12	Volt.Mid (for 380-415v)		n13	to 12
E1-10	to 12	Volt.Min (for 380-415v)		n15	to 12
E2-01	to 4.0	Mtr. Rated Current (for 380-415v)		n32	to 4.0
H1-04	to 4	Input S4=Spd.Ref.A		n38	to 6
H1-03	to 14	S3 = External Reset			
L1-01	to 0	O/L Protect		n33	to 2
L2-01	to 2	Pwr.Loss Ride Thru=Indefinite		n47	to 2
L5-01	to 2	# auto restarts=6		n48	to 6

eFusion - VFD Parameters					
Parameters for Blower Oscillator Motor VFD					
NEW STYLE Yaskawa J1000 Drive		Parameter Descriptions		OLD STYLE Yaskawa or Omron J7 Drive	
A1-03	to 2220	2-wire init		n01	to 10
b1-01	to 0	Freq Reference = d1-01		n03	to 1
C1-01	to 0.4	Accel 1		n16	to 0.4
C1-02	to 0.4	Decel 1		n17	to 0.4
d1-01	to 15.0	Freq. Ref.1		n21	to 15.0
H1-04	to 4	Input S4=Spd.Ref.A		n38	to 6
H1-03	to 14	S3 = External Reset			
L1-01	to 2	O/L Protect		n33	to 1
L2-01	to 2	Pwr.Loss Ride Thru=Indefinite		n47	to 2
L5-01	to 2	# auto restarts=6		n48	to 6





**\*\*\* IMPORTANT \*\*\***

If only reviewing settings, **DO NOT REVIEW A1-03 on the any of the J1000 VFDs (or n01 on the J7 VFDs).** This will reset all settings to the VFD manufacturer's factory defaults and you would have to re-enter all settings.

FusionX - VFD Parameters						
Parameters for Gantry Drive Motor VFD						
NEW STYLE Yaskawa J1000 Drive			Parameter Descriptions	OLD STYLE Yaskawa or Omron J7 Drive		
A1-03	to	2220	2-wire init	n01	to	10
C1-01	to	0.5	Accel 1	n16	to	1.0
C1-02	to	0.5	Decel 1	n17	to	1.0
d1-01	to	55.0	Freq. Ref.1	n21	to	55.0
E1-04	to	75.0	Max Freq.	n09	to	75.0
H1-04	to	4	Input S4=Spd.Ref.A	n38	to	6
H1-03	to	14	S3 = External Reset			
H4-01	to	103	Monitor Current Output			
L1-01	to	2	O/L Protect	n33	to	1
L2-01	to	2	Pwr.Loss Ride Thru=Indefinite	n47	to	2
L5-01	to	2	# auto restarts=6	n48	to	6



FusionX - VFD Parameters					
Parameters for Oscillator Motor VFD					
NEW STYLE Yaskawa J1000 Drive		Parameter Descriptions	OLD STYLE Yaskawa or Omron J7 Drive		
A1-03	to 2220	2-wire init	n01	to 10	
b1-01	to 0	Freq Reference = d1-01	n03	to 1	
C1-01	to 1.0	Accel 1	n16	to 1.0	
C1-02	to 1.0	Decel 1	n17	to 1.0	
d1-01	to 42.0	Freq. Ref.1	n21	to 42.0	
H1-04	to 4	Input S4=Spd.Ref.A	n38	to 6	
H1-03	to 14	S3 = External Reset			
L1-01	to 2	O/L Protect	n33	to 1	
L2-01	to 2	Pwr.Loss Ride Thru=Indefinite	n47	to 2	
L5-01	to 2	# auto restarts=6	n48	to 6	

FusionX - VFD Parameters					
Parameters for Wash Boom Motor VFD					
NEW STYLE Yaskawa J1000 Drive		Parameter Descriptions	OLD STYLE Yaskawa or Omron J7 Drive		
A1-03	to 2220	2-wire init	n01	to 10	
b1-01	to 0	Freq Reference = d1-01	n03	to 1	
b2-04	to 2.0	DC Inj.@ Stop	n53	to 5.0	
C1-01	to 0.5	Accel 1	n16	to 1.0	
C1-02	to 0.4	Decel 1	n17	to 1.0	
d1-01	to 60.0	Freq. Ref.1	n21	to 60.0	
H1-04	to 4	Input S4=Spd.Ref.A	n38	to 6	
H1-03	to 14	S3 = External Reset			
L1-01	to 2	O/L Protect	n33	to 1	
L2-01	to 2	Pwr.Loss Ride Thru=Indefinite	n47	to 2	
L3-04	to 4	Decel Stall Prev. = Overexcit Decel			
L5-01	to 2	# auto restarts in 10min=2	n48	to 6	
n3-13	to 1.30	Overexcit Decel Gain (up to 1.40)			



FusionX - VFD Parameters					
Parameters for Top Brush Spindle Motor VFD					
NEW STYLE Yaskawa J1000 Drive		Parameter Descriptions	OLD STYLE Yaskawa or Omron J7 Drive		
A1-03	to 2220	2-wire init	n01	to 10	
b1-01	to 0	Freq Reference = d1-01	n03	to 1	
C1-01	to 0.8	Accel 1	n16	to 0.8	
C1-02	to 1.5	Decel 1	n17	to 1.5	
d1-01	to 55.0	Freq. Ref.1	n21	to 55.0	
H1-04	to 4	Input S4=Spd.Ref.A	n38	to 6	
H1-03	to 14	S3 = External Reset			
H4-01	to 103	Monitor Current Output			
L1-01	to 2	O/L Protect	n33	to 1	
L2-01	to 2	Pwr.Loss Ride Thru=Indefinite	n47	to 2	
L5-01	to 2	# auto restarts=6	n48	to 6	

FusionX - VFD Parameters					
Parameters for Top Brush Positioner Motor VFD					
NEW STYLE Yaskawa J1000 Drive		Parameter Descriptions	OLD STYLE Yaskawa or Omron J7 Drive		
A1-03	to 2220	2-wire init	n01	to 10	
b2-04	to 2.0	DC Inj.@ Stop	n53	to 5.0	
C1-01	to 1.1	Accel 1	n16	to 1.1	
C1-02	to 0.8	Decel 1	n17	to 0.8	
H1-04	to 4	Input S4=Spd.Ref.A	n38	to 6	
H1-03	to 14	S3 = External Reset			
L1-01	to 2	O/L Protect	n33	to 1	
L2-01	to 2	Pwr.Loss Ride Thru=Indefinite	n47	to 2	
L5-01	to 2	# auto restarts=6	n48	to 6	



FusionX - VFD Parameters					
Parameters for Right Brush Spindle Motor VFD					
NEW STYLE Yaskawa J1000 Drive		Parameter Descriptions	OLD STYLE Yaskawa or Omron J7 Drive		
A1-03	to 2220	2-wire init	n01	to 10	
b1-01	to 0	Freq Reference = d1-01	n03	to 1	
C1-01	to 0.8	Accel 1	n16	to 0.8	
C1-02	to 1.5	Decel 1	n17	to 1.5	
d1-01	to 55.0	Freq. Ref.1	n21	to 55.0	
H1-04	to 4	Input S4=Spd.Ref.A	n38	to 6	
H1-03	to 14	S3 = External Reset			
H4-01	to 103	Monitor Current Output			
L1-01	to 2	O/L Protect	n33	to 1	
L2-01	to 2	Pwr.Loss Ride Thru=Indefinite	n47	to 2	
L5-01	to 2	# auto restarts=6	n48	to 6	

FusionX - VFD Parameters					
Parameters for Left Brush Spindle Motor VFD					
NEW STYLE Yaskawa J1000 Drive		Parameter Descriptions	OLD STYLE Yaskawa or Omron J7 Drive		
A1-03	to 2220	2-wire init	n01	to 10	
b1-01	to 0	Freq Reference = d1-01	n03	to 1	
C1-01	to 0.8	Accel 1	n16	to 0.8	
C1-02	to 1.5	Decel 1	n17	to 1.5	
d1-01	to 55.0	Freq. Ref.1	n21	to 55.0	
H1-04	to 4	Input S4=Spd.Ref.A	n38	to 6	
H1-03	to 14	S3 = External Reset			
H4-01	to 103	Monitor Current Output			
L1-01	to 2	O/L Protect	n33	to 1	
L2-01	to 2	Pwr.Loss Ride Thru=Indefinite	n47	to 2	
L5-01	to 2	# auto restarts=6	n48	to 6	



FusionX - VFD Parameters					
Parameters for Right Brush Positioner Motor VFD					
NEW STYLE Yaskawa J1000 Drive		Parameter Descriptions	OLD STYLE Yaskawa or Omron J7 Drive		
A1-03	to 2220	2-wire init	n01	to	10
b2-04	to 1.0	DC Inj. @ Stop	n53	to	1.0
C1-01	to 1.0	Accel 1	n16	to	1.0
C1-02	to 1.0	Decel 1	n17	to	1.0
H1-04	to 4	Input S4=Spd.Ref.A	n38	to	6
H1-03	to 14	S3 = External Reset			
H3-03	to 30	Ana.Freq.Ref.Gain	n41	to	30
L1-01	to 2	O/L Protect	n33	to	1
L2-01	to 2	Pwr.Loss Ride Thru=Indefinite	n47	to	2
L5-01	to 2	# auto restarts=6	n48	to	6

FusionX - VFD Parameters					
Parameters for Left Brush Positioner Motor VFD					
NEW STYLE Yaskawa J1000 Drive		Parameter Descriptions	OLD STYLE Yaskawa or Omron J7 Drive		
A1-03	to 2220	2-wire init	n01	to	10
b2-04	to 1.0	DC Inj. @ Stop	n53	to	1.0
C1-01	to 1.0	Accel 1	n16	to	1.0
C1-02	to 1.0	Decel 1	n17	to	1.0
H1-04	to 4	Input S4=Spd.Ref.A	n38	to	6
H1-03	to 14	S3 = External Reset			
H3-03	to 30	Ana.Freq.Ref.Gain	n41	to	30
L1-01	to 2	O/L Protect	n33	to	1
L2-01	to 2	Pwr.Loss Ride Thru=Indefinite	n47	to	2
L5-01	to 2	# auto restarts=6	n48	to	6



FusionX - VFD Parameters					
Parameters for Wheel Brush Spindle Motor VFD					
NEW STYLE Yaskawa J1000 Drive		Parameter Descriptions		OLD STYLE Yaskawa or Omron J7 Drive	
A1-03	to	2220	2-wire init	n01	to 10
b1-01	to	0	Freq Reference = d1-01	n03	to 1
C1-01	to	0.5	Accel 1	n16	to 0.4
C1-02	to	0.5	Decel 1	n17	to 1.0
d1-01	to	60.0	Freq. Ref.1	n21	to 60.0 - 70.0**
E1-04	to	70.0	Max Freq.	n09	to 70

<b>For 380 - 415 volt Applications ONLY</b>					
E1-05	to	230	Volt.Max (for 380-415v)	n10	to 230
E1-08	to	12	Volt.Mid (for 380-415v)	n13	to 12
E1-10	to	12	Volt.Min (for 380-415v)	n15	to 12
E2-01	to	4.0	Mtr. Rated Current (for 380-415v)	n32	to 4.0
H1-04	to	4	Input S4=Spd.Ref.A	n38	to 6
H1-03	to	14	S3 = External Reset		
L1-01	to	0	O/L Protect	n33	to 2
L2-01	to	2	Pwr.Loss Ride Thru=Indefinite	n47	to 2
L5-01	to	2	# auto restarts=6	n48	to 6

FusionX - VFD Parameters					
Parameters for Blower Oscillator Motor VFD					
NEW STYLE Yaskawa J1000 Drive		Parameter Descriptions		OLD STYLE Yaskawa or Omron J7 Drive	
A1-03	to	2220	2-wire init	n01	to 10
b1-01	to	0	Freq Reference = d1-01	n03	to 1
C1-01	to	0.4	Accel 1	n16	to 0.4
C1-02	to	0.4	Decel 1	n17	to 0.4
d1-01	to	15.0	Freq. Ref.1	n21	to 15.0
H1-04	to	4	Input S4=Spd.Ref.A	n38	to 6
H1-03	to	14	S3 = External Reset		
L1-01	to	2	O/L Protect	n33	to 1
L2-01	to	2	Pwr.Loss Ride Thru=Indefinite	n47	to 2
L5-01	to	2	# auto restarts=6	n48	to 6





## FUSION ALARMS LISTING

Alarm	Description	Stored	Limiting Factors
1	no motion detected on gantry when drive enabled	user	OS
2	3x lockout alarm	user	OS
3	exit door open alarm if doors enabled this wash	perm	advisory
4	wheel B phase prox failure	user	OS
5	wheel A phase prox failure	user	OS
6	motion detected when drives are stopped	user	advisory
7	car measurement too small	user	terminate wash, 3x lockout OS
8	car measurement too large	user	terminate wash, 3x lockout OS
9	drive motor ran too long	user	terminate wash, OS if gantry doesn't return home.
10	boom failed to clear top LS. Rewind the top boom for equivalent time period.	user	limit boom function
11	boom prox A failure	user	limit boom function
12	boom prox B failure	user	limit boom function
13	no downward motion detected on boom.	user	limit boom function
14	no upward motion detected on boom when drive running	user	OS, if boom doesn't return home
15	motion detected when boom drive not running	user	limit boom function
16	boom watchdog, too long to move to SP	user	limit boom function
17	when profiling to rear of car, boom safety eyes sensed obstruction	perm	limit boom function
18	when profiling to front of car, boom safety eyes sensed obstruction	perm	limit boom function
19	rear boom cycle, boom safety eyes saw obstruction	perm	limit boom function
20	front boom cycle, boom safety eyes saw obstruction.	perm	limit boom function
21	rear boom cycle, measurement eye sensed obstruction	perm	limit boom function
22	front boom cycle, measurement eye obstructed	perm	limit boom function
23	rear boom cycle, can safety eye sensed obstruction.	perm	limit boom function
24	front boom cycle, can eye sensed an obstruction	perm	limit boom function
25	top prox was ON even though boom count greater than 10 counts.	user	run boom to 0 count
27	Treadle senses car even though wash was idle for > 12 minutes.	perm	advisory
28	Recipe called for undercarriage wash, but car was not detected by entrance eye	perm	advisory
29	jog enable switch left on for longer than 15 minutes	user	OS, when in jog mode
30	one or more manual jog switches left on for longer than 1 minute	user	advisory
31	e-stop switch on	user	OS
32	Reset switch left on for longer than 1 minute.	user	OS
33	one or more start wash switches left on for longer than 60 seconds	user	advisory
34	bill cashier 1 or 2 faulted	user	advisory
35	Auto-Cashier faulted	user	advisory
36	Tire Cleaner low level warning if low longer than 10 seconds	user	advisory
37	Wax low level warning if low for longer than 10 seconds	user	advisory





38	H2O low level warning and out of service if low for longer than 10 seconds	user	OS, after wash in progress completes
39	PreSoak low level warning and out of service if low for longer than 10 seconds	user	OS, after wash in progress completes
40	Gantry OL tripped	user	OS, if vfd doesn't reset
41	Boom OL tripped	user	OS, if vfd doesn't reset and boom can't return home
42	Osc OL tripped	user	no oscillation if vfd doesn't reset
43	advisory - reset button pressed	perm	advisory
44	Side Brush OL tripped	user	OS if brush cannot return home
45	blower nozzle proxies failed to show motion within 5 seconds of starting rotation VFD	perm	advisory
46	Home Prox Abnormal	user	advisory, other alarms may result limiting operation
47	gantry end of travel prox abnormal	user	advisory, other alarms may result limiting operation
48	Run track test before allowing auto cycles to begin	user	advisory
49	overspeed, gantry encoder	user	advisory
50	track test failed	user	advisory
51	treadle hung at end of wash cycle - reset wash after watchdog timer expires	perm	advisory
52	end of car not found during measurement pass	user	advisory
53	Customer did not leave treadle within 90 seconds	perm	advisory
54	13 minute max wash time exceeded. Cancel remaining wash cycle	user	terminate wash
55	treadle switch was on when car wash was started.	perm	advisory
56	car took too long to reach treadle after starting wash	perm	advisory
57	car off treadle for too long while wash in progress. Cancel remaining wash cycle.	user	terminate wash
58	customer failed to leave wash within 3 minutes after wash was completed.	perm	advisory
59	track test OK	user	advisory
60	top boom prox was not ON at start of wash. Do not allow wash to continue.	user	OS
61	Gantry home sensor was not on at start of wash. Do not allow wash to continue	user	OS
62	bottom boom prox ON at start of boom cycle. No boom cycle will result.	perm	limit boom function
63	main pump > 500 hours operation.	user	advisory
64	Pump OL tripped	user	OS
65	no car seen within 36"	user	terminate wash
66	while wash idle, gantry home prox was OFF for > 60 seconds. OS	user	OS
67	while wash idle, top boom prox was OFF for > 60 seconds; OS	user	OS
68	front boom pass, home prox sensed	perm	limit boom function
69	end of track prox sensed on rear boom pass	perm	limit boom function



70	left side brushes - encoder wiring backwards	user	limit brush function
71	right side brushes - encoder wiring backwards	user	limit brush function
72	top brushes - encoder wiring backwards	user	limit brush function
73	wash cycle attempted with job enable switch ON	user	OS when in jog mode
76	Relay for Gantry Eyes test sequence appears abnormal. All eyes were OFF at start of test.	user	OS
77	Relay for control panel eye tests sequence is abnormal. All eyes were OFF at start of test.	user	advisory
78	boom switches are miswired - counts backwards	user	limit boom function
79	gantry count prox switches miswired. Gantry encoder counting backwards	user	OS
80	Profile 1 did not test OFF at start of wash	user	limit boom function
81	Profile 2 did not test OFF at start of wash	user	limit boom function
82	Profile 3 did not test OFF at start of wash	user	limit boom function
83	Profile 4 did not test OFF at start of wash	user	limit boom function
84	Measurement eye did not test OFF at start of wasy	user	OS
85	can eye did not test OFF at start of wash	user	limit boom function
86	rear boom safety eye did not test OFF at start of wash	user	limit boom function
87	front boom safety eye did not test OFF at start of wash	user	limit boom function
88	treadle sensor did not test OFF at start of wash	user	advisory
89	undercarriage eye did not test OFF at start of wash	perm	advisory
90	Exit eye did not test ON at start of wash	perm	advisory
91	WB photo eye not OFF at start of wash	user	
92	TB OL detected	user	limit brush function
93	SB OL detected	user	limit brush function
94	TB no motion detected	user	limit brush function
96	Profile 1 photo (top) was not ON at start of wash	perm	limit boom function
97	Profile 2 photo was not ON at start of wash	perm	limit boom function
98	Profile 3 photo was not ON at start of wash	perm	limit boom function
99	Profile 4 photo was not ON at start of wash	perm	limit boom function
100	Measurement photo was not ON at start of wash cycle	perm	limit boom function
101	Can Eye was not ON at start of wash cycle	perm	limit boom function
102	Rear Boom Safety was not ON at start of wash, 2010.11	perm	limit boom function
103	Front Boom Safety was not ON at start of wash	perm	limit boom function
104	Treadle Eye was not ON at start of wash cycle	perm	advisory
105	UnderCar Eye was not ON at start of wash cycle	perm	advisory
106	exit eye was not ON at start of wash	perm	advisory
107	WB eye not ON at start of wash cycle	user	
108	boom belt safety prox alarm	user	
109	boom prox detected slack in belt	user	
110	pipe rack mode selected this wash	perm	
111	3-phase power fault	user	
112	reclaim water is low level	user	limit solenoid
113	blower tripped out	user	requires manual OL reset for blowers to operate
114	LB no load detected	user	limit brush function
115	RB no load detected	user	limit brush function



116	TB no load detected	user	limit brush function
117	TB home prox not sensed	user	OS
118	LB home prox not sensed	user	OS
119	RB home prox not sensed	user	OS
120	Boom home prox not sensed	user	OS
121	RB no motion detected	user	
122	WB home prox did not test ON at start of wash.	user	
123	Wheel Brush Photo was OFF at the start of wash	user	advisory
124	WB cycle not home	user	
125	gantry EOT prox did not sense at end of track	perm	advisory
126	TB motor current <b>too high</b>	<b>PERM</b>	limit brush function
127	TB motor current too low	USER	OS, Requires Manual Reset
128	wheel brushes did not return home. Terminate wash. Gantry will not move. OS if brushes don't return home	USER	OS, if brushes don't return home
129	center limit prox on brushes defective	USER	limit brush function
130	LB low torque alarm	USER	OS, Requires Manual Reset
131	LB <b>high</b> torque alarm	<b>PERM</b>	advisory
132	RB low torque alarm	USER	OS, Requires Manual Reset
133	RB <b>high</b> torque alarm	<b>PERM</b>	advisory
134	TB lower prox EOT alarm	USER	limit brush function
135	Network Comms Error - Loss or Error in Network Communication occurred	USER	OS

# ***Fusion Alarm Listing***

Nov. 2009

<b>Alarm</b>	<b>Description</b>	<b>Stored</b>	<b>Limiting Factors</b>
1	no motion detected on gantry when drive enabled	user	OS
2	3x lockout alarm	user	OS
3	exit door open alarm if doors enabled this wash	perm	advisory
4	wheel B phase prox failure	user	OS
5	wheel A phase prox failure	user	OS
6	motion detected when drives are stopped	user	advisory
7	car measurement too small	user	terminate wash, 3x lockout OS
8	car measurement too large	user	terminate wash, 3x lockout OS
9	drive motor ran too long	user	terminate wash, OS if gantry doesn't return home.

Alarm	Description	Stored	Limiting Factors
10	boom failed to clear top LS. Rewind the top boom for equivalent time period.	user	limit boom function
11	boom prox A failure	user	limit boom function
12	boom prox B failure	user	limit boom function
13	no downward motion detected on boom.	user	limit boom function
14	no upward motion detected on boom when drive running	user	OS, if boom doesn't return home
15	motion detected when boom drive not running	user	limit boom function
16	boom watchdog, too long to move to SP	user	limit boom function
17	when profiling to rear of car, boom safety eyes sensed obstruction	perm	limit boom function
18	when profiling to front of car, boom safety eyes sensed obstruction	perm	limit boom function

Alarm	Description	Stored	Limiting Factors
19	rear boom cycle, boom safety eyes saw obstruction	perm	limit boom function
20	front boom cycle, boom safety eyes saw obstruction.	perm	limit boom function
21	rear boom cycle, measurement eye sensed obstruction	perm	limit boom function
22	front boom cycle, measurement eye obstructed	perm	limit boom function
23	rear boom cycle, can safety eye sensed obstruction.	perm	limit boom function
24	front boom cycle, can eye sensed an obstruction	perm	limit boom function
25	top prox was ON even though boom count greater than 10 counts.	user	run boom to 0 count
27	Treadle senses car even though wash was idle for > 12 minutes.	perm	advisory
28	Recipe called for undercarriage wash, but car was not detected by entrance eye	perm	advisory
29	jog enable switch left on for longer than 15 minutes	user	OS, when in jog mode
30	one or more manual jog switches left on for longer than 1 minute	user	advisory
31	e-stop switch on	user	OS
32	Reset switch left on for longer than 1 minute.	user	OS
33	one or more start wash switches left on for longer than 60 seconds	user	advisory
34	bill cashier 1 or 2 faulted	user	advisory
35	Auto-Cashier faulted	user	advisory

Alarm	Description	Stored	Limiting Factors
36	Tire Cleaner low level warning if low longer than 10 seconds	user	advisory
37	Wax low level warning if low for longer than 10 seconds	user	advisory
38	H2O low level warning and out of service if low for longer than 10 seconds	user	OS, after wash in progress completes
39	PreSoak low level warning and out of service if low for longer than 10 seconds	user	OS, after wash in progress completes
40	Gantry OL tripped	user	OS, if vfd doesn't reset
41	Boom OL tripped	user	OS, if vfd doesn't reset and boom can't return home
42	Osc OL tripped	user	no oscillation if vfd doesn't reset
43	advisory - reset button pressed	perm	advisory
44	Side Brush OL tripped	user	OS if brush cannot return home
45	blowernozzle proxes failed to show motion within 5 seconds of starting rotation VFD	perm	advisory

Alarm	Description	Stored	Limiting Factors
46	Home Prox Abnormal	user	advisory, other alarms may result limiting operation
47	gantry end of travel prox abnormal	user	advisory, other alarms may result limiting operation
48	Run track test before allowing auto cycles to begin	user	advisory
49	overspeed, gantry encoder	user	advisory
50	track test failed	user	advisory
51	treadle hung at end of wash cycle - reset wash after watchdog timer expires	perm	advisory
52	end of car not found during measurement pass	user	advisory
53	Customer did not leave treadle within 90 seconds	perm	advisory
54	13 minute max wash time exceeded. Cancel remaining wash cycle	user	terminate wash
55	treadle switch was on when car wash was started.	perm	advisory
56	car took too long to reach treadle after starting wash	perm	advisory
57	car off treadle for too long while wash in progress. Cancel remaining wash cycle.	user	terminate wash
58	customer failed to leave wash within 3 minutes after wash was completed.	perm	advisory
59	track test OK	user	advisory



Alarm	Description	Stored	Limiting Factors
60	top boom prox was not ON at start of wash. Do not allow wash to continue.	user	OS
61	Gantry home sensor was not on at start of wash. Do not allow wash to continue	user	OS
62	bottom boom prox ON at start of boom cycle. No boom cycle will result.	perm	limit boom function
63	main pump > 500 hours operation.	user	advisory
64	Pump OL tripped	user	OS
65	no car seen within 36"	user	terminate wash
66	while wash idle, ganry home prox was OFF for > 60 seconds. OS	user	OS
67	while wash wash idle,top boom prox was OFF for > 60 seconds; OS	user	OS
68	front boom pass, home prox sensed	perm	limit boom function
69	end of track prox sensed on rear boom pass	perm	limit boom function

Alarm	Description	Stored	Limiting Factors
70	left side brushes - encoder wiring backwards	user	limit brush function
71	right side brushes - encoder wiring backwards	user	limit brush function
72	top brushes - encoder wiring backwards	user	limit brush function
73	wash cycle attempted with job enable switch ON	user	OS when in jog mode
76	Relay for Gantry Eyes test sequence appears abnormal. All eyes were OFF at start of test.	user	OS
77	Relay for control panel eye tests sequence is abnormal. All eyes were OFF at start of test.	user	advisory
78	boom switches are miswired - counts backwards	user	limit boom function
79	gantry count prox switches miswired. Gantry encoder counting backwards	user	OS
80	Profile 1 did not test OFF at start of wash	user	limit boom function
81	Profile 2 did not test OFF at start of wash	user	limit boom function

Alarm	Description	Stored	Limiting Factors
82	Profile 3 did not test OFF at start of wash	user	limit boom function
83	Profile 4 did not test OFF at start of wash	user	limit boom function
84	Measurement eye did not test OFF at start of wash	user	OS
85	can eye did not test OFF at start of wash	user	limit boom function
86	rear boom safety eye did not test OFF at start of wash	user	limit boom function
87	front boom safety eye did not test OFF at start of wash	user	limit boom function
88	treadle sensor did not test OFF at start of wash	user	advisory
89	undercarriage eye did not test OFF at start of wash	perm	advisory
90	Exit eye did not test ON at start of wash	perm	advisory
91	WB photo eye not OFF at start of wash	user	
92	TB OL detected	user	limit brush function
93	SB OL detected	user	limit brush function
94	TB no motion detected	user	limit brush function

Alarm	Description	Stored	Limiting Factors
96	Profile 1 photo (top) was not ON at start of wash	perm	limit boom function
97	Profile 2 photo was not ON at start of wash	perm	limit boom function
98	Profile 3 photo was not ON at start of wash	perm	limit boom function
99	Profile 4 photo was not ON at start of wash	perm	limit boom function
100	Measurement photo was not ON at start of wash cycle	perm	limit boom function
101	Can Eye was not ON at start of wash cycle	perm	limit boom function
102	Rear Boom Safety was not ON at start of wash, 2010.11	perm	limit boom function
103	Front Boom Safety was not ON at start of wash	perm	limit boom function
104	Treadle Eye was not ON at start of wash cycle	perm	advisory
105	UnderCar Eye was not ON at start of wash cycle	perm	advisory
106	exit eye was not ON at start of wash	perm	advisory
107	WB eye not ON at start of wash cycle	user	
108	boom belt safety prox alarm	user	
109	boom prox detected slack in belt	user	
110	pipe rack mode selected this wash	perm	
111	3-phase power fault	user	

Alarm	Description	Stored	Limiting Factors
112	reclaim water is low level	user	limit solenoid
113	blower tripped out	user	requires manual OL reset for blowers to operate
114	LB no load detected	user	limit brush function
115	RB no load detected	user	limit brush function
116	TB no load detected	user	limit brush function
117	TB home prox not sensed	user	OS
118	LB home prox not sensed	user	OS
119	RB home prox not sensed	user	OS
120	Boom home prox not sensed	user	OS

Alarm	Description	Stored	Limiting Factors
121	RB no motion detected	user	
122	WB home prox did not test ON at start of wash.	user	
123	Wheel Brush Photo was OFF at the start of wash	user	advisory
124	WB cycle not home	user	
125	gantry EOT prox did not sense at end of track	perm	advisory
126	TB motor current <b>too high</b>	<b>PERM</b>	limit brush function
127	TB motor current too low	USER	OS, Requires Manual Reset
128	wheel brushes did not return home. Terminate wash. Gantry will not move. OS if brushes don't return home	USER	OS, if brushes don't return home
129	center limit prox on brushes defective	USER	limit brush function

Alarm	Description	Stored	Limiting Factors
130	LB low torque alarm	USER	OS, Requires Manual Reset
131	LB <b>high</b> torque alarm	PERM	advisory
132	RB low torque alarm	USER	OS, Requires Manual Reset
133	RB <b>high</b> torque alarm	PERM	advisory
134	TB lower prox EOT alarm	USER	limit brush function
135	Network Comms Error - Loss or Error in Network Communication occurred	USER	OS

**Bedienungsanleitung  
User's Manual  
Notice Technique**

**Pneumatische Dosierpumpe II  
Pneumatic Metering Pump II  
Pompe Doseuse Pneumatique II**





## 1 General

This technical manual contains all the necessary instructions for the installation, start-up, maintenance and repair of the pneumatic metering pump.

**The safety instructions and pointers must always be observed!**

### Scope of guarantee:

The manufacturer only accepts the guarantee with regard to the operating safety, reliability and capacity of the metering pump under the following conditions:

- Assembly, connection, adjustment, maintenance and repairs are carried out by authorized, qualified personnel.
- The metering device is used in accordance with the instructions in the technical manual.
- Only **original spare parts** are used for repairs.
- If the pump casing is opened, then the guarantee will become void.

### 1.1 Safety instructions

During maintenance and repair work on parts which come into contact with cleaning products, and when replacing the bindings, the prescribed **protective clothing** (protective glasses, protective gloves, apron) must be worn because of the danger of irritation.

Only **original spare parts** must be used for repairs.

## 1.2 Pointers

In this manual, the **CAUTION**, **ATTENTION** and **NOTE** pointers have the following meanings:

**CAUTION:** This heading is used if imprecise or non-adherence to operating instructions, work instructions, prescribed work procedures and the like can lead to injury or accident.

**ATTENTION:** This heading is used if imprecise or non-adherence to operating instructions, work instructions, prescribed work procedures and the like can lead to the device being damaged.

**NOTE:** This heading is used if a special feature is being pointed out.

## 2 Description of pump functions

### 2.1 Pump model without integrated solenoid valve

The metering pump is pneumatically activated via an external 3/2-way solenoid control. The piston (2) is moved with the PTFE-coated diaphragm (4) against the return spring (3) to the metering stroke. The suction stroke is caused by the return spring (3).

The pump heads are equipped with double spherical valves (pos. 5) for the suction and pressure lines, as well as with a separate venting lever (pos. 6) with return line connection (pos. 7). The metering capacity of the pump can be mechanically adjusted during operation by means of stroke adjuster (pos. 8).

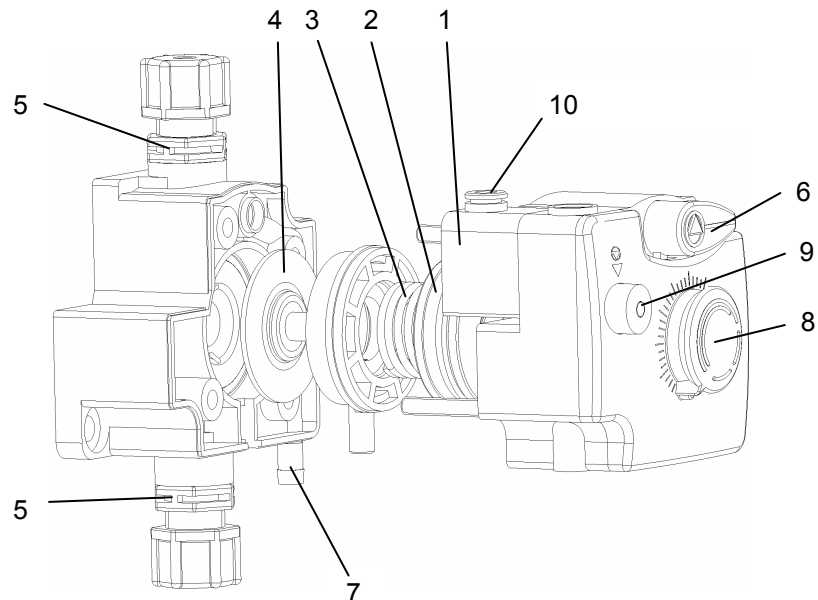

1. Valve block
2. Piston
3. Return spring
4. Diaphragm
5. Double ball valve
6. Venting lever
7. Return line connection
8. Stroke adjustment
9. Manual push button
10. Compressed air inlet

## 2.2 Pump model with integrated solenoid valve

This version of the metering pump is activated via an integrated 3/2-way solenoid control valve (11) (it functions as described at 2.1 above). The compressed air inlet (12) is located at the control block.

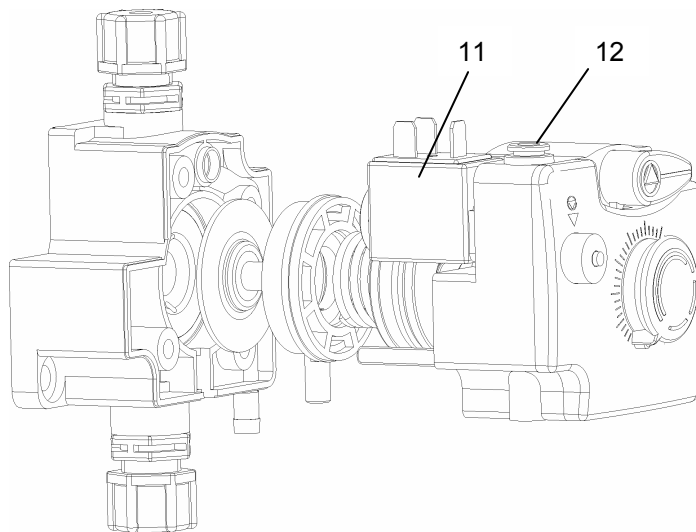

- 11. Solenoid control valve
- 12. Compressed air inlet

## 3. Getting started

**NOTE:** When setting up the pump, take into account the suction height of up to 1.5 metres.

### 3.1. Fixing in place (see also chapter 5)

#### 3.1.1. Fixing to a wall, with screws

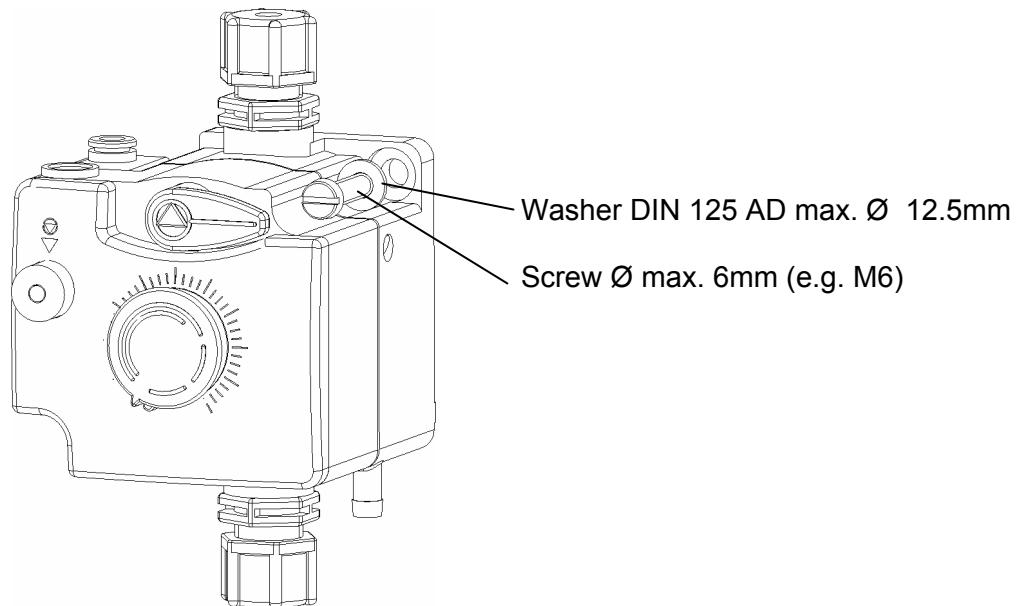

#### 3.1.2. Fixing to a wall, with bayonet-mounting (option)

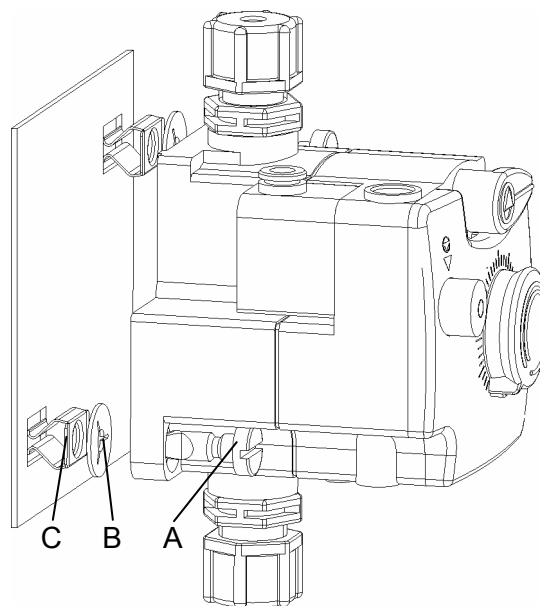

To mount, guide bayonet screw (A) through the hole and then secure by means of retaining washer (B).

The bottom part of the locking unit (C) should be clipped into the square hole.

To lock in place, apply gentle pressure and turn the bayonet screw one quarter of a turn to the left or right.

To release, turn one quarter of a turn to the left or right.

### 3.1.3. Bracket (option)

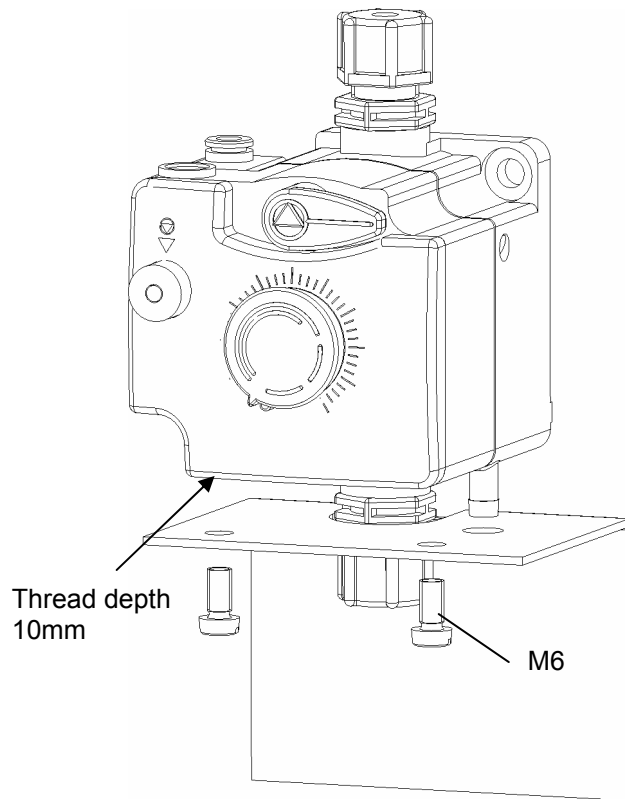

**Warning:** Do not screw into the pump more than 10mm and less than 5mm.

## 3.2 Connections

### 3.2.1 Serto system DI/DA 4/6

- Cut off hose at right angles.
- Slide union nut (1) and clamping ring (2) over the hose.
- Push hose onto the valve's connector nipple right up to the stop collar.
- Tighten union nut
- Push on venting line NW6 (3) and secure from slipping off with hose clip.

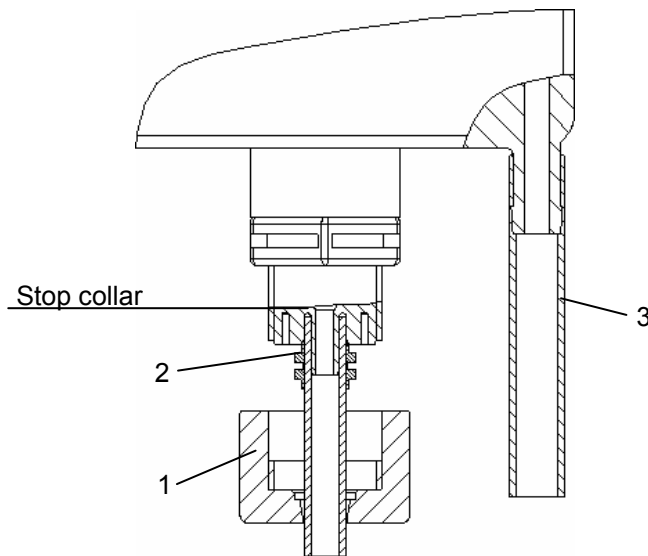

### 3.2.2 Universal system DI/DA 4/6 / 6/8 / 6/12

- Cut off hose at right angles.
- Slide union nut (1) and clamping ring (2) over the hose.
- Push hose onto the tapered part (3) right up to the stop collar.
- Place O-ring (4) into valve groove and tighten union nut.
- Push on venting line NW6 (3) and secure from slipping off with hose clip.

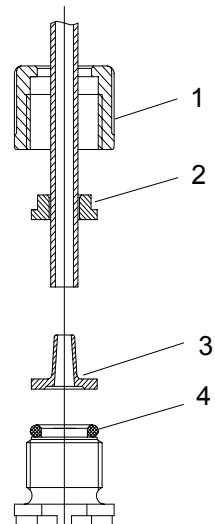

### 3.3 Air connection

Establish air (PE/PA air pressure hose AD6) and electrical connections as appropriate for each model type.

- a) without integrated solenoid valve (see section 2.1)
- b) with integrated solenoid valve (see section 2.2)

### 3.4 Deairing of the pump head

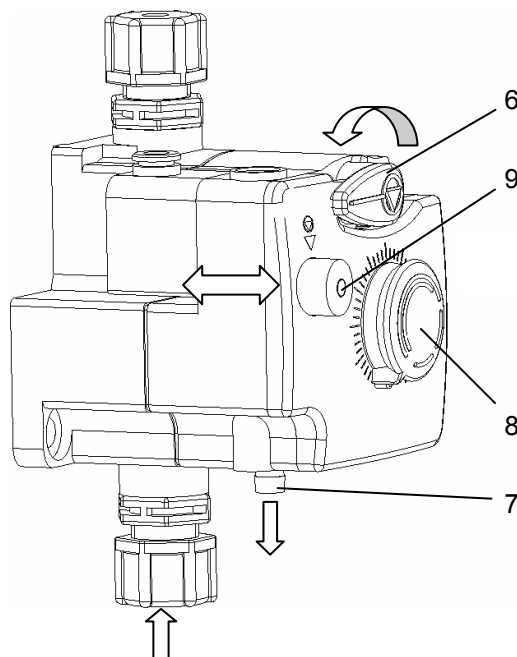

- Turn venting lever (6) to the left to 'Vent', so that the arrow is pointing down
- Using the stroke adjuster, set metering amount to 100% (chapter 3.5)
- Charge the system (air pressure line) with compressed air
  - a) Pump without integrated solenoid valve:
    - Press the push button (9) repeatedly until the metering material comes out of the return line (venting line - 7) without any bubbles. The pump creates suction every time that the button (9) is pushed, and an intake stroke is created every time it's released.
    - Air can also be vented by switching the compressed air on and off.
  - b) Pump with integrated solenoid valve:
    - Air can be vented by activating the solenoid valve or by pressing the manual push button. Each control pulse of the valve or press on the button creates a metering stroke.
    - Repeatedly activate the solenoid valve, or press the push button until the metering material comes out of the return line (venting line) without any bubbles.
- If necessary, set the metering amount, by adjusting the stroke setting after the pump has been primed to the metering amount set prior to venting – see chapter 3.5.
- Turn venting lever to the right to 'Metering', so that the arrow is pointing up.



### 3.5 Stroke setting

To set the metering amount, release the ratchet by pulling out the stroke adjuster (8), set to the desired setting (by turning) and press the stroke adjuster back in.

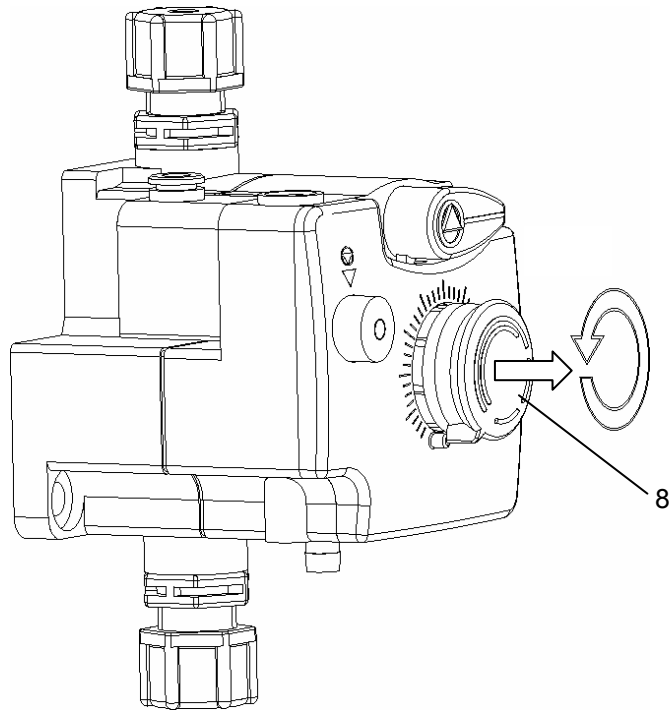

## 4 Technical data

Type	PDP 00030	PDP 00120
Output (l/h)	3.3 / 5 bar	12 / 5 bar
Metering back-pressure (bar)	10	6
Metering operating range, with compressed air at 6 bar.	1.5 - 10	1.5 - 6
Max. air control pressure (bar)	7	
Stroke frequency (strokes/min)	120	
Min. activation time	480 msec. ON 480 msec. OFF	
Suction height (m) at 100% stroke setting*	1.5	
Suction / pressure connection ID / AD	4/6 / option 4/6 / 6/8 / 6/12	
Air connection AD	6	
Voltage** according to version	24 VDC / 50/60 Hz 24 VAC / 50/60 Hz 48 VAC / 50/60 Hz	
Output**	7 W	
Starting time**	100 %	
<b>Component materials:</b>		
Valves, pump head	PP	
Seals	VITON B	
Valve ball	Stainless steel	
Valve spring	Hastelloy	
Housing	PPO / PP	

\* Suction heights with clean, moistened valves

\*\* Figures for pump fitted with solenoid valve

All figures based on water at 20°C and operation in accordance with the operating instructions on

## 5 Dimensions

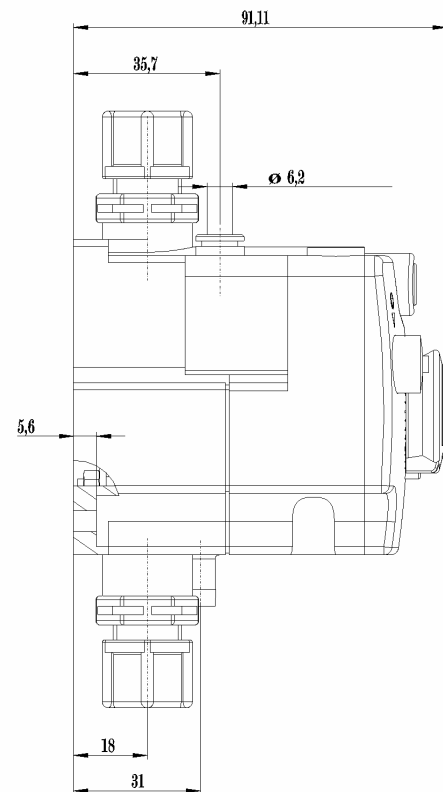
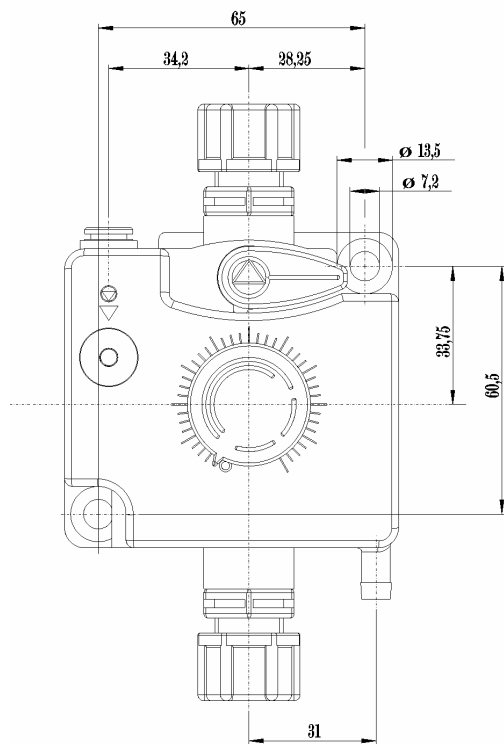
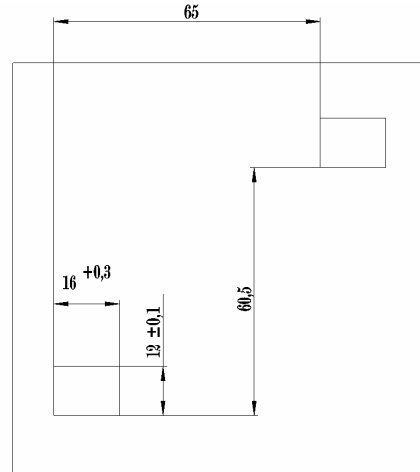
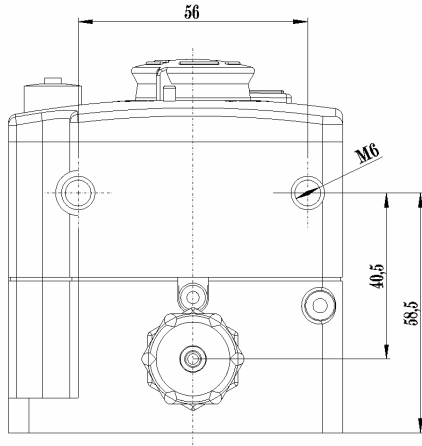

## 6 Metering capacity

To achieve accurate metering, the following points should be noted:

- a) All metering capacity figures are based on measurements with water at 20°C. The metering capacity depends also on the viscosity and the specific gravity of the metering product.
- b) To achieve a high degree of free flow metering accuracy, a pressure maintenance valve (or metering valve) should be used to produce counter pressure of at least 1 bar and to hold it as static as possible.
- c) If there is primary pressure on the suction side, the differential pressure between the suction side and the pressure side should be at least 1 bar. The head of water on the metering pump must be safeguarded by an appropriate valve arrangement.

**NOTE:**            **Neither a pressure maintenance valve nor a metering valve can be regarded as a means of closing off the flow completely.**

**WARNING:**      **Only adjust the metering stroke of a pump that is in use if the stroke adjustment screw is not under pressure.**

## 7 Delivery performance diagrams

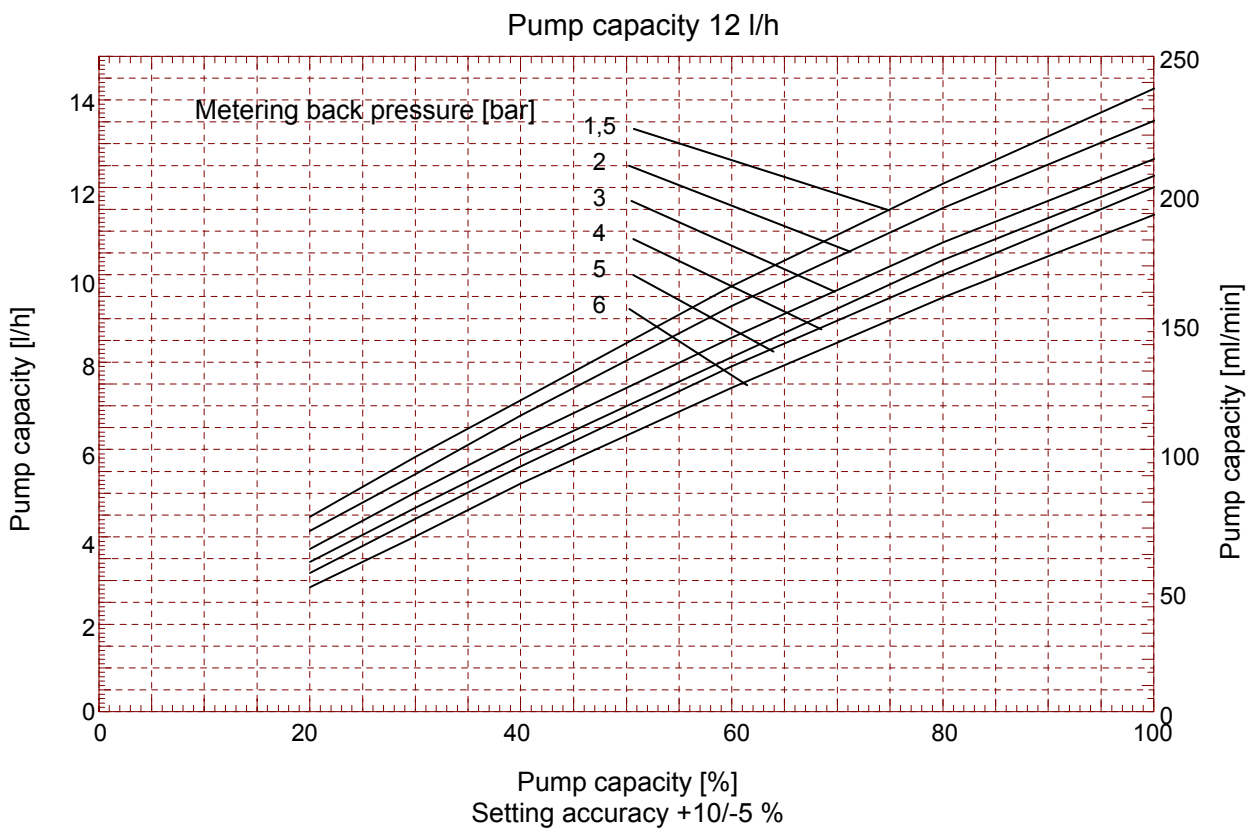
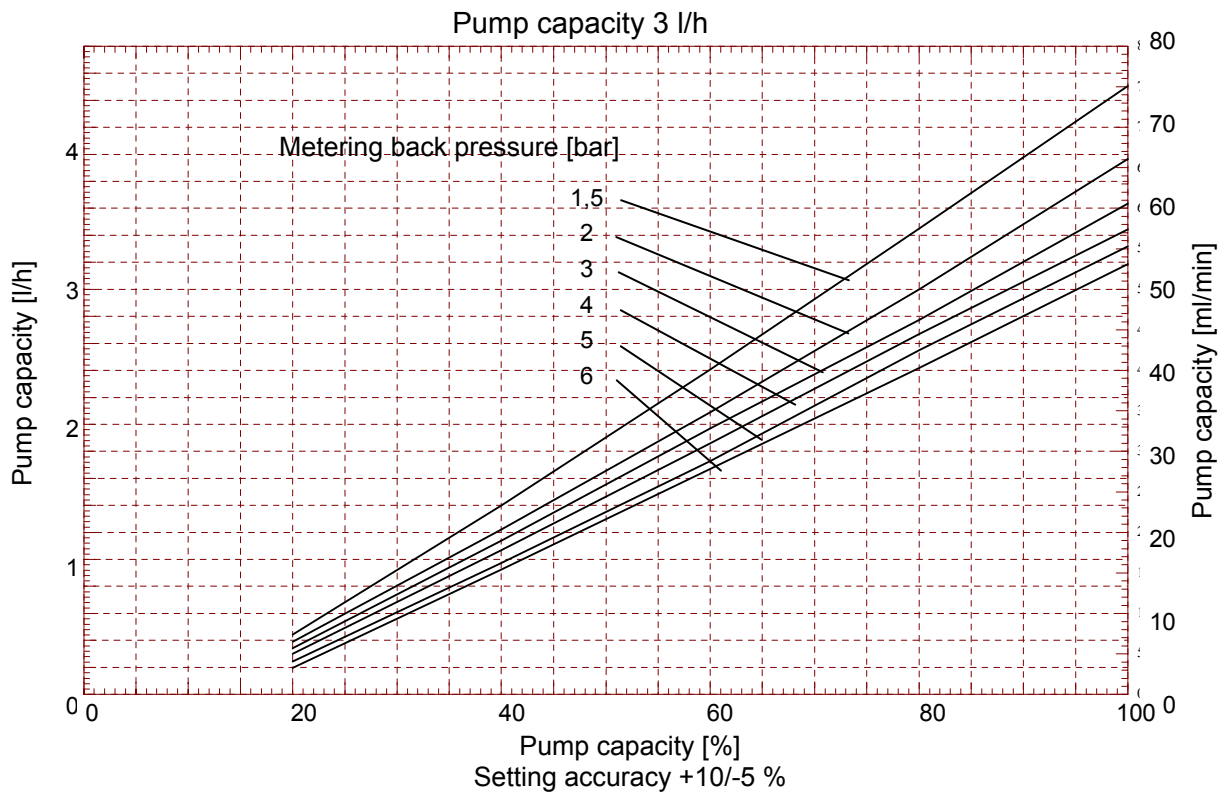

## 8 Maintenance

**CAUTION:** Metering pumps may only be maintained by expert, authorised personnel.

### 8.1 General maintenance

**NOTE:** Quarterly maintenance interval, shorter intervals if load is greater (e.g. constant running).

It is recommended that the following be checked:

- Suction and pressure line for leak-free connection
- Suction and pressure valve (pos. 5) for soiling and sealing function
- Check exit hole on intermediate pump section (membrane break)
- Check correct pumping by suction drive
- Metering head screws

**NOTE:** The lifetime of the membrane depends on:  
Counterpressure, operating temperature and metering material.  
Frequent checking of the membrane is recommended at extreme temperatures and when metering abrasive materials.

### 8.2 Replacement of wearing parts

Diaphragm exchange yearly or after 4000 operating hours (see chapter 9)

Valves exchange yearly

Grease piston lip seal after 3 years.

## 9 Replacing the diaphragm and pump head

**WARNING:** Before any work is done on the valves or the metering head, the metering head must be emptied. Attention should be paid to instructions on the product datasheet for the material being metered.

**NOTE:** Check metering head screw tightening torque after 24 hours. Tightening torque 3 - 4 Nm.

**Changing the diaphragm:** Turn venting lever left. Cross loosen nuts. Pull off pump head. Take out diaphragm cartridge. Clean mounting surfaces in the pump head and piston running surfaces (see arrows). Carefully insert new diaphragm cartridge. Do not damage piston groove ring. The diaphragm cartridge's return flow connector must point downwards. Push the pump head into place and cross tighten with nuts (tightening torque 3-4 Nm). **NOTE:** If necessary, replace clamping ring. Close venting lever (turn right with the arrow in the 'up' metering direction).

- Check for leaks and, if necessary, make adjustments (see section 10, 'Readjusting the venting lever')

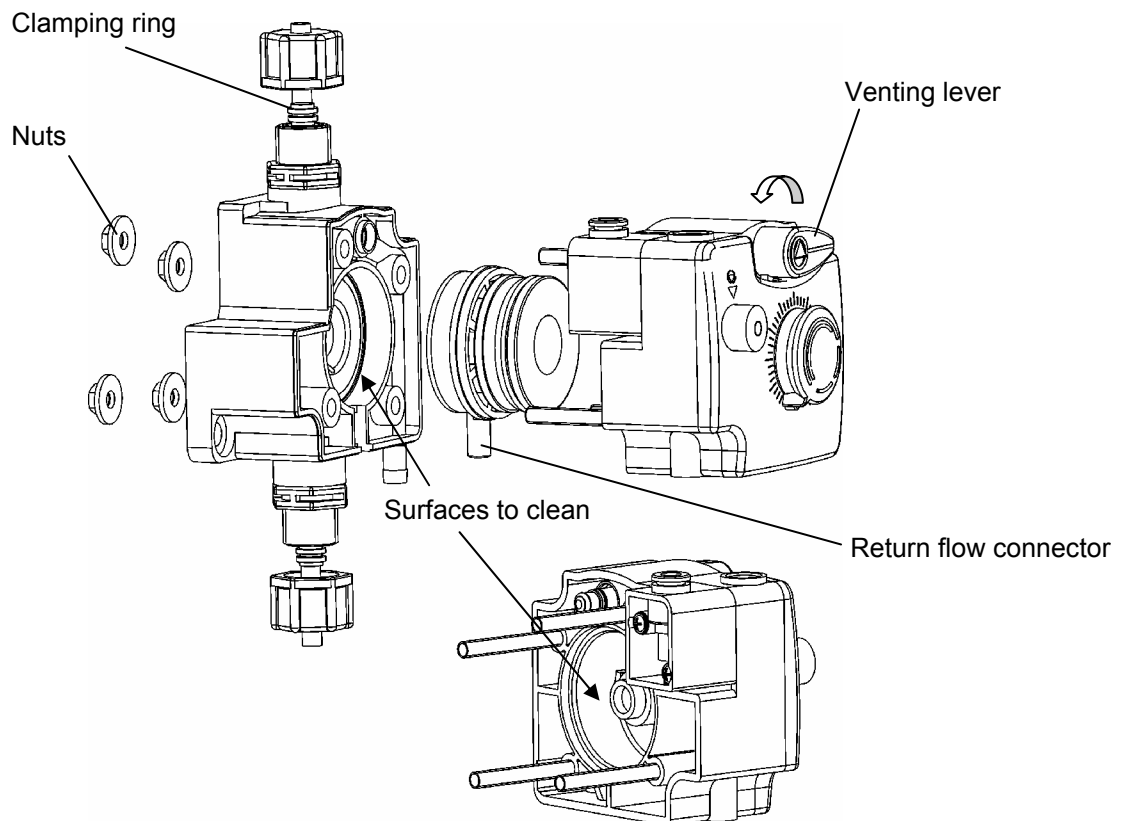

## Changing the pump head:

- Dismantle pump head as described above. Unscrew double ball valve with an open-ended spanner (SW22). Clean diaphragm on mounting surfaces. Fit new pump head and cross tighten with nuts (tightening torque 3-4 Nm). Screw in double ball valve with new O-rings and tighten firmly. NOTE: If necessary, replace clamping ring

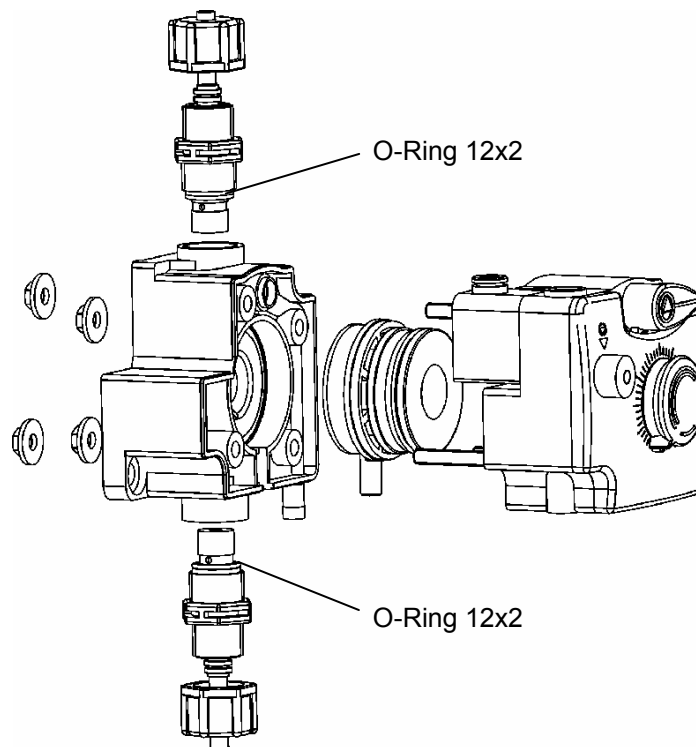



## 10 Readjusting the venting lever

If, despite the venting lever being closed (as in ill. 3), product escapes out of the return line, the venting lever must be readjusted.

To do so, proceed as follows:

- Turn venting lever by 60° left (ill. 1) and pull off.
- Plug in venting lever on left stop position and turn right until there is no metering product escaping from the venting line.
- Pull off venting lever and push it back on 60° position (ill. 1).
- Close venting lever (turn right with the arrow in the 'up' metering direction).
- Check for leaks in venting position (venting lever in left stop position).

If it is impossible to close the venting lever, or only possible with great force, proceed as follows:

- Pull off venting lever as in ill. 2.
- Turned approx. 15° to the right, push it back on.
- Close venting lever (turn right with the arrow in the 'up' metering direction).
- Check for leaks in operating position (ill. 3).

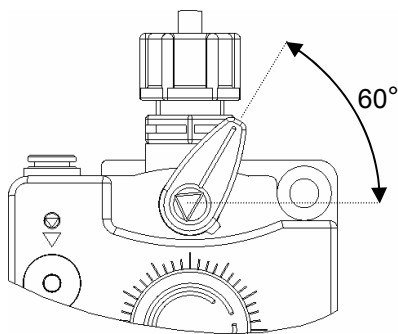

ill. 1

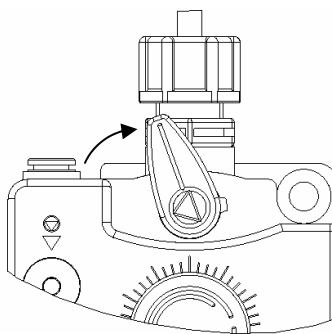

ill. 2

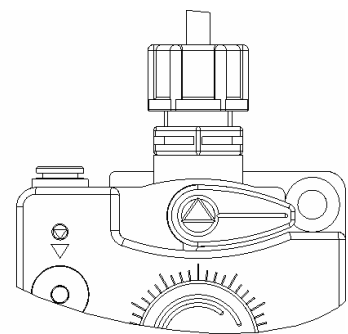

ill. 3

## 11 Tips for dealing with faults which may occur

**CAUTION:** Before carrying out repair and maintenance work or when metering dangerous substances, always rinse the metering head, relieve the pressure line and wear protective clothing (protective glasses, protective gloves and apron).

<b>Fault</b>	<b>Possible cause</b>	<b>Rectification</b>
Pump does not suck up despite bleeding and max. stroke setting	Deposits on the valve seats, valves clogged up or desiccated Return spring broken Air in diaphragm chamber	Flush out suction line and valves. Prime pump head with water Exchange the diaphragm cartridge Deaerate the pump
Pump performance reduced	Air line provides too little pressure Piston seal defective	Check air line and air pressure Exchange the diaphragm cartridge
Pump draws air	Suction and pressure valve connections leak, pump head not tightened down	Check valves and suction line for leaks; tighten pump head screws
Pump head leaks	Pump head is loose, diaphragm ruptured	Tighten pump head screws; exchange the diaphragm
For pump fitted with solenoid valve:		
Pump does not work, even though compressed air supply is OK	No activation signal Defective coil	Check voltage on the solenoid valve If necessary, change coil

## 12 Wearing and replacement parts

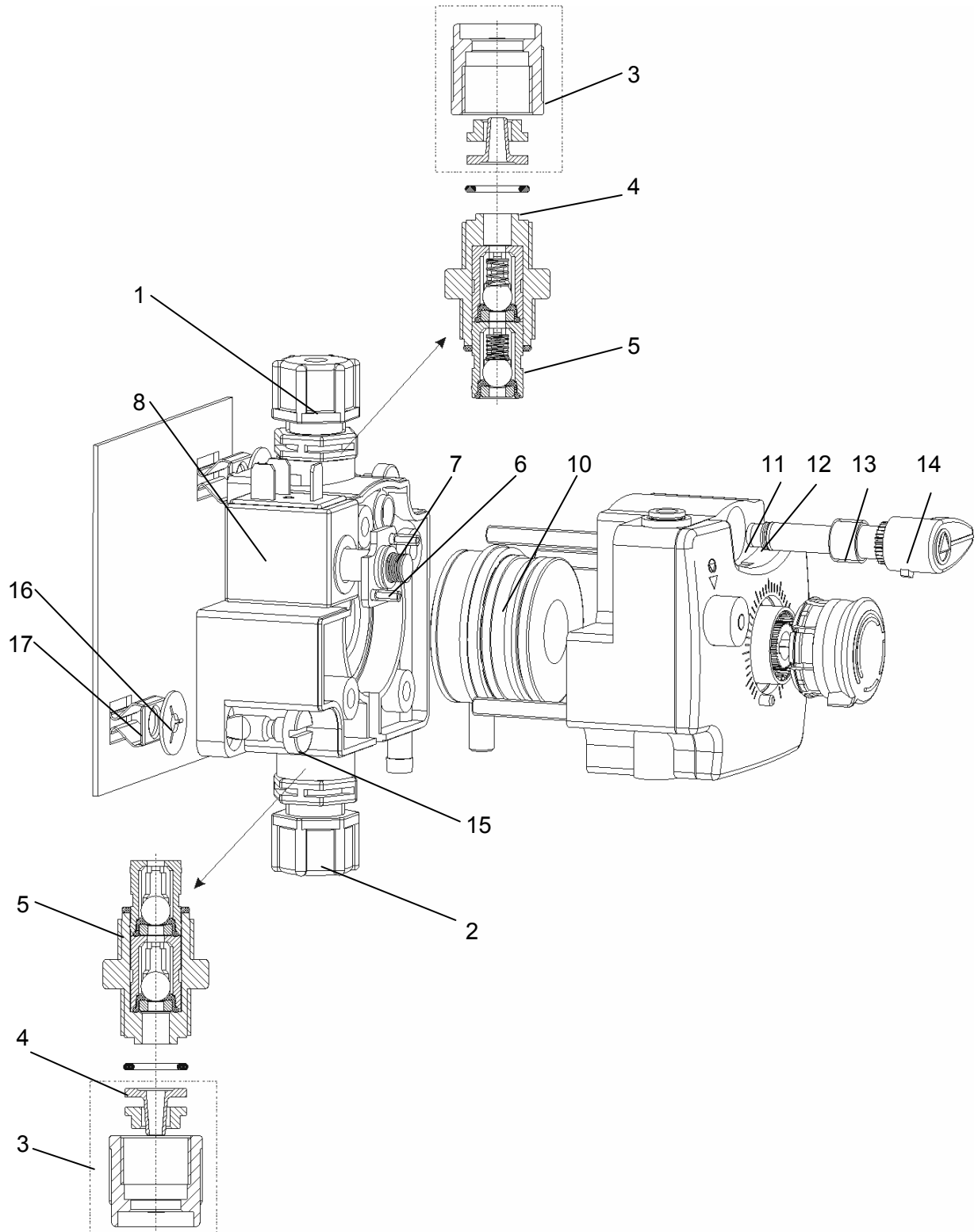

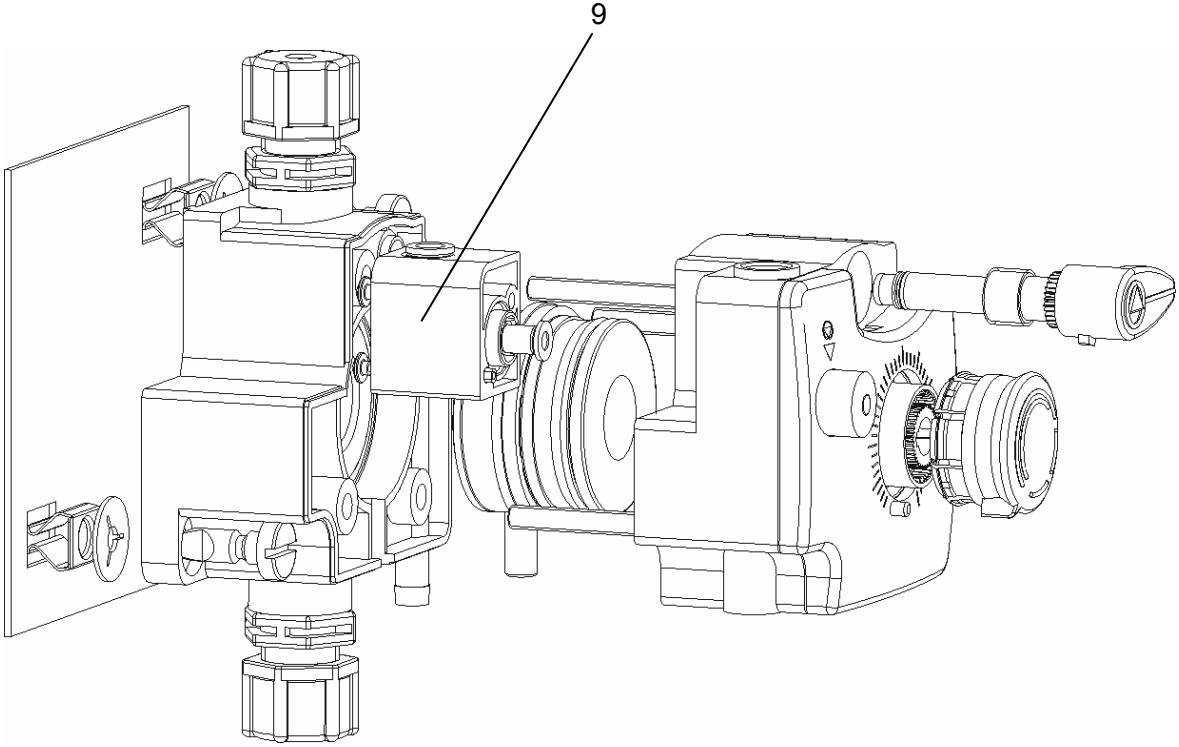

<b>Pos.- no.</b>	<b>Article</b>	<b>Material No.</b>
1	Pressure valve (O-ring Viton B)	241005
	Pressure valve (EPDM)	241007
2	Suction valve (O-ring Viton B)	241004
	Suction valve (EPDM)	241006
3	Connection set (ID/AD) 4/6, 6/8, 6/12 mm	248028
4	O-ring Viton B 10x2,5	417003327
	O-ring EPDM 10x2,5	417001080
5	O-ring Viton B 12x2	417003309
	O-ring EPDM 12x2	417001101
6	Armature system 1,7 CU F FL KPL to be ordered with 2x Pos. 7 (EJOT-PT-screw)	417704075
7	EJOT-PT-screw KB 30 X 10 WN1423 V2A	413071239
8	Magnet coil CK024C 24 V AC	417704076
	Magnet coil CK048C 48 V AC	417704077
	Magnet coil CK024D 24 V DC	417704078
	Magnet coil 230 V AC	417704079
9	Compressed-air inlet	241016
10	Diaphragm cartridge 3,0 l/h	241013
	Diaphragm cartridge 12,0 l/h	241015
11	O-ring Viton B 3,5x1,5	417003313
	O-ring EPDM 3,5x1,5	417001012
12	O-ring Viton B 5,28x1,78	417003596
	O-ring EPDM 5,28x1,78	417001030
13	Venting screw PP PDP	34103016
14	Venting lever	34103018
15	Bayonet screw S60	413229080
16	Retaining washer S60	413229081
17	Locking unit S60	413229082

# Requirements for JCC High Speed Configuration

Obtain the following information from your Service Provider

Static Public IP Address  
Subnet Mask  
Default Gateway  
Both DNS servers

Please request the ISP (internet service provider) to set their modem in Full Bridged Mode. The NetGear FVS318v3 router provided by JCC or purchased from a local retailer will perform all of the firewall functions. If this is a PPOE account, please provide us with user name and password.

The ISP provider can email all the information to [shaunc@jcolemanco.com](mailto:shaunc@jcolemanco.com)

JCC Certified Firewall: NetGear FVS318v3

JCC Setup:

LAN IP for NetGear: 10.137.0.1

Subnet Mask: 255.255.0.0

UserName: admin

Password: magpie5842

NetGear Default: 192.168.0.1

Subnet Mask: 255.255.255.0

User Name: admin

Password: password

Configuration of the LAN side of the network should follow:

IP Redlion 1: 10.137.0.15 or 192.168.0.15 and open ports 789, 4000, and 86

IP Redlion 2: 10.137.0.16 or 192.168.0.16 and open ports 788, 4001 and 85

IP Redlion 3: 10.137.0.17 or 192.168.0.17 and open ports 787, 4002 and 80

Subnet Mask: 255.255.0.0

Gateway: 10.137.0.1 or 192.168.0.1

Either configuration is acceptable for compliance with our standards.



# JCC High Speed Configuration

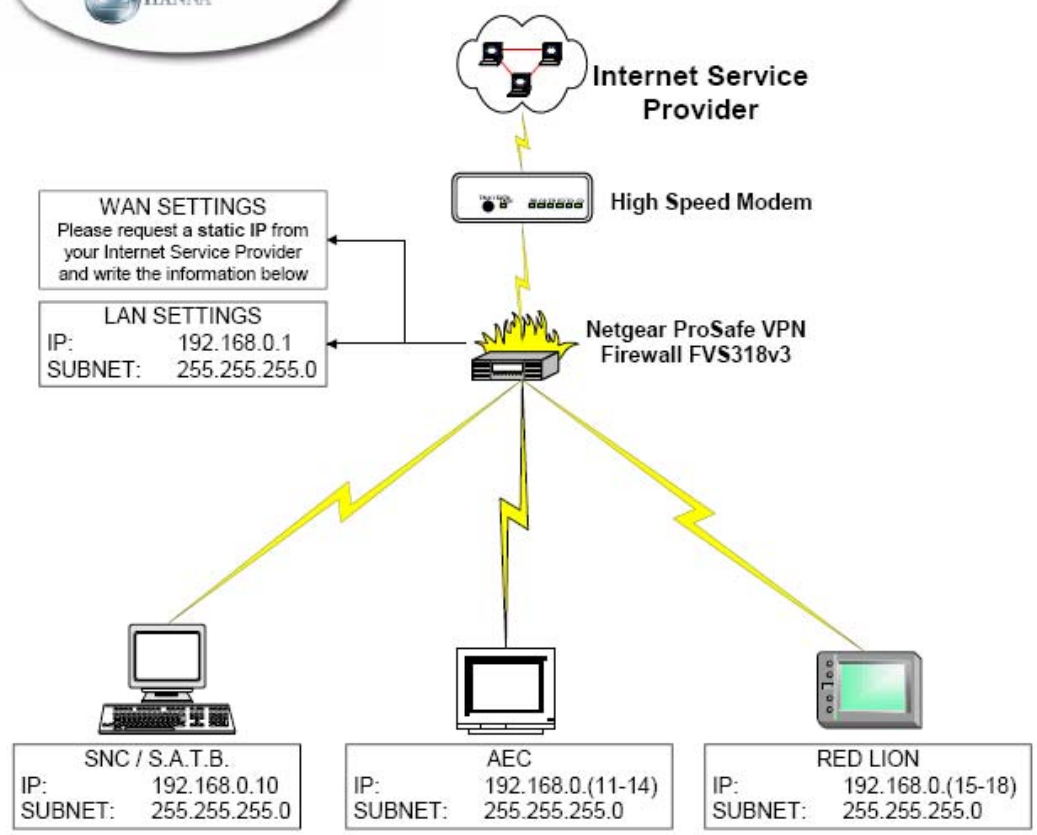

Carwash Name: \_\_\_\_\_

**STATIC IP SETTINGS**  
(from ISP)

IP: \_\_\_\_\_

SUBNET: \_\_\_\_\_

GATEWAY: \_\_\_\_\_

DNS 1: \_\_\_\_\_

DNS 2 (if any): \_\_\_\_\_

DNS 3 (if any): \_\_\_\_\_

Please Contact JCC Technical Support for High Speed Setup

# FusionX Gantry Eye Wiring

**Driver's Side**

**Passenger's Side**

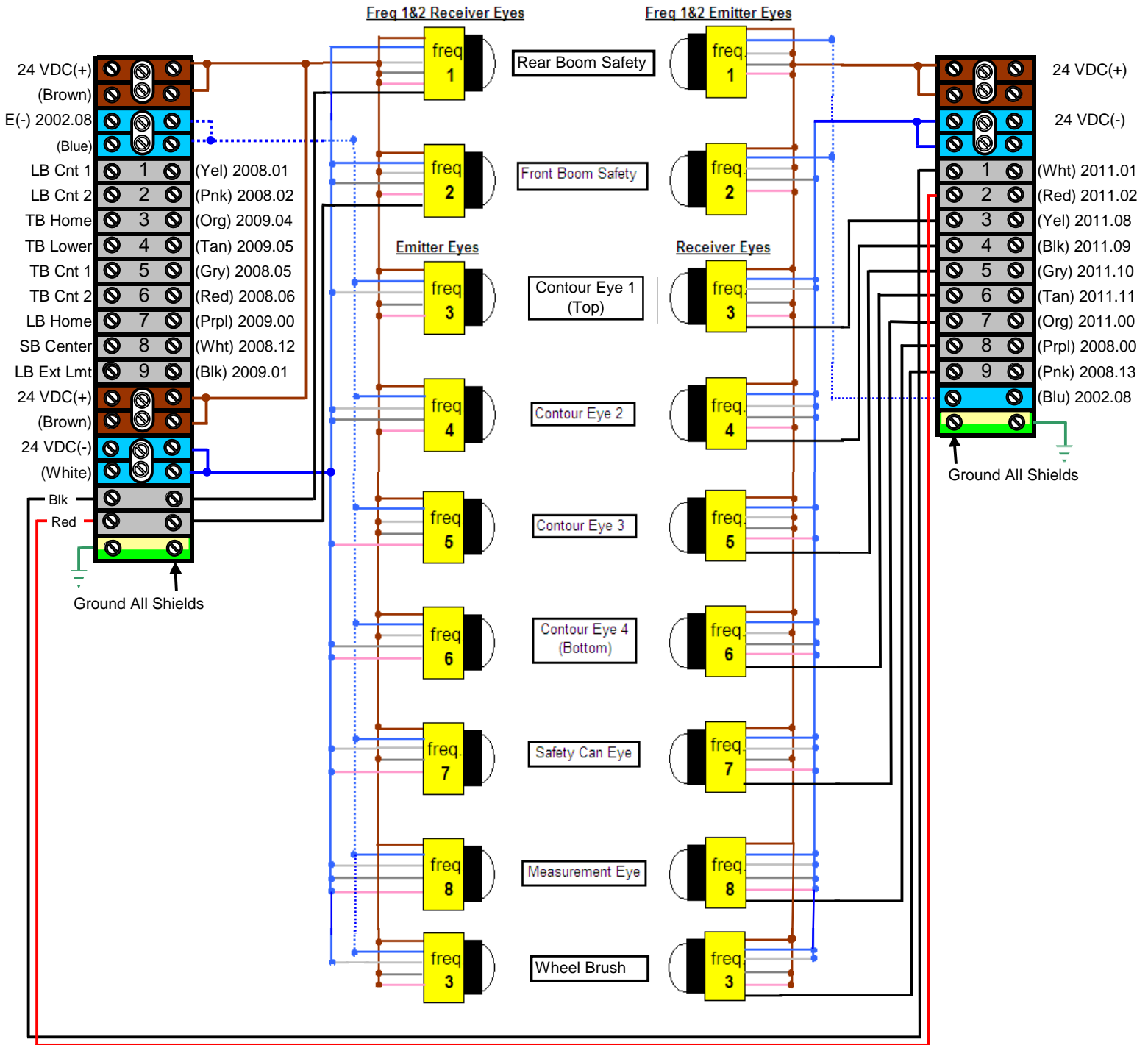

**Eye Wire Color Code**

